

SANTA CRUZ METROPOLITAN TRANSIT DISTRICT

BOARD OF DIRECTORS REGULAR MEETING AGENDA
JANUARY 9, 2009 (Second Friday of Each Month)
SCMTD ENCINAL CONFERENCE ROOM
370 ENCINAL STREET, SUITE 100
SANTA CRUZ, CALIFORNIA
9:00 a.m. – 11:00 a.m.

THE BOARD AGENDA PACKET CAN BE FOUND ONLINE AT WWW.SCMTD.COM

NOTE: THE BOARD CHAIR MAY TAKE ITEMS OUT OF ORDER

SECTION I: OPEN SESSION - 9:00 a.m.

1. a. ROLL CALL
- b. CONSIDERATION OF:
 - 1) **NOMINATION** OF DIRECTORS TO SERVE AS BOARD OFFICERS,
 - 2) **NOMINATIONS** FOR APPOINTMENTS TO THE HIGHWAY 1 CONSTRUCTION AUTHORITY,
 - 3) **NOMINATIONS** FOR APPOINTMENTS TO THE SANTA CRUZ COUNTY REGIONAL TRANSPORTATION COMMISSION FOR 2009Presented by: Leslie R. White, General Manager
2. ORAL AND WRITTEN COMMUNICATION TO THE BOARD OF DIRECTORS
 - a. None
3. LABOR ORGANIZATION COMMUNICATIONS
4. ADDITIONAL DOCUMENTATION TO SUPPORT EXISTING AGENDA ITEMS

CONSENT AGENDA

- 5-1. ACCEPT AND FILE PRELIMINARILY APPROVED CLAIMS FOR THE MONTH OF DECEMBER 2008
- 5-2. ACCEPT AND FILE MONTHLY BUDGET STATUS REPORT FOR NOVEMBER 2008
- 5-3. CONSIDERATION OF TORT CLAIMS: None
- 5-4. ACCEPT AND FILE THE METRO ADVISORY COMMITTEE (MAC) AGENDA FOR JANUARY 21, 2009 AND MINUTES OF NOVEMBER 19, 2008

- 5-5. CONSIDERATION OF AUTHORIZING THE GENERAL MANAGER TO EXECUTE A CONTRACT RENEWAL WITH SC FUELS FOR DELIVERY OF CARB ULTRA LOW SULFUR DIESEL FUEL
- 5-6. CONSIDERATION OF AUTHORIZING THE GENERAL MANAGER TO EXECUTE A CONTRACT WITH FIRST CAPITOL AUCTION, INC. FOR PUBLIC AUCTION SERVICES
- 5-7. CONSIDERATION OF RESOLUTION DESIGNATING ASSISTANT FINANCE MANAGER TO CALTIP BOARD OF DIRECTORS AND MANAGER OF OPERATIONS AS DESIGNATED ALTERNATE
- 5-8. CONSIDERATION OF AUTHORIZING THE GENERAL MANAGER TO EXECUTE A CONTRACT WITH SUE CLARKE FOR CONTINUING TO AUDIT THE TALKING BUSES EXTERNAL ANNOUNCEMENTS AT THE BART CAVALLARO TRANSIT CENTER

REGULAR AGENDA

6. PRESENTATION OF EMPLOYEE LONGEVITY AWARDS: None
7. PUBLIC HEARING: CONSIDERATION OF ADOPTING A PROGRAM OF PROJECTS FOR FY 2009 FEDERAL FUNDING ASSISTANCE AND ADOPTING A RESOLUTION AUTHORIZING THE APPLICATION AND EXECUTION OF GRANTS FOR FY 2009 FUNDS
Presented By: Angela Aitken, Finance Manager
PUBLIC HEARING WILL TAKE PLACE AT THE JANUARY 23, 2009 BOARD MEETING
8. CONSIDERATION OF AUTHORIZING THE GENERAL MANAGER TO EXECUTE A CONTRACT WITH JOS. J. ALBANESE, INC. FOR DEMOLITION OF THE OLD BUS WASH AREA AT 1200 RIVER STREET
Presented By: Angela Aitken, Finance Manager
ACTION REQUESTED AT THE JANUARY 9, 2009 BOARD MEETING
9. REVIEW OF ITEMS TO BE DISCUSSED IN CLOSED SESSION: District Counsel
10. ORAL AND WRITTEN COMMUNICATIONS REGARDING CLOSED SESSION

SECTION II: CLOSED SESSION

1. CONFERENCE WITH REAL PROPERTY NEGOTIATORS
(Pursuant to Government Code Section 54956.8)
 - a. Property: Felton Faire Shopping Center, 6255 Graham Hill Road, Felton, CA

Negotiating Parties: Margaret Gallagher and Leslie R. White for SCMTD
Robert Marin for Robert Marin and Celeste De
Schulthess, Trustees, Property Owners
Under Negotiation: License Agreement Terms

SECTION III: RECONVENE TO OPEN SESSION

11. REPORT OF CLOSED SESSION
12. CONSIDERATION OF AUTHORIZING THE GENERAL MANAGER TO EXECUTE A TWO-YEAR IRREVOCABLE LICENSE AGREEMENT IN FAVOR OF SANTA CRUZ METRO WITH ROBERT MARIN AND CELESTE DE SCHULTHESS, TRUSTEES, FOR PLACEMENT OF A BUS STOP SHELTER ON THE FELTON FAIRE SHOPPING CENTER PROPERTY AND USAGE OF THE BUS STOP
Presented By: Margaret Gallagher, District Counsel
ACTION REQUESTED AT THE JANUARY 9, 2009 BOARD MEETING

ADJOURN

NOTICE TO PUBLIC

Members of the public may address the Board of Directors on a topic not on the agenda but within the jurisdiction of the Board of Directors or on the consent agenda by approaching the Board during consideration of Agenda Item #2 "Oral and Written Communications", under Section I. Presentations will be limited in time in accordance with District Resolution 69-2-1.

When addressing the Board, the individual may, but is not required to, provide his/her name and address in an audible tone for the record.

Members of the public may address the Board of Directors on a topic on the agenda by approaching the Board immediately after presentation of the staff report but before the Board of Directors' deliberation on the topic to be addressed. Presentations will be limited in time in accordance with District Resolution 69-2-1.

The Santa Cruz Metropolitan Transit District does not discriminate on the basis of disability. The Encinal Conference Room is located in an accessible facility. Any person who requires an accommodation or an auxiliary aid or service to participate in the meeting, please contact Cindi Thomas at 831-426-6080 as soon as possible in advance of the Board of Directors meeting. Hearing impaired individuals should call 711 for assistance in contacting METRO regarding special requirements to participate in the Board meeting.

SANTA CRUZ METROPOLITAN TRANSIT DISTRICT

DATE: January 9, 2009

TO: Board of Directors

FROM: Leslie R. White, General Manager

SUBJECT: CONSIDERATION OF:

- 1) **NOMINATION OF DIRECTORS TO SERVE AS BOARD OFFICERS,**
- 2) **NOMINATIONS FOR APPOINTMENTS TO THE HIGHWAY 1 CONSTRUCTION AUTHORITY, AND**
- 3) **NOMINATIONS FOR APPOINTMENTS TO THE SANTA CRUZ COUNTY REGIONAL TRANSPORTATION COMMISSION FOR 2008**

ACTION REQUESTED AT THE JANUARY 9, 2009 BOARD MEETING

I. RECOMMENDED ACTION

That the Board of Directors identify nominees from the Board to be considered for election to the positions of Board Chair, Vice Chair, Representative and Alternate to the Highway 1 Construction Authority, Representatives and Alternates for the Santa Cruz County Regional Transportation Commission for 2009.

II. SUMMARY OF ISSUES

- Article 6 of the METRO Bylaws provides that the Board of Directors shall annually nominate members to be considered for election to the positions of Chair and Vice Chair.
- It is necessary for the Board of Directors to nominate members to be considered for election to represent METRO on the Board of Directors of the Highway 1 Construction Authority (HCA).
- In order to maintain representation on the Santa Cruz County Regional Transportation Commission (SCCRTC) it is necessary that the Board of Directors nominate members to be considered for election to the three positions and three alternate positions that are provided for METRO.
- Currently elections for the positions referenced in this Staff Report are scheduled to be held at the January 23, 2009 Board of Directors meeting.

III. DISCUSSION

The terms of the officers and appointees of the Board of Directors in the positions of Chair, Vice Chair, HCA appointees, and SCCRTC appointees expire in January 2009. The METRO Bylaws provide that the Board of Directors shall identify nominees to be considered for election to the positions herein referenced.

1-b.1

Staff recommends that the Board of Directors identify members to be nominees for the positions of Chair, Vice Chair, HCA appointee and alternate, and SCCRTC appointees and alternates. The election of nominees to the referenced positions is scheduled to be held January 23, 2009.

IV. FINANCIAL CONSIDERATIONS

Funding support for the positions identified in this Staff Report is contained in the adopted METRO FY 2009 Operating Budget.

V. ATTACHMENTS

None

SANTA CRUZ METROPOLITAN TRANSIT DISTRICT
 CHECK JOURNAL DETAIL BY CHECK NUMBER
 ALL CHECKS FOR ACCOUNTS PAYABLE

DATE: 12/01/08 THRU 12/31/08

CHECK NUMBER	CHECK DATE	CHECK AMOUNT	VENDOR	VENDOR NAME	VENDOR TRANS. TYPE	TRANS. NUMBER	TRANSACTION DESCRIPTION	TRANSACTION AMOUNT	COMMENT
31078	12/18/08	-70.00	682	WEISS, AMY L.	7	23397	OCT INTERPRETER	-70.00	**VOID
31222	12/05/08	100.00	002069	A TOOL SHED, INC.		24149	OCT EQUIP RENTAL	100.00	
31223	12/05/08	237.87	001193	AA GLASS SHOP	7	24072	SERVICE/WTC	237.87	
31224	12/05/08	1,569.96	002509	ACCOMTEMP		23936	TEMP/OPS W/E 11/7	1,569.96	
31225	12/05/08	1,084.51	020	ADT SECURITY SERVICES INC.		24052	SERVICE/1200 B RIVER	160.09	
						24053	INSTALL/ 1200 RIVER	924.42	
31226	12/05/08	134.01	E636	AGUIRRE, CIRO		24166	10/4-10/8 EMP TRAVEL	134.01	
31227	12/05/08	658.42	E437	AITKEN, ANGELA		24086	08 HOLIDAY PARTY	350.00	
						24167	10/4-10/9 EMP TRAVEL	308.42	
31228	12/05/08	600.00	R538	ALLEN, WESLEY		24085	SETTLEMENT/RISK	600.00	
31229	12/05/08	186.49	002861	AMERICAN MESSAGING SVCS, LLC		24144	DEC PAGERS	186.49	
31230	12/05/08	49.11	294	ANDY'S AUTO SUPPLY	0	23996	OFFICE SUPPLIES/FLT	43.14	
						23997	OFFICE SUPPLIES	5.97	
31231	12/05/08	18,828.08	941	ASSURANT EMPLOYEE BENEFITS		24047	DEC LTD INS	18,828.08	
31232	12/05/08	1,289.11	001	AT&T		24151	OCT PHONES/138 GOLF	788.59	
						24152	OCT PHONES/138 GOLF	500.52	
31233	12/05/08	404.32	664	BAY COUNTIES PITCOCK PETROLEUM		23967	FUEL & LUBE	404.32	
31234	12/05/08	17.65	123	BAY PHOTO LAB		23868	PHOTO PROCESS/PT	7.73	
						23869	PHOTO PROCESS/PT	9.92	
31235	12/05/08	100.00	B003	BEAUTZ, JAN	7	24153	NOV BOARD MTGS	100.00	
31236	12/05/08	774.00	011	BEWLEYS CLEANING	7	24017	NOV JANITORIAL/PT	774.00	
31237	12/05/08	100.00	B018	BUSTICHI, DENE	7	24154	NOV BOARD MTGS	100.00	
31238	12/05/08	441,030.12	502	CA PUBLIC EMPLOYEES'		23963	DEC MEDICAL INS	441,030.12	
31239	12/05/08	195.00	002034	CARLON'S FIRE EXTINGUISHER		23926	PERMIT / EL DANDY	195.00	
31240	12/05/08	272.85	002627	CDW GOVERNMENT, INC.		23979	OFFICE SUPPLY/IT	272.85	
31241	12/05/08	106.34	002898	CEB		23805	CA MECH LIENS UPDATE	106.34	
31242	12/05/08	61.38	172	CENTRAL WELDER'S SUPPLY, INC.		23990	PARTS & SUPPLIES	61.38	
31243	12/05/08	672.00	002109	CITY OF SANTA CRUZ/PARKING		23970	7 PARKING PERMITS	672.00	
31244	12/05/08	50.70	667	CITY OF SCOTTS VALLEY		24022	9/15-11/15 KINGS VLG	50.70	
31245	12/05/08	2,100.58	130	CITY OF WATSONVILLE UTILITIES		24024	9/4-11/4 RODRIGUEZ	501.96	
						24040	CONTAINER/RODRIGUEZ	1,443.56	
						24041	9/4-11/4 RODRIGUEZ	87.66	
						24042	9/4-11/4 RODRIGUEZ	67.40	
31246	12/05/08	100.00	B014	CITY OF WATSONVILLE		24162	NOV BOARD MTGS	100.00	
31247	12/05/08	500.00	001113	CLARKE, SUSAN	7	23943	EXT BUS ANNOUNC/AUD	500.00	
31248	12/05/08	9,293.98	909	CLASSIC GRAPHICS		23747	OUT RPR #9829	4,602.04	
						24001	OUT RPR # 9807	4,691.94	
31249	12/05/08	59,306.30	001124	CLEAN ENERGY		23933	NOV LNG/FLT	16,842.67	
						24073	11/18-11/21 LNG/FLT	18,129.80	
						24074	11/9-11/15 LNG/FLT	24,333.83	
31250	12/05/08	175.77	075	COAST PAPER & SUPPLY INC.		23962	PARTS & SUPPLIES	175.77	
31251	12/05/08	67,032.08	002569	COMERICA BANK		24173	WORK COMP FUND	67,032.08	
31252	12/05/08	84.27	002063	COSTCO		23937	PHOTO PROCESS/OPS	2.53	
						23938	PHOTO PROCESS/OPS	6.36	
						23939	PHOTO PROCESS/OPS	4.67	
						23940	PHOTO PROCESS/OPS	5.05	
						23941	OFFICE SUPPLY/OPS	49.44	
						23946	LOCAL MTG EXP	16.22	
31253	12/05/08	10.95	418	COUNTY OF SANTA CRUZ		23932	OCT CNG	10.95	
31254	12/05/08	773.57	504	CUMMINS WEST, INC.		24032	REV VEH PARTS	70.03	

5-1.1

SANTA CRUZ METROPOLITAN TRANSIT DISTRICT
 CHECK JOURNAL DETAIL BY CHECK NUMBER
 ALL CHECKS FOR ACCOUNTS PAYABLE

DATE: 12/01/08 THRU 12/31/08

CHECK NUMBER	CHECK DATE	CHECK AMOUNT	VENDOR	VENDOR NAME	VENDOR TYPE	TRANS. NUMBER	TRANSACTION DESCRIPTION	TRANSACTION AMOUNT	COMMENT
						24033	REV VEH PARTS	83.96	
						24034	CREDIT NOTE	-83.96	
						24050	REV VEH PARTS	80.53	
						24051	REV VEH PARTS	286.41	
						24132	REV VEH PARTS	22.72	
						24141	REV VEH PARTS	313.88	
31255	12/05/08	41,445.02	800	DELTA DENTAL PLAN		23974	DEC DENTAL	41,445.02	
31257	12/05/08	1,070.00	916	DOCTORS ON DUTY		24090	DRUG TEST	30.00	
						24091	DRUG TEST	35.00	
						24092	DRUG TEST	5.00	
						24093	DRUG TEST	30.00	
						24094	DRUG TEST	5.00	
						24095	DRUG TEST	30.00	
						24096	DRUG TEST	35.00	
						24097	DRUG TEST	5.00	
						24098	DRUG TEST	30.00	
						24099	DRUG TEST	5.00	
						24100	DRUG TEST	30.00	
						24101	DRUG TEST	5.00	
						24102	DRUG TEST	30.00	
						24103	DRUG TEST	5.00	
						24104	DRUG TEST	30.00	
						24105	DRUG TEST	5.00	
						24106	DRUG TEST	30.00	
						24107	DRUG TEST	5.00	
						24108	DRUG TEST	30.00	
						24109	DRUG TEST	5.00	
						24110	DRUG TEST	30.00	
						24111	DRUG TEST	5.00	
						24112	DRUG TEST	30.00	
						24113	DRUG TEST	5.00	
						24114	DRUG TEST	30.00	
						24115	DRUG TEST	5.00	
						24116	DRUG TEST	30.00	
						24117	DRUG TEST	35.00	
						24118	DRUG TEST	5.00	
						24119	DRUG TEST	120.00	
						24120	DRUG TEST	5.00	
						24121	DRUG TEST	30.00	
						24122	DRUG TEST	5.00	
						24123	DRUG TEST	30.00	
						24124	DRUG TEST	5.00	
						24125	DRUG TEST	120.00	
						24126	DRUG TEST	5.00	
						24127	DRUG TEST	120.00	
						24128	DRUG TEST	30.00	
						24129	DRUG TEST	35.00	
						24130	DRUG TEST	5.00	
31258	12/05/08	300.00	001148	DOMHOFF, JOEL		24175	08 HOLIDAY PARTY DJ	300.00	
31259	12/05/08	73.25	298	ERGOMETRICS		23975	SCORING SERVICES	73.25	

5-1.2

SANTA CRUZ METROPOLITAN TRANSIT DISTRICT
 CHECK JOURNAL DETAIL BY CHECK NUMBER
 ALL CHECKS FOR ACCOUNTS PAYABLE

DATE: 12/01/08 THRU 12/31/08

CHECK NUMBER	CHECK DATE	CHECK AMOUNT	VENDOR	VENDOR NAME	VENDOR TYPE	TRANS. NUMBER	TRANSACTION DESCRIPTION	TRANSACTION AMOUNT	COMMENT
31260	12/05/08	1,692.25	001492	EVERGREEN OIL INC.		24079	HAZ WASTE DISP	1,461.00	
						24080	HAZ WASTE DISP	106.25	
						24081	HAZ WASTE DISP	125.00	
31261	12/05/08	60.01	372	FEDERAL EXPRESS		23965	OCT-NOV MAIL	60.01	
31262	12/05/08	56.23	E323	GALE, TERRY		24165	10/6-10/8 EMP TRAVEL	56.23	
31263	12/05/08	1,478.32	117	GILLIG LLC		23818	REV VEH PARTS	963.70	
						24054	REV VEH PARTS	448.50	
						24055	REV VEH PARTS	66.12	
31264	12/05/08	379.83	001039	GRAFFITI REMOVAL, INC.		24057	REV VEH PARTS	379.83	
31265	12/05/08	605.22	282	GRAINGER		24056	REV VEH PARTS	294.91	
						24078	REPAIRS/MAINTENANCE	78.12	
						24133	PARTS & SUPPLIES	44.43	
						24142	REPAIRS/MAINTENANCE	187.76	
31266	12/05/08	93.43	546	GRANITEROCK COMPANY		24076	REPAIRS/MAINTENANCE	53.39	
						24077	REPAIRS/MAINTENANCE	40.04	
31267	12/05/08	100.00	B021	HAGEN, DONALD N.	7	24155	NOV BOARD MTGS	100.00	
31268	12/05/08	3,766.79	001745	HARTFORD LIFE AND ACCIDENT INS		23964	DEC LIFE/AD&D INS	3,766.79	
31269	12/05/08	50.00	B006	HINKLE, MICHELLE	7	24156	NOV BOARD MTGS	50.00	
31270	12/05/08	1,185.00	575	JAQUA OF CALIFORNIA		24075	REPAIRS/MAINTENANCE	1,185.00	
31271	12/05/08	2,076.00	878	KELLY SERVICES, INC.		24020	TEMP/FLT W/E 11/09	504.00	
						24021	TEMP/FLT W/E 11/16	744.00	
						24150	TEMP/FLT W/E 11/23	828.00	
31272	12/05/08	37.48	036	KELLY-MOORE PAINT CO., INC.		24015	REPAIRS/MAINTENANCE	37.48	
31273	12/05/08	37.43	074	KENVILLE LOCKSMITHS	7	23809	REPAIRS/MAINTENANCE	9.98	
						24012	REPAIRS/MAINTENANCE	12.48	
						24013	REPAIRS/MAINTENANCE	14.97	
31274	12/05/08	3,417.34	001233	KIMBALL MIDWEST		23846	PARTS & SUPPLIES	71.03	
						23847	REV VEH PARTS	298.80	
						23953	PARTS & SUPPLIES	2,874.00	
						24058	PARTS & SUPPLIES	173.51	
31275	12/05/08	366.55	039	KINKO'S INC.		23934	PRINTING/OPS	264.27	
						23935	PRINTING/OPS	102.28	
31276	12/05/08	198.00	E635	KINSLOW, DEBBIE		23972	11/24 EMP TRAVEL	198.00	
31277	12/05/08	495.00	852	LAW OFFICES OF MARIE F. SANG	7	24087	WORKERS COMP CLAIM	345.00	
						24088	WORKERS COMP CLAIM	150.00	
31278	12/05/08	34.72	040	LENZ ARTS, INC.		24016	REPAIRS/MAINTENANCE	34.72	
31279	12/05/08	834.60	001145	MANAGED HEALTH NETWORK		24049	DEC EAP PREMIUM	834.60	
31280	12/05/08	44.00	E518	MARCUS, STEVEN		23945	DMV FEES	44.00	
31281	12/05/08	44.00	E510	MENDOZA, URIEL		23944	DMV FEES	44.00	
31282	12/05/08	1,797.42	001052	MID VALLEY SUPPLY		23814	CLEANING SUPPLIES	583.73	
						23820	CLEANING SUPPLIES	349.59	
						23821	CLEANING SUPPLIES	275.33	
						24018	CLEANING SUPPLIES	193.84	
						24019	CLEANING SUPPLIES	394.93	
31283	12/05/08	933.81	041	MISSION UNIFORM		23749	UNIF/LAUNDRY/FAC	65.30	
						23778	UNIF/LAUNDRY/FLT	50.60	
						23779	UNIF/LAUNDRY/FLT	127.26	
						23780	UNIF/LAUNDRY/FLT	43.26	
						23781	UNIF/LAUNDRY/FLT	273.68	
						23930	UNIF/LAUNDRY/FAC	69.60	

5-1.3

SANTA CRUZ METROPOLITAN TRANSIT DISTRICT
 CHECK JOURNAL DETAIL BY CHECK NUMBER
 ALL CHECKS FOR ACCOUNTS PAYABLE

DATE: 12/01/08 THRU 12/31/08

CHECK NUMBER	CHECK DATE	CHECK AMOUNT	VENDOR	VENDOR NAME	VENDOR TYPE	TRANS. NUMBER	TRANSACTION DESCRIPTION	TRANSACTION AMOUNT	COMMENT
						23947	UNIF/LAUNDRY/FLT	24.46	
						23948	UNIF/LAUNDRY/FLT	44.29	
						23949	UNIF/LAUNDRY/FLT	43.26	
						23950	UNIF/LAUNDRY/FLT	192.10	
31284	12/05/08	45,717.82	001225	NATIONAL SECURITY SERVICE		23968	OCT SECURITY	16,811.17	
						23969	SEPT SECURITY	14,255.21	
						23981	OCTOBER SECURITY	5,624.00	
						23982	OCTOBER SECURITY	4,144.00	
						23983	OCTOBER SECURITY	1,628.00	
						23984	OCTOBER SECURITY	1,332.00	
						23985	OCTOBER SECURITY	1,923.44	
31285	12/05/08	100.00	B020	NICOL, KIRBY	7	24157	NOV BOARD MTGS	100.00	
31286	12/05/08	122.17	004	NORTH BAY FORD LINC-MERCURY		23870	REV VEH PARTS	137.65	
						24137	CREDIT NOTE	-15.48	
31287	12/05/08	1,604.96	009	PACIFIC GAS & ELECTRIC		24131	10/4-11/3 KINGS VLG	14.30	
						24145	10/24-11/22 RIVER	93.44	
						24146	10/24-11/22 RIVER	1,433.21	
						24147	10/24-11/22 RIVER	64.01	
31288	12/05/08	870.98	043	PALACE ART & OFFICE SUPPLY		23942	OFFICE SUPPLY/OPS	835.67	
						24014	OFFICE SUPPLIES/FAC	35.31	
31289	12/05/08	494.00	481	PIED PIPER EXTERMINATORS, INC.		24009	NOV PEST CONTROL	183.00	
						24010	NOV PEST CONTROL	241.00	
						24068	NOV PEST CONTROL	70.00	
31290	12/05/08	146.48	050	PITNEY BOWES INC.		24048	1/09-3/09 RENTAL/MTC	146.48	
31291	12/05/08	4,559.78	001149	PREFERRED PLUMBING, INC.		23928	NOV SVC/920 PACIFIC	1,294.00	
						23929	NOV SVC/920 PACIFIC	3,265.78	
31292	12/05/08	3,221.58	156	PRINT GALLERY, THE		24046	PRINTING/MTC	3,221.58	
31293	12/05/08	169.26	882	PRINT SHOP SANTA CRUZ	7	23988	OFFICE SUPPLY/FIN	169.26	
31294	12/05/08	871.57	107A	PROBUILD		23745	PARTS & SUPPLIES	104.38	
						23746	PARTS & SUPPLIES	69.99	
						23808	REPAIRS/MAINTENANCE	68.31	
						23931	REPAIRS/MAINTENANCE	29.27	
						23956	REPAIRS/MAINTENANCE	46.80	
						24003	REPAIRS/MAINTENANCE	38.99	
						24004	REPAIRS/MAINTENANCE	2.32	
						24005	REPAIRS/MAINTENANCE	415.60	
						24006	REPAIRS/MAINTENANCE	60.78	
						24007	REPAIRS/MAINTENANCE	35.13	
31295	12/05/08	241.32	061A	REGISTER PAJARONIAN		23986	CLASS ADV-FINANCE	123.12	
						23987	CLASS ADV-FINANCE	118.20	
31296	12/05/08	100.00	B011	REILLY, EMILY	7	24158	NOV BOARD MTGS	100.00	
31297	12/05/08	100.00	B015	ROTKIN, MIKE	7	24159	NOV BOARD MTGS	100.00	
31298	12/05/08	33,089.15	966	S.C. FUELS	0	23927	NOV DIESEL/FLT	16,476.52	
						23954	NOV DIESEL/FLT	16,612.63	
31299	12/05/08	692.46	002910	SAGE SOFTWARE, INC.		23980	SUPPORT/UPGRADES	692.46	
31300	12/05/08	272.65	018	SALINAS VALLEY FORD SALES		24135	REV VEH PARTS	272.65	
31301	12/05/08	868.78	135	SANTA CRUZ AUTO PARTS, INC.		23777	REV VEH PARTS	70.26	
						23816	PARTS & SUPPLIE	143.37	
						23839	REV VEH PARTS	239.97	
						23841	PARTS & SUPPLIES	6.60	

5-1.4

SANTA CRUZ METROPOLITAN TRANSIT DISTRICT
 CHECK JOURNAL DETAIL BY CHECK NUMBER
 ALL CHECKS FOR ACCOUNTS PAYABLE

DATE: 12/01/08 THRU 12/31/08

CHECK NUMBER	CHECK DATE	CHECK AMOUNT	VENDOR	VENDOR NAME	VENDOR TYPE	TRANS. NUMBER	TRANSACTION DESCRIPTION	TRANSACTION AMOUNT	COMMENT
						23925	EMP TOOL	47.72	
						23951	PARTS & SUPPLIES	49.44	
						23998	PARTS & SUPPLIES	34.32	
						23999	EMP TOOL	115.00	
						24000	REV VEH PARTS	162.10	
31302	12/05/08	130.52	848	SANTA CRUZ ELECTRONICS, INC.		23976	OFFICE SUPPLY/IT	48.55	
						23977	OFFICE SUPPLY/IT	10.80	
						23978	OFFICE SUPPLY/IT	71.17	
31303	12/05/08	10,802.82	079	SANTA CRUZ MUNICIPAL UTILITIES		24023	10/24-11/18 GOLF CLB	116.33	
						24025	10/21-11/18 VERNON	403.34	
						24026	10/21-11/18 RIVER	245.22	
						24027	10/21-11/18 DUBOIS	122.14	
						24028	10/21-11/18 RIVER	1,505.78	
						24029	10/21-11/18 GOLF CLB	994.37	
						24030	10/21-11/18 VERNON	83.31	
						24031	10/21-11/18 RIVER	2,796.08	
						24035	10/21-11/18 DUBOIS	387.32	
						24036	10/21-11/18 ENCINAL	277.98	
						24037	10/21-11/18 CEDAR	863.33	
						24038	10/21-11/19 PACIFIC	2,666.04	
						24039	10/21-11/19 PACIFIC	104.64	
						24148	9/24-11/21 RESEARCH	236.94	
31304	12/05/08	2,500.00	002267	SHAW & YODER, INC.		23973	NOV LEGISLATIVE SVC	2,500.00	
31305	12/05/08	534.60	115	SNAP-ON INDUSTRIAL		23991	EMP TOOLS	139.09	
						24082	EMP TOOLS	115.29	
						24083	SMALL TOOLS	280.22	
31306	12/05/08	555.32	001232	SPECIALIZED AUTO AND		23871	OUT RPR # 318	394.24	
						23872	OUT RPR # 306	161.08	
31307	12/05/08	100.00	B012	SPENCE, PAT	7	24160	NOV BOARD MTGS	100.00	
31308	12/05/08	50.00	B017	STONE, MARK	7	24161	NOV BOARD MTGS	50.00	
31309	12/05/08	2,707.41	002805	TELEPATH CORPORATION		24044	OUT RPR & MAINT	2,707.41	
31310	12/05/08	301.00	002675	THOMSON-WEST BARCLAYS		23952	MOTOR VEHICLES U.S.	301.00	
31311	12/05/08	73.88	007	UNITED PARCEL SERVICE		24002	FRT OUT/FLT	25.02	
						24071	FRT OUT /FLT	48.86	
31312	12/05/08	41,418.64	002829	VALLEY POWER SYSTEMS, INC.		23957	REV VEH PARTS	5,746.51	
						23958	CREDIT NOTE	-5,746.51	
						23959	REV VEH PARTS	5,312.16	
						23960	REV VEH PARTS	64.30	
						23961	CREDIT NOTE	-31.00	
						24060	REV VEH PARTS	1,491.44	
						24061	REV VEH PARTS	433.60	
						24062	REV VEH PARTS	105.01	
						24063	REV VEH PARTS	1,551.72	
						24064	REV VEH PARTS	894.95	
						24065	CONV MUFFLER # 141	2,329.42	
						24066	REMAN ENG # 141	29,225.46	
						24134	PARTS & SUPPLIES	41.58	
31313	12/05/08	333.60	221	VEHICLE MAINTENANCE PROGRAM		24059	REV VEH PARTS	333.60	
31314	12/05/08	53.63	434B	VERIZON CALIFORNIA		24045	MT BIEWLASKI	53.63	
31315	12/05/08	100.86	434	VERIZON WIRELESS	0	23989	2 WIRELESS PC CARDS	100.86	

5-1.5

SANTA CRUZ METROPOLITAN TRANSIT DISTRICT
 CHECK JOURNAL DETAIL BY CHECK NUMBER
 ALL CHECKS FOR ACCOUNTS PAYABLE

DATE: 12/01/08 THRU 12/31/08

CHECK NUMBER	CHECK DATE	CHECK AMOUNT	VENDOR	VENDOR NAME	VENDOR TYPE	TRANS. NUMBER	TRANSACTION DESCRIPTION	TRANSACTION AMOUNT	COMMENT
31316	12/05/08	11,467.50	001043	VISION SERVICE PLAN		23971	DEC VISION INS	11,467.50	
31317	12/05/08	2,490.00	002654	VNA OF SANTA CRUZ	7	23966	OCT FLU SHOTS	2,490.00	
31318	12/05/08	70.00	682	WEISS, AMY L.	7	24164	NOV INTERPRETER	70.00	
31319	12/05/08	459.52	002028	WESTCOAST LEGAL SERVICE	7	24168	PROF SVCS / RISK	74.65	
						24169	PROF SVCS / RISK	74.65	
						24170	PROF SVCS / RISK	74.65	
						24171	PROF SVCS / RISK	74.65	
						24172	PROF SVCS / RISK	160.92	
31320	12/05/08	1,865.30	001506	WESTERN STATES OIL CO., INC.		23955	FUEL & LUBE	948.73	
						24140	FUEL & LUBE	935.28	
							DISCOUNT TAKEN	-18.71	
31321	12/05/08	172.30	147	ZEE MEDICAL SERVICE CO.		24011	SAFETY SUPPLIES	172.30	
31322M	12/09/08	15,599.99	977	SANTA CRUZ TRANSPORTATION, LLC	7	24176	OCT PT SERVICES	15,599.99	VOIDED
31322M	12/18/08	-15,599.99	977	SANTA CRUZ TRANSPORTATION, LLC	7	24176	OCT PT SERVICES	-15,599.99	**VOID
31323M	12/09/08	15,599.99	977	SANTA CRUZ TRANSPORTATION, LLC	7	24177	OCT PT SERVICES	15,599.99	MANUAL
31324	12/19/08	533.44	002069	A TOOL SHED, INC.		24457	12/8 RENTAL/GOLF CLB	533.44	
31325	12/19/08	591.43	001193	AA GLASS SHOP	7	24403	REPAIRS/MAINTENANCE	457.94	
						24404	SVC/SVTC	133.49	
31326	12/19/08	950.08	001263	ABBOTT STREET RADIATOR, INC.		24334	OUT RPR # 9807	475.04	
						24394	OUT RPR # 9814	475.04	
31327	12/19/08	6,605.58	002509	ACCUUNTEMP		24256	TEMP/OPS W/E 11/14	1,949.10	
						24257	TEMP/OPS W/E 11/21	1,901.04	
						24300	TEMP/OPS W/E 11/28	1,345.68	
						24301	TEMP/OPS W/E 12/05	1,409.76	
31328	12/19/08	461.11	020	ADT SECURITY SERVICES INC.		24410	1/09-12-09 ANNUAL	114.95	
						24411	JAN ALARMS	64.46	
						24412	JAN ALARMS	61.90	
						24413	JAN ALARMS	42.71	
						24414	JAN ALARMS	83.77	
						24415	JAN ALARMS	46.66	
						24416	JAN ALARMS	46.66	
31329	12/19/08	1,326.00	382	AIRTEC SERVICE		24179	11/13/08 SERVICE/WTC	340.00	
						24180	11/12/08 SERVICE/PS	375.00	
						24422	SERVICE/ENCINAL	611.00	
31330	12/19/08	250.00	E437	AITKEN, ANGELA		24399	08 HOLIDAY RAFFLE	250.00	
31331	12/19/08	730.00	001016	ALLARD'S SEPTIC SERVICE	7	24280	HAZ WAST DISP	365.00	
						24281	HAZ WASTE DISP	365.00	
31332	12/19/08	15.00	359	AMERICAN MEDICAL RESPONSE WEST		24459	MAY 08 RESEARCH	15.00	
31333	12/19/08	396.42	001	AT&T		24417	DEC REPEATERS/OPS	396.42	
31334	12/19/08	3,776.66	001B	AT&T/MCI		24284	OCT PHONES	3,776.66	
31335	12/19/08	828.59	876	ATCHISON, BARISONE, CONDOTTI &	7	24458	LEGAL SVCS/425 FRONT	828.59	
31336	12/19/08	89.00	001856	BAY COMMUNICATIONS	7	24290	SVC/ADM/VERNON	89.00	
31337	12/19/08	6,452.59	664	BAY COUNTIES PITCOCK PETROLEUM		24202	NOV FUEL & LUBE	6,452.59	
31338	12/19/08	960.00	011	BEWLEYS CLEANING	7	24200	SERVICE/1217 RIVER	960.00	
31339	12/19/08	70.31	034	BLUEPRINT EXPRESS	7	24391	PRINTING/FAC	70.31	
31340	12/19/08	13,500.00	616	BROWN ARMSTRONG		24398	08 AUDIT SERVICES	13,500.00	
31341	12/19/08	2,424.32	002189	BUS & EQUIPMENT		24240	REV VEH PARTS	558.62	

5-1.6

SANTA CRUZ METROPOLITAN TRANSIT DISTRICT
 CHECK JOURNAL DETAIL BY CHECK NUMBER
 ALL CHECKS FOR ACCOUNTS PAYABLE

DATE: 12/01/08 THRU 12/31/08

CHECK NUMBER	CHECK DATE	CHECK AMOUNT	VENDOR	VENDOR NAME	VENDOR TYPE	TRANS. NUMBER	TRANSACTION DESCRIPTION	TRANSACTION AMOUNT	COMMENT
						24241	REV VEH PARTS	225.83	
						24242	REV VEH PARTS	221.70	
						24243	REV VEH PARTS	272.81	
						24244	REV VEH PARTS	443.86	
						24298	REV VEH PARTS	85.02	
						24379	REV VEH PARTS	329.87	
						24380	REV VEH PARTS	90.91	
						24381	REV VEH PARTS	168.02	
						24382	REV VEH PARTS	27.68	
31342	12/19/08	13,549.00	694	CALIFORNIA TRANSIT ASSOC.		24400	2009 ANNUAL DUES	13,549.00	
31343	12/19/08	89.50	002898	CEB		24408	CA WORKERS 08 UPDATE	89.50	
31344	12/19/08	10.80	172	CENTRAL WELDER'S SUPPLY, INC.		24389	CYLINDER RENTAL	10.80	
31345	12/19/08	5,000.00	002346	CHANEY, CAROLYN & ASSOC., INC.		24089	DEC LEGISLATIVE SVC	5,000.00	
31346	12/19/08	8.00	T174	CHRISTIERTSON, ERIC V.		24291	REFUND \$10-\$2 FARE	8.00	
31347	12/19/08	10.63	130	CITY OF WATSONVILLE UTILITIES		24330	11/1-12/1 RODRIGUEZ	10.63	
31348	12/19/08	4,685.25	909	CLASSIC GRAPHICS		24396	OUT RPR # 9829	4,685.25	
31349	12/19/08	45,578.32	001124	CLEAN ENERGY		24203	11/28 LNG/FLT	9,155.33	
						24204	11/24 LNG/FLT	8,937.15	
						24423	DEC LNG/FLT	17,922.36	
						24424	DEC LNG/FLT	9,563.48	
31350	12/19/08	51,176.92	002569	COMERICA BANK		24174	WORK COMP FUND	51,176.92	
31351	12/19/08	39.09	002063	COSTCO		24305	PHOTO PROCESS/OPS	7.70	
						24306	PHOTO PROCESS/OPS	8.90	
						24307	PHOTO PROCESS/OPS	1.71	
						24308	PHOTO PROCESS/OPS	2.53	
						24309	PHOTO PROCESS/OPS	4.84	
						24352	PHOTO PROCESS/OPS	5.83	
						24353	PHOTO PROCESS/OPS	2.20	
						24354	PHOTO PROCESS/OPS	2.20	
						24355	PHOTO PROCESS/OPS	3.18	
31352	12/19/08	1,086.98	001048	CRUZ CAR WASH		24239	OUT RPR REV VEH	1,086.98	
31353	12/19/08	3.53	504	CUMMINS WEST, INC.		24420	REV VEH PARTS	73.56	
						24421	CREDIT NOTE	-70.03	
31354	12/19/08	201.42	001000	DAIMLER BUSES N. AMERICA INC.		24255	REV VEH PARTS	201.42	
31355	12/19/08	1,651.46	753	DEPARTMENT OF GENERAL SERVICES		24405	PURCHASE FEES	1,696.79	
						24438	CREDIT NOTE	-45.33	
31356	12/19/08	1,654.06	001316	DEVCO OIL		24293	11/15-11/30 FUEL/FLT	1,654.06	
31357	12/19/08	1,426.78	480	DIESEL MARINE ELECTRIC, INC.		24333	REV VEH PARTS	1,426.78	
31359	12/19/08	16,320.50	085	DIXON & SON TIRE, INC.		24207	TIRES & TUBES	845.79	
						24208	TIRES & TUBES	1,305.14	
						24209	TIRES & TUBES	696.75	
						24210	TIRES & TUBES	1,305.14	
						24211	TIRES & TUBES	843.42	
						24212	TIRES & TUBES	696.75	
						24213	TIRES & TUBES	844.20	
						24214	TIRES & TUBES	422.89	
						24215	TIRES & TUBES	464.50	
						24216	TIRES & TUBES	422.10	
						24217	TIRES & TUBES	659.02	
						24218	TIRES & TUBES	174.60	

5-1.7

SANTA CRUZ METROPOLITAN TRANSIT DISTRICT
 CHECK JOURNAL DETAIL BY CHECK NUMBER
 ALL CHECKS FOR ACCOUNTS PAYABLE

DATE: 12/01/08 THRU 12/31/08

CHECK NUMBER	CHECK DATE	CHECK AMOUNT	VENDOR	VENDOR NAME	VENDOR TYPE	TRANS. NUMBER	TRANSACTION DESCRIPTION	TRANSACTION AMOUNT	COMMENT
						24219	TIRES & TUBES	120.90	
						24220	TIRES & TUBES	839.34	
						24221	TIRES & TUBES	1,647.54	
						24222	TIRES & TUBES	978.86	
						24223	TIRES & TUBES	1,055.25	
						24224	TIRES & TUBES	428.54	
						24225	TIRES & TUBES	696.75	
						24226	TIRES & TUBES	33.00	
						24227	TIRES & TUBES	15.00	
						24228	TIRES & TUBES	33.00	
						24229	TIRES & TUBES	74.40	
						24230	TIRES & TUBES	93.00	
						24231	TIRES & TUBES	99.00	
						24232	TIRES & TUBES	87.30	
						24233	TIRES & TUBES	33.00	
						24234	TIRES & TUBES	33.00	
						24235	TIRES & TUBES	414.21	
						24236	TIRES & TUBES	505.59	
						24237	TIRES & TUBES	328.14	
						24238	TIRES & TUBES	15.00	
						24378	TIRES & TUBES	109.38	
31360	12/19/08	500.00	002862	ECOLOGICAL CONCERNS INC.		24447	WATER DRAINAGE/ME	500.00	
31361	12/19/08	249.00	861	EMPLOYER RESOURCE INSTITUTE		24310	CA EMP ADVISOR/RENEW	249.00	
31362	12/19/08	67.40	298	ERGOMETRICS		24384	SCORING SERVICES	67.40	
31363	12/19/08	360.50	001492	EVERGREEN OIL INC.		24289	HAZ WASTE DISP	137.50	
						24406	HAZ WASTE DISP	223.00	
31364	12/19/08	900.00	432	EXPRESS EMPLOYMENT PROS		24439	TEMP/FLT W/E 12/7	900.00	
31365	12/19/08	165.00	002295	FIRST ALARM		24444	PROF/TECH SVCS	165.00	
31366	12/19/08	6,765.25	001158	FRICKE PARKS PRESS INC		24295	NOV PRINTING/MTC	6,765.25	
31367	12/19/08	13.75	001199	GHARAHGOZLOO, ALI		24455	CHANGE FUND/JESSICA	13.75	
31368	12/19/08	3,853.12	117	GILLIG LLC		24331	REV VEH PARTS	184.06	
						24342	REV VEH PARTS	1,793.98	
						24387	REV VEH PARTS	1,714.30	
						24388	REV VEH PARTS	160.78	
31369	12/19/08	473.02	001097	GREENWASTE RECOVERY, INC.		24335	NOV GARB/GREEN VLY	17.50	
						24336	NOV GARB/RESEARCH	210.52	
						24337	NOV GARB/KINGS VLG	174.55	
						24338	NOV GARB/KINGS VLG	70.45	
31370	12/19/08	108,167.51	001035	HARRIS & ASSOCIATES		24453	SVC THRU 10/31 MB	60,974.75	
						24460	SVC THRU 11/30 MB	47,002.76	
						24466	SVC THRU 11/30 MB	190.00	
31371	12/19/08	6,773.00	001144	HARTFORD INSURANCE CO		23807	1/09-1/10 FLOOD INS	6,773.00	
31372	12/19/08	89.87	510A	HASLER, INC.		24383	1/01-1/31 RENTAL/PT	41.04	
						24448	JAN POSTAGE/ADM	48.83	
31373	12/19/08	65.45	E021	HILTNER, THOMAS		24260	OFFICE SUPPLIES	21.13	
						24261	COPIES/JARC SVC PLN	44.32	
31374	12/19/08	29,548.30	002116	HINSHAW, EDWARD & BARBARA	7	24265	370 ENCINAL RENT	29,548.30	
31375	12/19/08	508.15	210	HOLIDAY MUFFLER AND BRAKES		24365	OUT RPR REV VEH	508.15	
31376	12/19/08	32.56	166	HOSE SHOP, THE		24393	PARTS & SUPPLIES	32.56	
31377	12/19/08	247.58	215	IKON OFFICE SOLUTIONS		24450	10/17-11/19 MAIN/ADM	247.58	

5-1.8

SANTA CRUZ METROPOLITAN TRANSIT DISTRICT
 CHECK JOURNAL DETAIL BY CHECK NUMBER
 ALL CHECKS FOR ACCOUNTS PAYABLE

DATE: 12/01/08 THRU 12/31/08

CHECK NUMBER	CHECK DATE	CHECK AMOUNT	VENDOR	VENDOR NAME	VENDOR TRANS. TYPE	TRANS. NUMBER	TRANSACTION DESCRIPTION	TRANSACTION AMOUNT	COMMENT
31378	12/19/08	15,308.20	002117	IULIANO	7	24266	111 DUBOIS RENT	12,036.59	
						24269	115 DUBOIS RENT	3,271.61	
31379	12/19/08	10.00	E345	JACINTO, FRANK		24259	DMV FEES	10.00	
31380	12/19/08	2,820.54	110	JESSICA GROCERY STORE, INC.		24270	CUSTODIAL SVCS	2,820.54	
31381	12/19/08	75.52	220	JONES COMPANY, THE ED		24303	UNIF/LAUNDRY/OPS	75.52	
31382	12/19/08	4,569.00	878	KELLY SERVICES, INC.		24262	TEMP/OPS W/E 11/02	1,920.00	
						24263	TEMP/OPS W/E 11/09	744.00	
						24264	TEMP/OPS W/E 11/16	969.00	
						24299	TEMP/OPS W/E 11/30	576.00	
						24419	TEMP/FLT W/E 12/07	360.00	
31383	12/19/08	63.77	036	KELLY-MOORE PAINT CO., INC.		24392	REPAIRS/MAINTENANCE	63.77	
31384	12/19/08	23.20	167	KEYSTON BROTHERS		24332	OTH MOB SUPPLIES	23.20	
31385	12/19/08	421.46	001233	KIMBALL MIDWEST		24341	REV VEH PARTS	421.46	
31386	12/19/08	1,338.83	039	KINKO'S INC.		24356	DEC PRINTING/MTC	362.82	
						24357	DEC PRINTING/MTC	427.50	
						24358	PRINTING/OPS	548.51	
31387	12/19/08	269.50	001093	KROLL LABORATORY SPECIALISTS		24287	OCT/NOV DRUG TESTS	269.50	
31388	12/19/08	900.00	852	LAW OFFICES OF MARIE F. SANG	7	24282	WORKERS COMP CLAIM	900.00	
31389	12/19/08	30.00	880	LEXISNEXIS		24385	PROF/TECH SVC/RISK	30.00	
31390	12/19/08	1,407.05	001119	MACERICH PARTNERSHIP LP	7	24268	CAPITOLA MALL RENT	1,407.05	
31391	12/19/08	75.00	E048	MARTINEZ, MARK		24302	MEDICAL EXAM	75.00	
31392	12/19/08	300.00	001247	MASTER STEAM SERVICES	7	24288	SVC/EL DANDY	300.00	
31393	12/19/08	650.00	764	MERCURY METALS		24253	OUT RPR REV VEH	650.00	
31394	12/19/08	1,246.92	041	MISSION UNIFORM		23992	UNIF/LAUNDRY/FLT	299.17	
						23993	UNIF/LAUNDRY/FLT	50.60	
						23994	UNIF/LAUNDRY/FLT	127.26	
						23995	UNIF/LAUNDRY/FLT	43.26	
						24008	UNIF/LAUNDRY/FAC	67.89	
						24323	UNIF/LAUNDRY/FLT	127.26	
						24324	UNIF/LAUNDRY/FLT	299.17	
						24325	UNIF/LAUNDRY/FAC	69.60	
						24326	UNIF/LAUNDRY/FLT	50.60	
						24327	UNIF/LAUNDRY/FLT	43.26	
						24328	UNIF/LAUNDRY/PT	35.42	
						24329	UNIF/LAUNDRY/PT	33.43	
31395	12/19/08	14,571.90	001225	NATIONAL SECURITY SERVICE		24429	NOV SECURITY	5,476.00	
						24430	NOV SECURITY	3,552.00	
						24431	NOV SECURITY	1,961.00	
						24432	NOV SECURITY	1,628.00	
						24433	NOV SECURITY	1,954.90	
31396	12/19/08	1,381.30	002721	NEXTEL COMMUNICATIONS		24366	NOV PHONES/PT	1,381.30	
31397	12/19/08	956.07	004	NORTH BAY FORD LINC-MERCURY		24136	REV VEH PARTS	15.48	
						24138	REV VEH PARTS	7.23	
						24361	REV VEH PARTS	23.72	
						24364	OUT RPR REV VEH	909.64	
31398	12/19/08	14,842.00	001176	NORTHSTAR, INC.		24201	NOV MAINT/LCNG RIVER	14,842.00	
31399	12/19/08	250.00	002385	OPTIMUM BUSINESS SERVICES, INC 0		24456	MOVE COPIER TO GOLF	250.00	
31400	12/19/08	108.25	001002	ORACLE CORPORATION		23738	SUPPORT/UPDATE	108.25	
31401	12/19/08	14,133.22	009	PACIFIC GAS & ELECTRIC		24178	10/24-11/24 115 DUB	167.63	
						24181	10/24-11/24 115 DUB	15.18	

5-1.9

SANTA CRUZ METROPOLITAN TRANSIT DISTRICT
 CHECK JOURNAL DETAIL BY CHECK NUMBER
 ALL CHECKS FOR ACCOUNTS PAYABLE

DATE: 12/01/08 THRU 12/31/08

CHECK NUMBER	CHECK DATE	CHECK AMOUNT	VENDOR	VENDOR NAME	VENDOR TYPE	TRANS. NUMBER	TRANSACTION DESCRIPTION	TRANSACTION AMOUNT	COMMENT
						24182	10/24-11/22 ENCINAL	2,775.10	
						24183	10/24-11/22 110 VERN	1,552.60	
						24184	10/24-11/24 115 DUB	17.85	
						24277	10/29-11/26 PACIFIC	1,781.51	
						24278	10/24-11/24 DUBOIS	4,618.41	
						24286	11/4-12/4 KINGS VLG	28.60	
						24401	10/23-12/4 RODRIGUEZ	2,162.22	
						24418	NOV PHONES/RESEARCH	1,014.12	
31402	12/19/08	140.36	002809	PACIFIC PROPANE		24304	12/3 EQUIP RENTAL	140.36	
31403	12/19/08	1,336.78	043	PALACE ART & OFFICE SUPPLY		24084	OFFICE SUPPLIES/FIN	373.41	
						24163	OFFICE SUPPLY/ADM	455.57	
						24297	OFFICE SUPPLY/OPS	154.07	
						24345	OFFICE SUPPLY/FIN	32.65	
						24348	OFFICE SUPPLY/MTC	265.97	
						24349	OFFICE SUPPLY/MTC	17.89	
						24350	OFFICE SUPPLY/MTC	22.04	
						24351	CREDIT MEMO	-16.26	
						24454	OFFICE SUPPLY/ADM	31.44	
31404	12/19/08	887.00	950	PARADISE LANDSCAPE INC	0	24386	DEC MAINTENANCE	887.00	
31405	12/19/08	1,525.32	002823	PAT PIRAS CONSULTING	7	24443	PROF SVCS /PT	1,525.32	
31406	12/19/08	1,019.50	481	PIED PIPER EXTERMINATORS, INC.		24271	NOV PEST CONTROL	53.00	
						24272	NOV PEST CONTROL	48.50	
						24273	NOV PEST CONTROL	48.50	
						24319	SVC/DUBOIS	225.50	
						24320	DEC PEST CONTROL	241.00	
						24321	DEC PEST CONTROL	183.00	
						24434	DEC PEST CONTROL	53.00	
						24435	DEC PEST CONTROL	48.50	
						24436	DEC PEST CONTROL	70.00	
						24437	DEC PEST CONTROL	48.50	
31407	12/19/08	797.00	001149	PREFERRED PLUMBING, INC.		24402	SVC/CAFE LENA	797.00	
31408	12/19/08	618.29	156	PRINT GALLERY, THE		24296	PRINTING/MTC	618.29	
31409	12/19/08	394.31	107A	PROBUILD		24043	REPAIRS/MAINTENANCE	15.59	
						24069	REPAIRS/MAINTENANCE	16.76	
						24070	REPAIRS/MAINTENANCE	260.11	
						24196	REPAIRS/MAINTENANCE	11.48	
						24197	REPAIRS/MAINTENANCE	80.83	
						24198	REPAIRS/MAINTENANCE	3.80	
						24199	REPAIRS/MAINTENANCE	0.09	
						24318	REPAIRS/MAINTENANCE	5.65	
31410	12/19/08	123.12	061A	REGISTER PAJARONIAN		24407	GLASS AD/FINANCE	123.12	
31411	12/19/08	45,765.96	904	RNL DESIGN		24467	SVCS THRU 10/31 MB	31,837.53	
						24468	SVCS THRU 10/31 MB	13,843.25	
						24469	SVCS THRU 10/31 MB	85.18	
31412	12/19/08	27,439.44	966	S.C. FUELS	0	24205	11/25 DIESEL/FLT	13,934.17	
						24441	12/6 DIESEL/FLT	13,505.27	
31413	12/19/08	1,114.83	001379	SAFETY-KLEEN		24397	HAZ WASTE DISP	1,114.83	
31414	12/19/08	873.95	018	SALINAS VALLEY FORD SALES		24395	REV VEH PARTS	873.95	
31415	12/19/08	356.60	002713	SANTA CRUZ AUTO TECH, INC.		24206	OUT RPR REV VEH	356.60	
31416	12/19/08	446.44	135	SANTA CRUZ AUTO PARTS, INC.		24067	PARTS & SUPPLIES	61.85	

5-1.10

SANTA CRUZ METROPOLITAN TRANSIT DISTRICT
 CHECK JOURNAL DETAIL BY CHECK NUMBER
 ALL CHECKS FOR ACCOUNTS PAYABLE

DATE: 12/01/08 THRU 12/31/08

CHECK NUMBER	CHECK DATE	CHECK AMOUNT	VENDOR	VENDOR NAME	VENDOR TYPE	TRANS. NUMBER	TRANSACTION DESCRIPTION	TRANSACTION AMOUNT	COMMENT
						24139	PARTS & SUPPLIES	21.94	
						24192	REV VEH PARTS	112.34	
						24193	REV VEH PARTS	4.85	
						24194	CREDIT MEMO	-85.42	
						24195	REV VEH PARTS	87.57	
						24312	PARTS & SUPPLIES	22.21	
						24313	REV VEH PARTS	129.06	
						24314	REV VEH PARTS	66.07	
						24315	REV VEH PARTS	25.97	
31417	12/19/08	618.47	149	SANTA CRUZ SENTINEL	0	24293	NOV ADVERTISING/FIN	196.72	
						24294	NOV ADVERTISING/FIN	190.76	
						24449	PUB NOTICE ADM 11/6	230.99	
31418	12/19/08	10,542.93	977	SANTA CRUZ TRANSPORTATION, LLC	7	24452	NOV PT SVCS	10,542.93	
31419	12/19/08	456.70	788	SCMTD PETTY CASH - FINANCE		24285	PETTY CASH/FINANCE	456.70	
31420	12/19/08	246.00	957	SECURITY SHORING & STEEL PLT		24339	10/28-11/27 RENTAL	246.00	
31421	12/19/08	2,500.00	002267	SHAW & YODER, INC.		24425	DEC LEGISLATIVE SVC	2,500.00	
31422	12/19/08	100.00	B016	SKILLICORN, DALE	7	24445	DEC BOARD MTGS	100.00	
31423	12/19/08	12,116.23	001075	SOQUEL III ASSOCIATES	7	24267	RESEARCH PARK RENT	12,116.23	
31424	12/19/08	5,620.83	001232	SPECIALIZED AUTO AND		24246	OUT RPR REV VEH	366.93	
						24247	OUT RPR REV VEH	415.78	
						24248	OUT RPR REV VEH	341.15	
						24249	OUT RPR REV VEH	277.46	
						24250	OUT RPR REV VEH	192.74	
						24251	OUT RPR REV VEH	330.02	
						24252	OUT RPR REV VEH	302.49	
						24367	OUT RPR REV VEH	674.06	
						24368	OUT RPR REV VEH	192.74	
						24369	OUT RPR REV VEH	192.74	
						24370	OUT RPR REV VEH	321.92	
						24371	OUT RPR REV VEH	127.17	
						24372	OUT RPR REV VEH	725.59	
						24373	OUT RPR REV VEH	192.74	
						24374	OUT RPR REV VEH	922.00	
						24375	OUT RPR REV VEH	45.30	
31425	12/19/08	475.00	001930	STATE BAR OF CALIFORNIA		24311	2009 MEMBERSHIP	475.00	
31426	12/19/08	6,397.00	080	STATE BOARD OF EQUALIZATION		24428	NOV USE TAX PREPAY	6,397.00	
31427	12/19/08	9,279.88	001648	STEVE'S UNION SERVICE		24254	NOV FUELS & LUBE/PT	9,279.88	
31428	12/19/08	548.55	002805	TELEPATH CORPORATION		24440	RADIO REMOVAL/# 8077	548.55	
31429	12/19/08	38,416.82	970	THE MECHANICS BANK		24427	AUG RETAINAGE/MB	38,416.82	
31430	12/19/08	4,191.40	001800	THERMO KING OF SALINAS, INC		24185	11/18 REV VEH PARTS	351.51	
						24186	11/10 PARTS & SUPPLY	633.26	
						24187	11/10 RPR #9831	3,206.63	
31431	12/19/08	85.00	E197	TICHENOR, KENNETH		24258	MEDICAL EXAM	85.00	
31432	12/19/08	4,419.14	057	U.S. BANK		24461	4246044555645971	112.81	
						24462	4246044555645971	770.95	
						24463	4246044555645971	363.17	
						24464	4246044555645971	537.28	
						24465	4246044555645971	2,634.93	
31433	12/19/08	40.40	007	UNITED PARCEL SERVICE		24279	FRT OUT/FLT	40.40	
31434	12/19/08	10.83	946	UNITED SITE SERVICES		24390	NOV FENCE RENT/DUB	10.83	

5-1.11

SANTA CRUZ METROPOLITAN TRANSIT DISTRICT
 CHECK JOURNAL DETAIL BY CHECK NUMBER
 ALL CHECKS FOR ACCOUNTS PAYABLE

DATE: 12/01/08 THRU 12/31/08

CHECK NUMBER	CHECK DATE	CHECK AMOUNT	VENDOR	VENDOR NAME	TRANS. TYPE	TRANS. NUMBER	TRANSACTION DESCRIPTION	TRANSACTION AMOUNT	COMMENT
31435	12/19/08	560.64	001140	UNIVERSITY INN &		24409	HOLIDAY PARTY	560.64	
31436	12/19/08	856.89	002829	VALLEY POWER SYSTEMS, INC.		24340	REV VEH PARTS	244.82	
						24343	REV VEH PARTS	34.00	
						24344	REV VEH PARTS	578.07	
31437	12/19/08	16,417.36	001239	WALD, RUHNKE & DOST ARCHITECTS		24446	A&E SERVICES/VERNON	16,417.36	
31438	12/19/08	10,052.44	001083	WATSONVILLE TRANSPORTATION, INC		24451	NOV PT SVCS	10,052.44	
31439	12/19/08	2,534.70	001223	WATSONVILLE CADILLAC, BUICK,		24188	REV VEH PARTS	642.92	
						24189	REV VEH PARTS	131.21	
						24190	REV VEH PARTS	45.79	
						24191	REV VEH PARTS	389.78	
						24245	OUT RPR REV VEH	990.41	
						24317	REV VEH PARTS	334.59	
31440	12/19/08	70.00	682	WEISS, AMY L.	7	23397	OCT INTERPRETER	70.00	
31441	12/19/08	345,751.38	002887	WEST BAY BUILDERS, INC.		24426	CONST SVC MB TO 8/08	345,751.38	
31442	12/19/08	279.17	436	WEST PAYMENT CENTER		24292	NOV ACCESS CHARGE	279.17	
31443	12/19/08	137.03	042	WFCB-OSH COMMERCIAL SERVICES		24274	REPAIRS/MAINTENANCE	21.14	
						24275	REPAIRS/MAINTENANCE	68.17	
						24276	CASH BACK CREDIT	-16.16	
						24347	OFFICE SUPPLY/MTC	11.78	
						24442	REV VEH PARTS	52.10	
31444	12/19/08	94.07	147	ZEE MEDICAL SERVICE CO.		24363	SAFETY SUPPLIES	94.07	
31445	12/19/08	56.06	M033	BAILEY, NEIL	0	24470	MED PYMT SUPP	56.06	MANUAL
							MED PYMT SUPP		
31446	12/19/08	28.03	M036	CERVANTES, GLORIA	0	24471	MED PYMT SUPP	28.03	MANUAL
							MED PYMT SUPP		
31447	12/19/08	28.03	M039	DAVILA, ANA MARIA	0	24472	MED PYMT SUPP	28.03	MANUAL
							MED PYMT SUPP		
31448	12/19/08	28.03	M040	GARBEZ, LINDA	0	24473	MED PYMT SUPP	28.03	MANUAL
							MED PYMT SUPP		
31449	12/19/08	56.06	M100	GARCIA, SANTIAGO	0	24474	MED PYMT SUPP	56.06	MANUAL
							MED PYMT SUPP		
31450	12/19/08	56.06	M041	GOUBEIA, ROBERT	0	24475	MED PYMT SUPP	56.06	MANUAL
							MED PYMT SUPP		
31451	12/19/08	72.94	M081	HALL, JAMES	0	24476	MED PYMT SUPP	72.94	MANUAL
							MED PYMT SUPP		
31452	12/19/08	28.03	M050	O'MARA, KATHLEEN	0	24477	MED PYMT SUPP	28.03	MANUAL
							MED PYMT SUPP		
31453	12/19/08	28.03	M109	PEREZ, CHERYL		24478	MED PYMT SUPP	28.03	MANUAL
							MED PYMT SUPP		
31454	12/19/08	56.06	M085	ROSSI, DENISE	0	24479	MED PYMT SUPP	56.06	MANUAL
							MED PYMT SUPP		
31455	12/19/08	28.03	M030	ROWE, RUBY		24480	MED PYMT SUPP	28.03	MANUAL
							MED PYMT SUPP		
31456	12/19/08	56.06	M054	SLOAN, FRANCIS	0	24481	MED PYMT SUPP	56.06	MANUAL
							MED PYMT SUPP		
31457	12/19/08	28.03	M086	TOLINE, DONALD	0	24482	MED PYMT SUPP	28.03	MANUAL
							MED PYMT SUPP		
31458	12/19/08	28.03	M088	YAGI, RANDY	0	24483	MED PYMT SUPP	28.03	MANUAL
							MED PYMT SUPP		
31459	12/19/08	218.96	M005	ROSS, EMERY	0	24484	MED PYMT SUPP	218.96	MANUAL

5-1.12

SANTA CRUZ METROPOLITAN TRANSIT DISTRICT
 CHECK JOURNAL DETAIL BY CHECK NUMBER
 ALL CHECKS FOR ACCOUNTS PAYABLE

DATE: 12/01/08 THRU 12/31/08

CHECK NUMBER	CHECK DATE	CHECK AMOUNT	VENDOR	VENDOR NAME	VENDOR TYPE	TRANS. NUMBER	TRANSACTION DESCRIPTION	TRANSACTION AMOUNT	COMMENT
31460M12/19/08		56.06	M022	MED PYMT SUPP CAPELLA, KATHLEEN	0	24485	MED PYMT SUPP	56.06	MANUAL
31461M12/19/08		28.03	M069	MED PYMT SUPP JACOBS, KENNETH	0	24486	MED PYMT SUPP	28.03	MANUAL
31462M12/19/08		246.99	M061	MED PYMT SUPP KAMEDA, TERRY	0	24487	MED PYMT SUPP	246.99	MANUAL
31463M12/19/08		217.29	M057	MED PYMT SUPP PARHAM, WALLACE	0	24488	MED PYMT SUPP	217.29	MANUAL
31464M12/19/08		180.17	M064	MED PYMT SUPP PETERS, TERRIE	0	24489	MED PYMT SUPP	180.17	MANUAL
31465M12/19/08		28.03	M070	MED PYMT SUPP PICARELLA, FRANCIS	0	24490	MED PYMT SUPP	28.03	MANUAL
31466M12/19/08		217.29	M058	MED PYMT SUPP POTEETE, BEVERLY	0	24491	MED PYMT SUPP	217.29	MANUAL
31467M12/19/08		156.17	M010	MED PYMT SUPP SHORT, SLOAN	0	24492	MED PYMT SUPP	156.17	MANUAL
31468M12/19/08		28.03	M073	MED PYMT SUPP CENTER, DOUG	0	24493	MED PYMT SUPP	28.03	MANUAL
31469M12/19/08		28.03	M092	MED PYMT SUPP CRAWFORD, TERRI	0	24494	MED PYMT SUPP	28.03	MANUAL
31470M12/19/08		28.03	M096	MED PYMT SUPP DRAKE, JUDITH	0	24495	MED PYMT SUPP	28.03	MANUAL
31471M12/19/08		28.03	M099	MED PYMT SUPP FIKE, LOUIS	0	24496	MED PYMT SUPP	28.03	MANUAL
31472M12/19/08		67.46	M074	MED PYMT SUPP GABRIELE, BERNARD	0	24497	MED PYMT SUPP	67.46	MANUAL
31473M12/19/08		28.03	M101	MED PYMT SUPP GOES, ALAN	0	24498	MED PYMT SUPP	28.03	MANUAL
31474M12/19/08		28.03	M104	MED PYMT SUPP JUSSEL, PETE	0	24499	MED PYMT SUPP	28.03	MANUAL
31475M12/19/08		28.03	M117	MED PYMT SUPP POLANCO, ANDRES		24500	MED PYMT SUPP	28.03	MANUAL
31476M12/19/08		28.03	M112	MED PYMT SUPP SILVA, EDUARDO	0	24501	MED PYMT SUPP	28.03	MANUAL
31477M12/19/08		217.29	M076	MED PYMT SUPP VONWAL, YVETTE	0	24502	MED PYMT SUPP	217.29	MANUAL
TOTAL		1,830,608.15		ACCOUNTS PAYABLE			TOTAL CHECKS	256	1,830,608.15
							DISCOUNT		18.71
							A/P TOTAL		1,830,626.86

5-1.13

SANTA CRUZ METROPOLITAN TRANSIT DISTRICT

DATE: January 23, 2009
TO: Board of Directors
FROM: Angela Aitken, Finance Manager
SUBJECT: MONTHLY BUDGET STATUS REPORTS FOR NOVEMBER 2008.

I. RECOMMENDED ACTION

That the Board of Directors accept and file the budget status reports for the month of November 2008.

II. SUMMARY OF ISSUES

- **Operating Revenues** for the month of November 2008 were \$43K or 2 % under the amount of revenue expected for November 2008.
- **Consolidated Operating Expenses** for the month of November 2008 were \$200K or 6 % under budget.
- **Capital Budget** spending year to date through November 2008 was \$9,227K or 27 % of the Capital budget.

III. DISCUSSION

An analysis of the District's budget status is prepared monthly in order to apprise the Board of Directors of the District's actual revenues, expenses and capital in relation to the adopted operating and capital budgets for the fiscal year. The attached monthly revenue, expense and capital reports represent the status of the District's FY09 operating and capital budgets versus actual expenditures for the month.

The fiscal year has elapsed **42%**.

5-2.1

A. Operating Revenue

For the month of November 2008 revenue was \$43K or 2 % under the amount of revenue expected for the month. Revenue variances are explained in the notes at the end of the revenue report.

B. Operating Expense by Department

Total Operating Expenses by Department for the month of November 2008 were \$200K or 6 % under budget; 4 % over where we were in FY08. Majority of the variance is due to lower than anticipated Personnel expenses in Operations and Fleet, Settlement costs in Risk Management, and Fuel & Lube Rev Vehicles expenses in Fleet.

C. Consolidated Operating Expenses

Consolidated Operating Expenses for the month of November 2008 were \$200K or 6 % under budget. Personnel Expenses, Prof & Tech Fees, and Fuels & Lube Rev Veh all contributed to the variance. Further explanation of these accounts is contained in the notes following the report.

D. Capital Budget

Capital Budget spending year to date through November 2008 was \$9,227K or 27 % of the Capital budget. Of this, \$1,701K has been spent of the MetroBase Maintenance Facility line item, \$3,561K has been spent on the Local Bus Replacement , \$1,383K has been spent on the CNG Bus Conversions, and \$2,351K has been spent on the H17 Bus Replacement project.

IV. FINANCIAL CONSIDERATIONS

At this time, our Operating and Capital Budget is within tolerable variances.

IV. ATTACHMENTS

Attachment A: FY09 Operating Revenue for the month ending – 11/30/08
FY09 Operating Expenses by Department for the month ending – 11/30/08
FY09 Consolidated Operating Expenses for the month ending – 11/30/08
FY09 Capital Budget Reports for the month ending – 11/30/08

Prepared by: Kristina Mihaylova

5-2.2



FY09
Operating Revenue
For the month ending - November 30, 2008

Percent of Year Elapsed - 42%

Revenue Source	Current Period					Year to Date				YTD Year Over Year Comparison			
	Actual	Budget	\$ Var	% Var	Notes	Actual	Budget	\$ Var	% Var	FY09 Actual	FY08	\$ Var	% Var
Passenger Fares	\$ 231,712	\$ 260,629	\$ (28,917)	-11%		\$ 1,480,725	\$ 1,481,804	\$ (1,079)	0%	\$ 1,480,725	\$ 1,531,658	\$ (50,933)	-3%
Paratransit Fares	\$ 39,565	\$ 25,088	\$ 14,477	58%		\$ 158,952	\$ 107,518	\$ 51,434	48%	\$ 158,952	\$ 96,039	\$ 62,913	66%
Special Transit Fares	\$ 347,590	\$ 298,741	\$ 48,849	16%		\$ 1,265,342	\$ 1,102,401	\$ 162,941	15%	\$ 1,265,342	\$ 831,898	\$ 433,444	52%
Highway 17 Fares	\$ 95,232	\$ 69,706	\$ 25,526	37%		\$ 445,207	\$ 348,608	\$ 96,599	28%	\$ 445,207	\$ 338,436	\$ 106,771	32%
Highway 17 Payments	\$ 31,856	\$ 40,387	\$ (8,531)	-21%		\$ 179,938	\$ 221,499	\$ (41,561)	-19%	\$ 179,938	\$ 200,345	\$ (20,407)	-10%
Subtotal Passenger Revenue	\$ 745,955	\$ 694,551	\$ 51,404	7%	1	\$ 3,530,164	\$ 3,261,830	\$ 268,334	8%	\$ 3,530,164	\$ 2,998,376	\$ 531,788	18%
Commissions	\$ 1,481	\$ 456	\$ 1,025	225%		\$ 3,185	\$ 2,284	\$ 901	39%	\$ 3,185	\$ 2,362	\$ 823	35%
Advertising Income	\$ 8,370	\$ 7,700	\$ 670	9%		\$ 59,635	\$ 38,500	\$ 21,135	55%	\$ 59,635	\$ 127,626	\$ (67,991)	-53%
Rent Income - SC Pacific Station	\$ 7,512	\$ 6,919	\$ 593	9%		\$ 37,374	\$ 34,595	\$ 2,779	8%	\$ 37,374	\$ 30,397	\$ 6,977	23%
Rent Income - Watsonville, TC	\$ 2,821	\$ 3,851	\$ (1,030)	-27%		\$ 16,737	\$ 19,255	\$ (2,518)	-13%	\$ 16,737	\$ 17,965	\$ (1,228)	-7%
Rent Income - General	\$ 795	\$ -	\$ 795	100%		\$ 11,864	\$ -	\$ 11,864	100%	\$ 11,864	\$ -	\$ 11,864	100%
Interest Income	\$ 31,359	\$ 26,766	\$ 4,593	17%	2	\$ 205,061	\$ 138,647	\$ 66,414	48%	\$ 205,061	\$ 448,848	\$ (243,787)	-54%
Other Non-Transp Revenue	\$ 233	\$ -	\$ 233	100%		\$ 1,609	\$ 33,000	\$ (31,391)	-95%	\$ 1,609	\$ 65,106	\$ (63,497)	-98%
Sales Tax Revenue	\$ 1,639,000	\$ 1,739,890	\$ (100,890)	-6%	3	\$ 7,188,805	\$ 7,522,463	\$ (333,658)	-4%	\$ 7,188,805	\$ 7,449,040	\$ (260,235)	-3%
Transp Dev Act (TDA) - Op Asst	\$ -	\$ -	\$ -	0%		\$ 1,494,616	\$ 1,494,616	\$ -	0%	\$ 1,494,616	\$ 1,590,509	\$ (95,893)	-6%
Subtotal Other Revenue	\$ 1,691,571	\$ 1,785,582	\$ (94,011)	-5%		\$ 9,018,886	\$ 9,283,360	\$ (264,474)	-3%	\$ 9,018,886	\$ 9,731,853	\$ (712,967)	-7%
FTA Sec 5307 - Op Asst	\$ -	\$ -	\$ -	0%		\$ -	\$ -	\$ -	0%	\$ -	\$ 3,153,552	\$ (3,153,552)	-100%
Repay FTA Advance	\$ -	\$ -	\$ -	0%		\$ -	\$ -	\$ -	0%	\$ -	\$ -	\$ -	0%
FTA Sec 5311 - Rural Op Asst	\$ -	\$ -	\$ -	0%		\$ 161,615	\$ 161,615	\$ -	0%	\$ 161,615	\$ -	\$ 161,615	100%
Sec 5303 - AMBAG Funding	\$ -	\$ -	\$ -	0%		\$ -	\$ -	\$ -	0%	\$ -	\$ (3,169)	\$ 3,169	-100%
FTA Sec 5317 - Op Assistance	\$ -	\$ -	\$ -	0%		\$ -	\$ -	\$ -	0%	\$ -	\$ -	\$ -	0%
Subtotal Grant Revenue	\$ -	\$ -	\$ -	0%		\$ 161,615	\$ 161,615	\$ -	0%	\$ 161,615	\$ 3,150,383	\$ (2,988,768)	-95%
Subtotal Operating Revenue	\$ 2,437,526	\$ 2,480,133	\$ (42,607)	-2%		\$ 12,710,665	\$ 12,706,805	\$ 3,860	0%	\$ 12,710,665	\$ 15,880,612	\$ (3,169,947)	-20%
Total Operating Expenses	\$ 3,030,405					\$ 14,564,687				\$ 14,564,687	\$ 13,969,196		
Variance	\$ (592,879)					\$ (1,854,022)				\$ (1,854,022)	\$ 1,911,416		
One-Time Revenue													
Transfer (to)/from Capital Reserves	\$ -	\$ -	\$ -	0%		\$ -	\$ -	\$ -	0%	\$ -	\$ -	\$ -	0%
Transfer (to)/from Cash Flow Res	\$ -	\$ -	\$ -	0%		\$ -	\$ -	\$ -	0%	\$ -	\$ -	\$ -	0%
Transfer (to)/from W/C Reserve	\$ -	\$ -	\$ -	0%		\$ -	\$ -	\$ -	0%	\$ -	\$ -	\$ -	0%
Transfer (to)/from Liab/Ins Res	\$ -	\$ -	\$ -	0%		\$ -	\$ -	\$ -	0%	\$ -	\$ -	\$ -	0%
Carryover from Previous Year	\$ -	\$ -	\$ -	0%		\$ -	\$ -	\$ -	0%	\$ -	\$ -	\$ -	0%
Subtotal One-Time Revenue	\$ -	\$ -	\$ -	0%		\$ -	\$ -	\$ -	0%	\$ -	\$ -	\$ -	0%
Total Revenue	\$ 2,437,526	\$ 2,480,133	\$ (42,607)	-2%		\$ 12,710,665	\$ 12,706,805	\$ 3,860	0%	\$ 12,710,665	\$ 15,880,612	\$ (3,169,947)	-20%
Total Operating Expenses	\$ 3,030,405					\$ 14,564,687				\$ 14,564,687	\$ 13,969,196		
Variance	\$ (592,879)					\$ (1,854,022)				\$ (1,854,022)	\$ 1,911,416		

5-2.01

Attachment A



FY09
Operating Revenue
For the month ending - November 30, 2008

Percent of Year Elapsed - 42%

<u>Revenue Source</u>	<u>Actual</u>	<u>Current Period</u>				<u>Year to Date</u>				<u>YTD Year Over Year Comparison</u>				
		<u>Budget</u>	<u>\$ Var</u>	<u>% Var</u>	<u>Notes</u>	<u>Actual</u>	<u>Budget</u>	<u>\$ Var</u>	<u>% Var</u>	<u>Actual</u>	<u>FY08</u>	<u>\$ Var</u>	<u>% Var</u>	
										<u>FY09</u>				

Current Period Notes:

- 1) **Passenger Revenue** is over budget due to an increase in ridership.
- 2) **Interest Income** is over budget due to revenue budgeted using County Treasury estimates, while a higher interest rate was actually paid.
- 3) **Sales Tax Revenue** is under budget due to less consumer discretionary spending and current economic conditions.

5-2.2.2



FY09
Operating Expenses by Department
For the month ending - November 30, 2008

	Current Period				Notes	Year to Date				YTD Year Over Year Comparison			
	Actual	Budget	\$ Var	% Var		Actual	Budget	\$ Var	% Var	FY09 Actual	FY08	\$ Var	% Var
Departmental Personnel Expenses													
700 - SCCIC	\$ -	\$ -	\$ -	0%		\$ -	\$ -	\$ -	0%	\$ -	\$ -	\$ -	0%
1100 - Administration	\$ 62,432	\$ 90,510	\$ (28,078)	-31%		\$ 409,770	\$ 452,329	\$ (42,559)	-9%	\$ 409,770	\$ 369,138	\$ 40,632	11%
1200 - Finance	\$ 71,024	\$ 46,444	\$ 24,580	53%		\$ 257,138	\$ 232,137	\$ 25,001	11%	\$ 257,138	\$ 224,125	\$ 33,013	15%
1300 - Customer Service	\$ 33,908	\$ 37,321	\$ (3,413)	-9%		\$ 178,469	\$ 186,610	\$ (8,141)	-4%	\$ 178,469	\$ 166,435	\$ 12,034	7%
1400 - Human Resources	\$ 41,875	\$ 47,164	\$ (5,289)	-11%		\$ 229,006	\$ 235,735	\$ (6,729)	-3%	\$ 229,006	\$ 197,617	\$ 31,389	16%
1500 - Information Technology	\$ 38,675	\$ 41,293	\$ (2,618)	-6%		\$ 202,685	\$ 206,373	\$ (3,688)	-2%	\$ 202,685	\$ 201,078	\$ 1,607	1%
1700 - District Counsel	\$ 33,524	\$ 36,300	\$ (2,776)	-8%		\$ 171,994	\$ 181,432	\$ (9,438)	-5%	\$ 171,994	\$ 161,023	\$ 10,971	7%
1800 - Risk Management	\$ -	\$ -	\$ -	0%		\$ -	\$ -	\$ -	0%	\$ -	\$ -	\$ -	0%
2200 - Facilities Maintenance	\$ 77,515	\$ 82,015	\$ (4,500)	-5%		\$ 386,096	\$ 410,089	\$ (23,993)	-6%	\$ 386,096	\$ 351,022	\$ 35,074	10%
3100 - Paratransit Program	\$ 255,089	\$ 285,806	\$ (30,717)	-11%		\$ 1,234,670	\$ 1,429,028	\$ (194,458)	-14%	\$ 1,234,670	\$ 1,109,184	\$ 125,386	11%
3200 - Operations	\$ 148,494	\$ 177,921	\$ (29,427)	-17%		\$ 806,379	\$ 889,532	\$ (83,153)	-9%	\$ 806,379	\$ 802,236	\$ 4,143	1%
3300 - Bus Operators	\$ 1,123,112	\$ 1,122,781	\$ 331	0%		\$ 5,429,429	\$ 5,614,097	\$ (184,668)	-3%	\$ 5,429,429	\$ 5,085,864	\$ 343,565	7%
4100 - Fleet Maintenance	\$ 296,033	\$ 329,124	\$ (33,091)	-10%		\$ 1,552,029	\$ 1,688,474	\$ (136,445)	-8%	\$ 1,552,029	\$ 1,611,209	\$ (59,180)	-4%
9001 - Cobra Benefits	\$ 533	\$ -	\$ 533	100%		\$ 1,921	\$ -	\$ 1,921	100%	\$ 1,921	\$ 5,122	\$ (3,201)	-62%
9005 - Retired Employee Benefits	\$ 140,251	\$ 143,363	\$ (3,112)	-2%		\$ 629,873	\$ 716,815	\$ (86,942)	-12%	\$ 629,873	\$ 597,403	\$ 32,470	5%
9014 - Operating Grants	\$ -	\$ -	\$ -	0%		\$ -	\$ -	\$ -	0%	\$ -	\$ -	\$ -	0%
110020 - Operating Grants	\$ -	\$ -	\$ -	0%		\$ -	\$ -	\$ -	0%	\$ -	\$ -	\$ -	0%
100 - New Flyer Parts Credit	\$ -	\$ -	\$ -	0%		\$ -	\$ -	\$ -	0%	\$ -	\$ -	\$ -	0%
Subtotal Personnel Expenses	\$ 2,322,465	\$ 2,440,042	\$ (117,577)	-5%		\$ 11,489,359	\$ 12,242,651	\$ (753,292)	-6%	\$ 11,489,359	\$ 10,881,456	\$ 607,903	6%
Departmental Non-Personnel Expenses													
700 - SCCIC	\$ (0)	\$ 280	\$ (280)	-100%		\$ 20	\$ 300	\$ (280)	-93%	\$ 20	\$ 260	\$ (240)	-92%
1100 - Administration	\$ 15,865	\$ 33,461	\$ (17,596)	-53%		\$ 92,222	\$ 167,305	\$ (75,083)	-45%	\$ 92,222	\$ 280,238	\$ (188,016)	-67%
1200 - Finance	\$ 61,941	\$ 74,738	\$ (12,797)	-17%		\$ 327,506	\$ 386,784	\$ (59,278)	-15%	\$ 327,506	\$ 309,025	\$ 18,481	6%
1300 - Customer Service	\$ 13,273	\$ 13,824	\$ (551)	-4%		\$ 43,687	\$ 40,395	\$ 3,292	8%	\$ 43,687	\$ 25,094	\$ 18,593	74%
1400 - Human Resources	\$ 3,539	\$ 7,056	\$ (3,517)	-50%		\$ 14,208	\$ 35,280	\$ (21,072)	-60%	\$ 14,208	\$ 13,580	\$ 628	5%
1500 - Information Technology	\$ 7,266	\$ 9,222	\$ (1,956)	-21%		\$ 41,312	\$ 52,110	\$ (10,798)	-21%	\$ 41,312	\$ 67,343	\$ (26,031)	-39%
1700 - District Counsel	\$ 954	\$ 1,691	\$ (737)	-44%		\$ 5,618	\$ 8,455	\$ (2,837)	-34%	\$ 5,618	\$ 10,138	\$ (4,520)	-45%
1800 - Risk Management	\$ 1,735	\$ 20,833	\$ (19,098)	-92%		\$ 24,143	\$ 104,165	\$ (80,022)	-77%	\$ 24,143	\$ 13,090	\$ 11,053	84%
2200 - Facilities Maintenance	\$ 153,632	\$ 134,811	\$ 18,821	14%		\$ 690,914	\$ 695,559	\$ (4,645)	-1%	\$ 690,914	\$ 195,903	\$ 495,011	253%
3100 - Paratransit Program	\$ 90,951	\$ 65,910	\$ 25,041	38%		\$ 319,592	\$ 331,550	\$ (11,958)	-4%	\$ 319,592	\$ 363,702	\$ (44,110)	-12%
3200 - Operations	\$ 62,460	\$ 44,747	\$ 17,713	40%		\$ 266,262	\$ 218,485	\$ 47,777	22%	\$ 266,262	\$ 211,943	\$ 54,319	26%
3300 - Bus Operators	\$ -	\$ 334	\$ (334)	-100%		\$ 4,164	\$ 5,170	\$ (1,006)	-19%	\$ 4,164	\$ 4,793	\$ (629)	-13%
4100 - Fleet Maintenance	\$ 296,324	\$ 383,621	\$ (87,297)	-23%		\$ 1,233,836	\$ 1,918,101	\$ (684,265)	-36%	\$ 1,233,836	\$ 1,593,206	\$ (359,370)	-23%
9001 - Cobra Benefits	\$ -	\$ -	\$ -	0%		\$ -	\$ -	\$ -	0%	\$ -	\$ -	\$ -	0%
9005 - Retired Employee Benefits	\$ -	\$ -	\$ -	0%		\$ -	\$ -	\$ -	0%	\$ -	\$ -	\$ -	0%
9014 - Operating Grants	\$ -	\$ -	\$ -	0%		\$ 11,848	\$ -	\$ 11,848	100%	\$ 11,848	\$ (575)	\$ 12,423	-2161%
110020 - Operating Grants	\$ -	\$ -	\$ -	0%		\$ -	\$ -	\$ -	0%	\$ -	\$ -	\$ -	0%
100 - New Flyer Parts Credit	\$ -	\$ -	\$ -	0%		\$ 0	\$ -	\$ 0	100%	\$ 0	\$ -	\$ 0	100%
Subtotal Non-Personnel Expenses	\$ 707,940	\$ 790,528	\$ (82,588)	-10%		\$ 3,075,332	\$ 3,963,659	\$ (888,327)	-22%	\$ 3,075,332	\$ 3,087,740	\$ (12,408)	0%

5-2-08



FY09
Operating Expenses by Department
For the month ending - November 30, 2008

	Current Period					Year to Date				YTD Year Over Year Comparison			
	Actual	Budget	\$ Var	% Var	Notes	Actual	Budget	\$ Var	% Var	FY09 Actual	FY08	\$ Var	% Var
Total Departmental Expenses													
700 - SCCIC	\$ (0)	\$ 280	\$ (280)	-100%		\$ 20	\$ 300	\$ (280)	-93%	\$ 20	\$ 260	\$ (240)	-92%
1100 - Administration	\$ 78,297	\$ 123,971	\$ (45,674)	-37%	1	\$ 501,992	\$ 619,634	\$ (117,642)	-19%	\$ 501,992	\$ 649,376	\$ (147,384)	-23%
1200 - Finance	\$ 132,965	\$ 121,182	\$ 11,783	10%	2	\$ 584,644	\$ 618,921	\$ (34,277)	-6%	\$ 584,644	\$ 533,150	\$ 51,494	10%
1300 - Customer Service	\$ 47,181	\$ 51,145	\$ (3,964)	-8%		\$ 222,156	\$ 227,005	\$ (4,849)	-2%	\$ 222,156	\$ 191,529	\$ 30,627	16%
1400 - Human Resources	\$ 45,414	\$ 54,220	\$ (8,806)	-16%		\$ 243,214	\$ 271,015	\$ (27,801)	-10%	\$ 243,214	\$ 211,197	\$ 32,017	15%
1500 - Information Technology	\$ 45,941	\$ 50,515	\$ (4,574)	-9%		\$ 243,997	\$ 258,483	\$ (14,486)	-6%	\$ 243,997	\$ 268,421	\$ (24,424)	-9%
1700 - District Counsel	\$ 34,478	\$ 37,991	\$ (3,513)	-9%		\$ 177,612	\$ 189,887	\$ (12,275)	-6%	\$ 177,612	\$ 171,161	\$ 6,451	4%
1800 - Risk Management	\$ 1,735	\$ 20,833	\$ (19,098)	-92%	3	\$ 24,143	\$ 104,165	\$ (80,022)	-77%	\$ 24,143	\$ 13,090	\$ 11,053	84%
2200 - Facilities Maintenance	\$ 231,147	\$ 216,826	\$ 14,321	7%	4	\$ 1,077,010	\$ 1,105,648	\$ (28,638)	-3%	\$ 1,077,010	\$ 546,925	\$ 530,085	97%
3100 - Paratransit Program	\$ 346,040	\$ 351,716	\$ (5,676)	-2%		\$ 1,554,162	\$ 1,760,578	\$ (206,416)	-12%	\$ 1,554,162	\$ 1,472,866	\$ 81,276	6%
3200 - Operations	\$ 210,954	\$ 222,668	\$ (11,714)	-5%	5	\$ 1,072,641	\$ 1,108,017	\$ (35,376)	-3%	\$ 1,072,641	\$ 1,014,179	\$ 58,462	6%
3300 - Bus Operators	\$ 1,123,112	\$ 1,123,115	\$ (3)	0%		\$ 5,433,593	\$ 5,619,267	\$ (185,674)	-3%	\$ 5,433,593	\$ 5,090,657	\$ 342,936	7%
4100 - Fleet Maintenance	\$ 592,357	\$ 712,745	\$ (120,388)	-17%	6	\$ 2,785,865	\$ 3,606,575	\$ (820,710)	-23%	\$ 2,785,865	\$ 3,204,415	\$ (418,550)	-13%
9001 - Cobra Benefits	\$ 533	\$ -	\$ 533	100%		\$ 1,921	\$ -	\$ 1,921	100%	\$ 1,921	\$ 5,122	\$ (3,201)	-62%
9005 - Retired Employee Benefits	\$ 140,251	\$ 143,363	\$ (3,112)	-2%		\$ 629,873	\$ 716,815	\$ (86,942)	-12%	\$ 629,873	\$ 597,403	\$ 32,470	5%
9014 - Operating Grants	\$ -	\$ -	\$ -	0%		\$ 11,848	\$ -	\$ 11,848	100%	\$ 11,848	\$ (575)	\$ 12,423	-2161%
110020 - Operating Grants	\$ -	\$ -	\$ -	0%		\$ -	\$ -	\$ -	0%	\$ -	\$ -	\$ -	0%
100 - New Flyer Parts Credit	\$ -	\$ -	\$ -	0%		\$ 0	\$ -	\$ 0	100%	\$ 0	\$ -	\$ 0	100%
Total Operating Expenses	\$ 3,030,405	\$ 3,230,570	\$ (200,165)	-6%		\$ 14,564,691	\$ 16,206,310	\$ (1,641,619)	-10%	\$ 14,564,691	\$ 13,969,196	\$ 595,495	4%

** does not include depreciation

Current Period Notes:

- 1) **Administration** is under budget due to positions being moved to Finance and less than anticipated Prof & Tech Fees (web site redesign).
- 2) **Finance** is over budget due to added positions moved from Administration and Fleet Maintenance.
- 3) **Risk Management** is under budget due to below budgeted settlement costs paid in November 2008.
- 4) **Facilities Maintenance** is over budget due to SVT taxes paid in November 2008, while budgeted in October 2008.
- 5) **Operations** is under budget due to not being at full complement.
- 6) **Fleet** is under budget due to positions moved to Finance and less than anticipated fuel costs.

5-2.94



FY09
Consolidated Operating Expenses
For the month ending - November 30, 2008

	Current Period				Notes	Year to Date				YTD Year Over Year Comparison			
	Actual	Budget	\$ Var	% Var		Actual	Budget	\$ Var	% Var	FY09 Actual	FY08	\$ Var	% Var
LABOR													
501011 Bus Operator Pay	\$ 622,476	\$ 677,566	\$ (55,090)	-8%		\$ 3,268,188	\$ 3,387,830	\$ (119,642)	-4%	\$ 3,268,188	\$ 3,045,576	\$ 222,612	7%
501013 Bus Operator Overtime	\$ 140,475	\$ 114,459	\$ 26,016	23%		\$ 481,904	\$ 572,295	\$ (90,391)	-16%	\$ 481,904	\$ 518,125	\$ (36,221)	-7%
501021 Other Salaries	\$ 475,757	\$ 500,469	\$ (24,712)	-5%		\$ 2,550,272	\$ 2,545,257	\$ 5,015	0%	\$ 2,550,272	\$ 2,482,641	\$ 67,631	3%
501023 Other Overtime	\$ 19,249	\$ 24,661	\$ (5,412)	-22%		\$ 103,567	\$ 123,305	\$ (19,738)	-16%	\$ 103,567	\$ 120,327	\$ (16,760)	-14%
Total Labor -	\$ 1,257,957	\$ 1,317,155	\$ (59,198)	-4%		\$ 6,403,931	\$ 6,628,687	\$ (224,756)	-3%	\$ 6,403,931	\$ 6,166,669	\$ 237,262	4%
FRINGE BENEFITS													
502011 Medicare/Soc. Sec.	\$ 17,126	\$ 17,160	\$ (34)	0%		\$ 89,039	\$ 85,800	\$ 3,239	4%	\$ 89,039	\$ 84,426	\$ 4,613	5%
502021 Retirement	\$ 171,994	\$ 189,461	\$ (17,467)	-9%		\$ 925,629	\$ 947,305	\$ (21,676)	-2%	\$ 925,629	\$ 835,333	\$ 90,296	11%
502031 Medical Insurance	\$ 425,942	\$ 461,116	\$ (35,174)	-8%		\$ 2,057,225	\$ 2,305,580	\$ (248,355)	-11%	\$ 2,057,225	\$ 1,870,070	\$ 187,155	10%
502041 Dental Insurance	\$ 40,890	\$ 41,270	\$ (380)	-1%		\$ 198,468	\$ 206,350	\$ (7,882)	-4%	\$ 198,468	\$ 190,944	\$ 7,524	4%
502045 Vision Insurance	\$ 11,079	\$ 11,591	\$ (512)	-4%		\$ 55,477	\$ 57,955	\$ (2,478)	-4%	\$ 55,477	\$ 54,119	\$ 1,358	3%
502051 Life Insurance	\$ 69	\$ 4,163	\$ (4,094)	-98%		\$ 18,019	\$ 20,817	\$ (2,798)	-13%	\$ 18,019	\$ 16,096	\$ 1,923	12%
502060 State Disability	\$ 10,525	\$ 14,921	\$ (4,396)	-29%		\$ 56,373	\$ 74,605	\$ (18,232)	-24%	\$ 56,373	\$ 44,982	\$ 11,391	25%
502061 Disability Insurance	\$ 17,754	\$ 17,183	\$ 571	3%		\$ 88,414	\$ 85,915	\$ 2,499	3%	\$ 88,414	\$ 85,119	\$ 3,295	4%
502071 State Unemp. Ins.	\$ 86	\$ 373	\$ (287)	-77%		\$ 609	\$ 2,254	\$ (1,645)	-73%	\$ 609	\$ 2,455	\$ (1,846)	-75%
502081 Worker's Comp Ins.	\$ 174,500	\$ 91,592	\$ 82,908	91%		\$ 432,549	\$ 457,960	\$ (25,411)	-6%	\$ 432,549	\$ 384,797	\$ 47,752	12%
502083 Worker's Comp IBNR	\$ -	\$ -	\$ -	0%		\$ -	\$ -	\$ -	0%	\$ -	\$ -	\$ -	0%
502101 Holiday Pay	\$ 12,716	\$ 32,290	\$ (19,574)	-61%		\$ 74,330	\$ 161,452	\$ (87,122)	-54%	\$ 74,330	\$ 109,689	\$ (35,359)	-32%
502103 Floating Holiday	\$ 3,687	\$ 2,576	\$ 1,111	43%		\$ 8,206	\$ 12,020	\$ (3,814)	-32%	\$ 8,206	\$ 13,080	\$ (4,874)	-37%
502109 Sick Leave	\$ 46,586	\$ 72,390	\$ (25,804)	-36%		\$ 248,808	\$ 361,949	\$ (113,141)	-31%	\$ 248,808	\$ 235,219	\$ 13,589	6%
502111 Annual Leave	\$ 110,609	\$ 142,987	\$ (32,378)	-23%		\$ 748,221	\$ 714,935	\$ 33,286	5%	\$ 748,221	\$ 702,037	\$ 46,184	7%
502121 Other Paid Absence	\$ 12,113	\$ 11,824	\$ 289	2%		\$ 50,541	\$ 59,120	\$ (8,579)	-15%	\$ 50,541	\$ 41,395	\$ 9,146	22%
502251 Physical Exams	\$ 85	\$ 1,107	\$ (1,022)	-92%		\$ 1,755	\$ 5,534	\$ (3,779)	-68%	\$ 1,755	\$ 1,395	\$ 360	26%
502253 Driver Lic Renewal	\$ 98	\$ 363	\$ (265)	-73%		\$ 540	\$ 1,815	\$ (1,275)	-70%	\$ 540	\$ 644	\$ (104)	-16%
502999 Other Fringe Benefits	\$ 8,649	\$ 10,519	\$ (1,870)	-18%		\$ 31,224	\$ 52,595	\$ (21,371)	-41%	\$ 31,224	\$ 42,987	\$ (11,763)	-27%
Total Fringe Benefits -	\$ 1,064,508	\$ 1,122,886	\$ (58,378)	-5%		\$ 5,085,427	\$ 5,613,961	\$ (528,534)	-9%	\$ 5,085,427	\$ 4,714,787	\$ 370,640	8%
Total Personnel Expenses -	\$ 2,322,465	\$ 2,440,041	\$ (117,576)	-5%	1	\$ 11,489,358	\$ 12,242,648	\$ (753,290)	-6%	\$ 11,489,358	\$ 10,881,456	\$ 607,902	6%

5-2.05



FY09
Consolidated Operating Expenses
For the month ending - November 30, 2008

	Current Period					Year to Date				YTD Year Over Year Comparison			
	Actual	Budget	\$ Var	% Var	Notes	Actual	Budget	\$ Var	% Var	FY09 Actual	FY08	\$ Var	% Var
SERVICES													
503011 Acctg & Audit Fees	\$ 13,500	\$ 20,550	\$ (7,050)	-34%		\$ 40,200	\$ 48,050	\$ (7,850)	-16%	\$ 40,200	\$ 36,486	\$ 3,714	10%
503012 Admin & Bank Fees	\$ 233	\$ 1,380	\$ (1,147)	-83%		\$ 50,051	\$ 54,800	\$ (4,749)	-9%	\$ 50,051	\$ 44,387	\$ 5,664	13%
503031 Prof & Tech Fees	\$ 6,966	\$ 20,965	\$ (13,999)	-67%	2	\$ 46,853	\$ 119,571	\$ (72,718)	-61%	\$ 46,853	\$ 71,471	\$ (24,618)	-34%
503032 Legislative Services	\$ 7,500	\$ 8,367	\$ (867)	-10%		\$ 37,500	\$ 41,835	\$ (4,335)	-10%	\$ 37,500	\$ 37,970	\$ (470)	-1%
503033 Legal Services	\$ -	\$ 4,583	\$ (4,583)	-100%		\$ -	\$ 22,915	\$ (22,915)	-100%	\$ -	\$ 74	\$ (74)	-100%
503034 Pre-Employ. Exams	\$ 1,605	\$ 1,180	\$ 425	36%		\$ 4,457	\$ 5,900	\$ (1,443)	-24%	\$ 4,457	\$ 4,807	\$ (350)	-7%
503041 Temp Help	\$ 13,051	\$ -	\$ 13,051	100%	3	\$ 64,271	\$ -	\$ 64,271	100%	\$ 64,271	\$ 55,010	\$ 9,261	17%
503161 Custodial Services	\$ 5,072	\$ 5,642	\$ (570)	-10%		\$ 28,256	\$ 28,210	\$ 46	0%	\$ 28,256	\$ 27,649	\$ 607	2%
503162 Uniform & Laundry	\$ 2,233	\$ 3,629	\$ (1,396)	-38%		\$ 16,400	\$ 18,145	\$ (1,745)	-10%	\$ 16,400	\$ 16,943	\$ (543)	-3%
503171 Security Services	\$ 46,292	\$ 34,083	\$ 12,209	36%	4	\$ 164,269	\$ 170,415	\$ (6,146)	-4%	\$ 164,269	\$ 137,331	\$ 26,938	20%
503221 Classified/Legal Ads	\$ 1,003	\$ 2,475	\$ (1,472)	-59%		\$ 6,744	\$ 12,375	\$ (5,631)	-46%	\$ 6,744	\$ 5,787	\$ 957	17%
503222 Legal Advertising	\$ -	\$ -	\$ -	0%		\$ -	\$ -	\$ -	0%	\$ -	\$ -	\$ -	0%
503225 Graphic Services	\$ -	\$ 417	\$ (417)	-100%		\$ -	\$ 2,085	\$ (2,085)	-100%	\$ -	\$ -	\$ -	0%
503351 Repair - Bldg & Impr	\$ 10,919	\$ 7,500	\$ 3,419	46%		\$ 41,571	\$ 37,500	\$ 4,071	11%	\$ 41,571	\$ 32,979	\$ 8,592	26%
503352 Repair - Equipment	\$ 27,558	\$ 39,037	\$ (11,479)	-29%		\$ 137,451	\$ 197,185	\$ (59,734)	-30%	\$ 137,451	\$ 60,599	\$ 76,852	127%
503353 Repair - Rev Vehicle	\$ 41,851	\$ 30,000	\$ 11,851	40%	5	\$ 228,022	\$ 150,000	\$ 78,022	52%	\$ 228,022	\$ 133,770	\$ 94,252	70%
503354 Repair - Non Rev Vehicle	\$ 347	\$ 2,500	\$ (2,153)	-86%		\$ 10,884	\$ 12,500	\$ (1,616)	-13%	\$ 10,884	\$ 9,075	\$ 1,809	20%
503363 Haz. Mat Disposal	\$ 2,783	\$ 2,517	\$ 266	11%		\$ 18,552	\$ 12,582	\$ 5,970	47%	\$ 18,552	\$ 11,752	\$ 6,800	58%
Total Services -	\$ 180,913	\$ 184,825	\$ (3,912)	-2%		\$ 895,481	\$ 934,068	\$ (38,587)	-4%	\$ 895,481	\$ 686,090	\$ 209,391	31%
MOBILE MATERIALS AND SUPPLIES													
504011 Fuels & Lube Non Rev Veh	\$ 12,335	\$ 16,417	\$ (4,082)	-25%		\$ 79,398	\$ 82,085	\$ (2,687)	-3%	\$ 79,398	\$ 62,695	\$ 16,703	27%
504012 Fuels & Lube Rev Veh	\$ 133,841	\$ 262,500	\$ (128,659)	-49%	6	\$ 788,572	\$ 1,312,500	\$ (523,928)	-40%	\$ 788,572	\$ 921,548	\$ (132,976)	-14%
504021 Tires & Tubes	\$ 16,336	\$ 17,083	\$ (747)	-4%		\$ 104,718	\$ 85,415	\$ 19,303	23%	\$ 104,718	\$ 80,765	\$ 23,953	30%
504161 Other Mobile Supplies	\$ 284	\$ 833	\$ (549)	-66%		\$ 4,362	\$ 4,165	\$ 197	5%	\$ 4,362	\$ 1,443	\$ 2,919	202%
504191 Rev Vehicle Parts	\$ 99,210	\$ 64,750	\$ 34,460	53%	7	\$ 115,572	\$ 323,750	\$ (208,178)	-64%	\$ 115,572	\$ 302,090	\$ (186,518)	-62%
Total Mobile Materials & Supplies -	\$ 262,006	\$ 361,583	\$ (99,577)	-28%		\$ 1,092,622	\$ 1,807,915	\$ (715,293)	-40%	\$ 1,092,622	\$ 1,368,541	\$ (275,919)	-20%

5-2-06



FY09
Consolidated Operating Expenses
For the month ending - November 30, 2008

	Current Period					Year to Date				YTD Year Over Year Comparison			
	Actual	Budget	\$ Var	% Var	Notes	Actual	Budget	\$ Var	% Var	FY09 Actual	FY08	\$ Var	% Var
<u>OTHER MATERIALS & SUPPLIES</u>													
504205 Freight Out	\$ 166	\$ 292	\$ (126)	-43%		\$ 1,161	\$ 1,460	\$ (299)	-20%	\$ 1,161	\$ 1,218	\$ (57)	-5%
504211 Postage & Mailing	\$ 63	\$ 1,720	\$ (1,657)	-96%		\$ 4,084	\$ 8,600	\$ (4,516)	-53%	\$ 4,084	\$ 5,004	\$ (920)	-18%
504214 Promotional Items	\$ -	\$ -	\$ -	0%		\$ -	\$ -	\$ -	0%	\$ -	\$ -	\$ -	0%
504215 Printing	\$ 11,056	\$ 12,900	\$ (1,844)	-14%		\$ 36,821	\$ 37,000	\$ (179)	0%	\$ 36,821	\$ 18,394	\$ 20,427	125%
504217 Photo Supply/Processing	\$ 958	\$ 808	\$ 150	19%		\$ 4,175	\$ 4,040	\$ 135	3%	\$ 4,175	\$ 1,402	\$ 2,773	198%
504311 Office Supplies	\$ 5,216	\$ 7,455	\$ (2,239)	-30%		\$ 33,827	\$ 37,275	\$ (3,448)	-9%	\$ 33,827	\$ 40,341	\$ (6,514)	-16%
504315 Safety Supplies	\$ 318	\$ 2,692	\$ (2,374)	-88%		\$ 8,157	\$ 13,460	\$ (5,303)	-39%	\$ 8,157	\$ 15,458	\$ (7,301)	-47%
504317 Cleaning Supplies	\$ 4,984	\$ 4,500	\$ 484	11%		\$ 18,840	\$ 22,500	\$ (3,660)	-17%	\$ 18,840	\$ 20,934	\$ (2,094)	-11%
504409 Repair/Maint Supplies	\$ 4,347	\$ 3,833	\$ 514	13%		\$ 28,999	\$ 19,165	\$ 9,834	51%	\$ 28,999	\$ 18,812	\$ 10,187	54%
504421 Non-Inventory Parts	\$ 9,179	\$ 3,500	\$ 5,679	162%	8	\$ 34,822	\$ 20,000	\$ 14,822	74%	\$ 34,822	\$ 19,533	\$ 15,289	78%
504511 Small Tools	\$ 479	\$ 833	\$ (354)	-42%		\$ 3,147	\$ 4,165	\$ (1,018)	-24%	\$ 3,147	\$ 5,043	\$ (1,896)	-38%
504515 Employee Tool Rplcmt	\$ 417	\$ 217	\$ 200	92%		\$ 922	\$ 1,085	\$ (163)	-15%	\$ 922	\$ 509	\$ 413	81%
Total Other Materials & Supplies -	\$ 37,183	\$ 38,750	\$ (1,567)	-4%		\$ 174,755	\$ 168,750	\$ 6,005	4%	\$ 174,755	\$ 144,648	\$ 30,107	21%
<u>UTILITIES</u>													
505011 Gas & Electric	\$ 15,050	\$ 18,418	\$ (3,368)	-18%		\$ 77,279	\$ 92,089	\$ (14,810)	-16%	\$ 77,279	\$ 82,234	\$ (4,955)	-6%
505021 Water & Garbage	\$ 12,355	\$ 10,313	\$ 2,042	20%		\$ 57,470	\$ 51,565	\$ 5,905	11%	\$ 57,470	\$ 51,670	\$ 5,800	11%
505031 Telecommunications	\$ 7,147	\$ 10,025	\$ (2,878)	-29%		\$ 39,381	\$ 50,126	\$ (10,745)	-21%	\$ 39,381	\$ 34,930	\$ 4,451	13%
Total Utilities -	\$ 34,552	\$ 38,756	\$ (4,204)	-11%		\$ 174,130	\$ 193,780	\$ (19,650)	-10%	\$ 174,130	\$ 168,834	\$ 5,296	3%
<u>CASUALTY & LIABILITY</u>													
506011 Insurance - Property	\$ 5,912	\$ 9,862	\$ (3,950)	-40%		\$ 29,560	\$ 49,310	\$ (19,750)	-40%	\$ 29,560	\$ 16,021	\$ 13,539	85%
506015 Insurance - PL & PD	\$ 40,526	\$ 42,500	\$ (1,974)	-5%		\$ 202,630	\$ 212,500	\$ (9,870)	-5%	\$ 202,630	\$ 171,809	\$ 30,821	18%
506021 Insurance - Other	\$ -	\$ -	\$ -	0%		\$ 711	\$ 801	\$ (90)	-11%	\$ 711	\$ 1,007	\$ (296)	-29%
506123 Settlement Costs	\$ 1,143	\$ 12,500	\$ (11,357)	-91%	9	\$ 23,041	\$ 62,500	\$ (39,459)	-63%	\$ 23,041	\$ 12,786	\$ 10,255	80%
506127 Repairs - Dist Prop	\$ 1,391	\$ -	\$ 1,391	100%		\$ (21,452)	\$ -	\$ (21,452)	100%	\$ (21,452)	\$ (6,460)	\$ (14,992)	232%
Total Casualty & Liability -	\$ 48,972	\$ 64,862	\$ (15,890)	-24%		\$ 234,490	\$ 325,111	\$ (90,621)	-28%	\$ 234,490	\$ 195,163	\$ 39,327	20%
<u>TAXES</u>													
507051 Fuel Tax	\$ 783	\$ 917	\$ (134)	-15%		\$ 2,921	\$ 4,584	\$ (1,663)	-36%	\$ 2,921	\$ 3,809	\$ (888)	-23%
507201 Licenses & permits	\$ 1,933	\$ 2,012	\$ (79)	-4%		\$ 4,330	\$ 6,463	\$ (2,133)	-33%	\$ 4,330	\$ 4,106	\$ 224	5%
507999 Other Taxes	\$ 17,068	\$ 500	\$ 16,568	3314%	10	\$ 20,403	\$ 21,500	\$ (1,097)	-5%	\$ 20,403	\$ 12,035	\$ 8,368	70%
Total Utilities -	\$ 19,784	\$ 3,429	\$ 16,355	477%		\$ 27,654	\$ 32,547	\$ (4,893)	-15%	\$ 27,654	\$ 19,950	\$ 7,704	39%

5-2.07



FY09
Consolidated Operating Expenses
For the month ending - November 30, 2008

	Current Period					Year to Date					YTD Year Over Year Comparison			
	Actual	Budget	\$ Var	% Var	Notes	Actual	Budget	\$ Var	% Var	FY09 Actual	FY08	\$ Var	% Var	
<u>PURCHASED TRANSPORTATION</u>														
503406 Contr/Paratrans	\$ 55,587	\$ 20,833	\$ 34,754	167%	11	\$ 109,073	\$ 104,165	\$ 4,908	5%	\$ 109,073	\$ 159,352	\$ (50,279)	-32%	
Total Purchased Transportation -	\$ 55,587	\$ 20,833	\$ 34,754	167%		\$ 109,073	\$ 104,165	\$ 4,908	5%	\$ 109,073	\$ 159,352	\$ (50,279)	-32%	
<u>MISC</u>														
509011 Dues & Subscriptions	\$ 4,787	\$ 5,355	\$ (568)	-11%		\$ 26,376	\$ 26,775	\$ (399)	-1%	\$ 26,376	\$ 9,167	\$ 17,209	188%	
509085 Advertising - Rev Product	\$ -	\$ -	\$ -	0%		\$ -	\$ -	\$ -	0%	\$ -	\$ -	\$ -	0%	
509101 Emp Incentive Prog	\$ 350	\$ 1,109	\$ (759)	-68%		\$ 4,094	\$ 9,045	\$ (4,951)	-55%	\$ 4,094	\$ 4,050	\$ 44	1%	
509121 Employee Training	\$ 1,718	\$ 2,492	\$ (774)	-31%		\$ 12,999	\$ 18,460	\$ (5,461)	-30%	\$ 12,999	\$ 12,584	\$ 415	3%	
509123 Travel	\$ 1,729	\$ 6,003	\$ (4,274)	-71%		\$ 18,590	\$ 30,013	\$ (11,423)	-38%	\$ 18,590	\$ 13,386	\$ 5,204	39%	
509125 Local Meeting Exp	\$ 175	\$ 390	\$ (215)	-55%		\$ 1,172	\$ 1,950	\$ (778)	-40%	\$ 1,172	\$ 1,381	\$ (209)	-15%	
509127 Board Director Fees	\$ 1,000	\$ 1,100	\$ (100)	-9%		\$ 4,550	\$ 5,500	\$ (950)	-17%	\$ 4,550	\$ 5,750	\$ (1,200)	-21%	
509150 Contributions	\$ -	\$ 54	\$ (54)	-100%		\$ -	\$ 270	\$ (270)	-100%	\$ -	\$ 98	\$ (98)	-100%	
509197 Sales Tax Expense	\$ -	\$ -	\$ -	0%		\$ -	\$ -	\$ -	0%	\$ -	\$ -	\$ -	0%	
509198 Cash Over/Short	\$ (33)	\$ 42	\$ (75)	-179%		\$ (266)	\$ 210	\$ (476)	-227%	\$ (266)	\$ 72	\$ (338)	-469%	
Total Misc -	\$ 9,726	\$ 16,545	\$ (6,819)	-41%		\$ 67,515	\$ 92,223	\$ (24,708)	-27%	\$ 67,515	\$ 46,488	\$ 21,027	45%	
<u>LEASES & RENTALS</u>														
512011 Facility Rentals	\$ 58,533	\$ 58,721	\$ (188)	0%		\$ 292,664	\$ 293,606	\$ (942)	0%	\$ 292,664	\$ 288,677	\$ 3,987	1%	
512061 Equipment Rentals	\$ 684	\$ 2,225	\$ (1,541)	-69%		\$ 6,945	\$ 11,500	\$ (4,555)	-40%	\$ 6,945	\$ 9,997	\$ (3,052)	-31%	
Total Leases & Rentals -	\$ 59,217	\$ 60,946	\$ (1,729)	-3%		\$ 299,609	\$ 305,106	\$ (5,497)	-2%	\$ 299,609	\$ 298,674	\$ 935	0%	
Total Non-Personnel Expenses -	\$ 707,940	\$ 790,529	\$ (82,589)	-10%		\$ 3,075,329	\$ 3,963,665	\$ (888,336)	-22%	\$ 3,075,329	\$ 3,087,740	\$ (12,411)	0%	
TOTAL OPERATING EXPENSE -	\$ 3,030,405	\$ 3,230,570	\$ (200,165)	-6%		\$ 14,564,687	\$ 16,206,313	\$ (1,641,626)	-10%	\$ 14,564,687	\$ 13,969,196	\$ 595,491	4%	

** does not include depreciation

Current Period Notes:

- 1) **Total Personnel Expenses** are below budget due to not being at full complement, and lower than anticipated medical costs.
- 2) **Prof & Tech Fees** are below budget due to anticipated website redesign costs straight-lined.
- 3) **Temp Help** is over budget due to vacancies and work loads.

5-2-08



FY09
Consolidated Operating Expenses
For the month ending - November 30, 2008

	Current Period					Year to Date				YTD Year Over Year Comparison			
	<u>Actual</u>	<u>Budget</u>	<u>\$ Var</u>	<u>% Var</u>	<u>Notes</u>	<u>Actual</u>	<u>Budget</u>	<u>\$ Var</u>	<u>% Var</u>	<u>FY09</u>	<u>FY08</u>	<u>\$ Var</u>	<u>% Var</u>
4) Security Services	are over budget due to accruals and actual invoices posted in the month of November. Accruals will be reversed in December.												
5) Repair - Rev Vehicle	is over budget due to an aging fleet that requires increased repairs. Budget increase requested at December 19 Board meeting.												
6) Fuels & Lube Rev Veh	is under budget due to the CNG conversion and the resulting economies in fuel consumption.												
7) Rev Veh Parts	is over budget due to the monthly acquisition of parts using the New Flyer Parts Credit.												
8) Non-Inventory Parts	is over budget due to initial setup for new fastener vendor - Kimball Midwest for Fleet. Budget increase requested at December 19 Board Meeting.												
9) Settlement costs	are under budget due to less than anticipated settlement costs for the month.												
10) Other Taxes	is over budget due to SVT related taxes paid in November.												
11) Contr/Paratrans	is over budget. More than budgeted rides were needed for the month.												

5-2.09



**FY2009
CAPITAL BUDGET**

For the month ending - November 30, 2008

	<u>YTD Actual</u>	<u>FY09 Budget</u>	<u>Remaining Budget</u>	<u>% Spent YTD</u>
<u>Grant-Funded Projects</u>				
MetroBase Maintenance Facility	\$ 1,700,953	\$ 3,605,404	\$ 1,904,451	47%
MetroBase Operations Facility	\$ -	\$ 9,404,019	\$ 9,404,019	0%
Local Bus Replacement	\$ 3,561,384	\$ 3,572,932	\$ 11,548	100%
CNG Bus Conversions	\$ 1,382,989	\$ 3,410,000	\$ 2,027,011	41%
Pacific Station Project	\$ 2,983	\$ 3,190,300	\$ 3,187,317	0%
H17 Bus Replacement	\$ 2,351,425	\$ 2,359,050	\$ 7,625	100%
Advanced Traveller Information System	\$ -	\$ 500,000	\$ 500,000	0%
Facility Camera Security System	\$ -	\$ 220,000	\$ 220,000	0%
Bus Camera Project	\$ -	\$ 205,000	\$ 205,000	0%
Trapeze Pass Interactive Voice Response System	\$ -	\$ 91,141	\$ 91,141	0%
Replace Dispatch Console	\$ 18,048	\$ 25,000	\$ 6,952	72%
Subtotal Grant Funded Projects	\$ 9,017,782	\$ 26,582,846	\$ 17,565,064	34%
<u>District Funded Projects</u>				
<u>IT Projects</u>				
Replace Fleet & Facilities Maintenance Software	\$ -	\$ 470,000	\$ 470,000	0%
Upgrade District Phone System	\$ -	\$ 100,000	\$ 100,000	0%
GFI Data Warehouse Project: Phase I	\$ -	\$ 65,000	\$ 65,000	0%
Replace 4 Windows and 1 Sun Server	\$ 49,496	\$ 50,000	\$ 504	99%
Trapeze Pass Customer Certification Software	\$ -	\$ 46,000	\$ 46,000	0%
ATP - Hastus Run Time Analysis Program - IT/OPS	\$ 18,695	\$ 19,264	\$ 569	97%
Upgrade GFI software to System 7 Version 2	\$ -	\$ 17,000	\$ 17,000	0%
(2) Laptops (1) IT (1) Financial Analyst	\$ -	\$ 4,500	\$ 4,500	0%
FMLA Tracking Software	\$ -	\$ 4,000	\$ 4,000	0%
Portable Projector w/case	\$ -	\$ 2,000	\$ 2,000	0%
<u>Facilities Repair & Improvements</u>				
Bus Stop Improvements	\$ -	\$ 179,900	\$ 179,900	0%
Passenger Waiting Shelters - LNI (10)	\$ -	\$ 70,000	\$ 70,000	0%
Replace Roof - Watsonville Transit Center Main Building	\$ -	\$ 50,000	\$ 50,000	0%
Patch, Reseal, and Restripe - Greyhound Lot	\$ -	\$ 21,390	\$ 21,390	0%
Digital ID Card Processing Equipment	\$ -	\$ 17,000	\$ 17,000	0%
Fencing - Service Bldg. 1200B River St.	\$ -	\$ 16,000	\$ 16,000	0%
Patch, Reseal, Restripe - Cavallaro Transit Center (SVT)	\$ -	\$ 7,550	\$ 7,550	0%
Patch, Reseal, Restripe - Soquel Park & Ride Lot	\$ -	\$ 5,650	\$ 5,650	0%
Reseal Operations Facility Roof-FY08 - Retention Invoice	\$ 2,663	\$ -	\$ (2,663)	100%
Add Alarm Audio/Visual - OPS Bldg	\$ 1,744	\$ -	\$ (1,744)	100%
Spare Posi/Lock - 105 Nozzle Assembly	\$ -	\$ 1,208	\$ 1,208	0%

5-2.910



**FY2009
CAPITAL BUDGET**

For the month ending - November 30, 2008

	<u>YTD Actual</u>		<u>FY09 Budget</u>		<u>Remaining Budget</u>		<u>% Spent YTD</u>
<u>Revenue Vehicle Replacement</u>							
ParaCruz Van - Replacements (27)	\$ -	\$	2,840,804	\$	2,840,804		0%
ParaCruz Van - Expansion (3)	\$ -	\$	300,000	\$	300,000		0%
Rebuild Bus Engines - 1998 Fleet	\$ 115,495	\$	106,302	\$	(9,193)		109%
<u>Non-Revenue Vehicle Replacement</u>							
Supervisor Vehicle - Hybrid	\$ -	\$	29,500	\$	29,500		0%
DGS Fees - Last FY Purchase	\$ 1,651	\$	-	\$	(1,651)		100%
<u>Maint Equipment</u>							
Replace Repeater for Davenport	\$ -	\$	15,000	\$	15,000		0%
Portable Steam Cleaner - Transit Center cleaning	\$ -	\$	11,207	\$	11,207		0%
Battery Powered Walk Behind Sweeper - Pacific Station	\$ -	\$	5,500	\$	5,500		0%
Wet/Dry Vac - Pacific Station, & other Metro facilities	\$ -	\$	1,400	\$	1,400		0%
Decelerometer w/Printer	\$ -	\$	1,323	\$	1,323		0%
2000 Watt Generator	\$ -	\$	1,200	\$	1,200		0%
<u>Office Equipment</u>							
Digital Cameras - Supervisors (12)	\$ -	\$	3,500	\$	3,500		100%
<u>Admin</u>							
Purchase & Renovation of Vernon Bldg	\$ 19,792	\$	2,962,139	\$	2,942,347		1%
<hr/>							
Subtotal District Funded Projects	\$ 209,536	\$	7,424,337	\$	7,214,801		3%
<hr/>							
TOTAL CAPITAL PROJECTS	\$ 9,227,317	\$	34,007,183	\$	24,779,865		27%

5-2.2.11



**FY2009
CAPITAL BUDGET**

For the month ending - November 30, 2008

	<u>YTD Actual</u>	<u>FY09 Budget</u>	<u>Remaining Budget</u>	<u>% Spent YTD</u>
<u>CAPITAL FUNDING</u>				
Federal Capital Grants	\$ 752,084	\$ 2,668,343	\$ 1,916,258	28%
State/Other Capital Grants (STIP)	\$ 6,582,989	\$ 8,610,000	\$ 2,027,011	76%
State/Other Capital Grants (1B PTMISEA)	\$ 538,102	\$ 4,404,019	\$ 3,865,917	12%
State/Other Capital Grants (TCRP)	\$ 2,983	\$ 873,216	\$ 870,233	0%
State/Other Capital Grants	\$ -	\$ 500,000	\$ 500,000	0%
State Security Bond Funds (1B)	\$ 18,048	\$ 440,505	\$ 422,457	4%
STA Funding (Current Year) *	\$ -	\$ 4,918,675	\$ 4,918,675	0%
STA Funding (Prior Year)	\$ 460,344	\$ 574,325	\$ 113,981	80%
Alternative Fuel Conversion Fund	\$ 462,000	\$ 462,000	\$ -	100%
District Reserves (Lawsuit & Sakata Proceeds)	\$ 410,768	\$ 6,440,577	\$ 6,029,809	6%
Capital Reserves	\$ -	\$ 4,115,523	\$ 4,115,523	0%
TOTAL CAPITAL FUNDING	\$ 9,227,317	\$ 34,007,183	\$ 24,779,865	27%

* Based on FY09 STA Claim of \$5,340,804

5-2.912



AGENDA

**JANUARY 21, 2009 - 6:00 PM
PACIFIC STATION CONFERENCE ROOM
920 PACIFIC AVENUE, SANTA CRUZ, CALIFORNIA**

- 1. ROLL CALL**
- 2. AGENDA ADDITIONS/DELETIONS**
- 3. ORAL/WRITTEN COMMUNICATION**
- 4. CONSIDERATION OF APPROVAL OF MINUTES OF DECEMBER 17, 2008**
- 5. ACCEPT RIDERSHIP REPORT FOR OCTOBER 2008**
- 6. FILE PARACRUZ OPERATIONS STATUS REPORT FOR SEPTEMBER 2008**
- 7. CONSIDERATION OF PASSENGER LOADING AND UNLOADING ZONE AT THE WATSONVILLE TRANSIT CENTER**
- 8. REPORT BY MAC REPRESENTATIVE TO OTHER TRANSIT RELATED MEETINGS**
- 9. CONSIDERATION OF FIXED ROUTE HOLIDAY SERVICE**
- 10. CONSIDERATION OF PUBLISHED BUS SCHEDULES AND ABILITY OF METRO'S FIXED ROUTE TO STAY "ON TIME" AND MAKE CONNECTIONS**
- 11. BUS OPERATOR SHIFTS**
- 12. CONSIDERATION OF REGULAR MEETING MAC CALENDAR FOR 2009**
- 13. DISTRIBUTION OF MAC VOUCHERS**
- 14. COMMUNICATIONS TO METRO GENERAL MANAGER**
- 15. COMMUNICATIONS TO METRO BOARD OF DIRECTORS**
- 16. ITEMS FOR NEXT MEETING AGENDA**
- 17. ADJOURNMENT**

*NEXT MEETING: WEDNESDAY, FEBRUARY 18, 2009, AT 6:00 PM
PACIFIC STATION CONFERENCE ROOM*

5-4.1

SANTA CRUZ METROPOLITAN TRANSIT DISTRICT

Minutes - METRO Advisory Committee (MAC)

November 19, 2008

The METRO Advisory Committee (MAC) met on Wednesday, November 19, 2008 in the Pacific Station Conference Room located at 920 Pacific Avenue in Santa Cruz, California.

Chair Naomi Gunther called the meeting to order at 6:08 p.m.

1. ROLL CALL:

MEMBERS PRESENT

Naomi Gunther, Chair
Heidi Curry
Mara Murphy, Vice Chair
Dennis "Pop" Papadopulo
Dave Williams
Robert Yount

MEMBERS ABSENT

Stuart Rosenstein

VISITORS PRESENT

Donald Hagen, Board Member
Pat Piras, ADA Consultant
Karena Pushnik, SCCRTC

STAFF PRESENT

Ciro Aguirre, Operations Manager
Mary Ferrick, Fixed Route Superintendent
April Warnock, Paratransit Superintendent

2. AGENDA ADDITIONS/DELETIONS

None.

3. ORAL/WRITTEN COMMUNICATION

Written:

None.

Oral:

Donald Hagen suggested that riders could pay two installments of \$25.00 for their monthly pass instead of a full payment of \$50.00 due to hard economic times and said he would like MAC's perspective on the idea and thought maybe they could make a recommendation to the Board of Directors.

Robert Yount suggested that a few MAC members and Board members go on a local radio show to promote MAC membership, encourage the public to come to MAC meetings and provide information about METRO.

Mr. Yount also expressed his extreme frustration with cigarette smokers at bus stops on West Cliff Drive.

5-4.2

4. CONSIDERATION OF MINUTES OF OCTOBER 15, 2008

ACTION: MOTION: DAVE WILLIAMS SECOND: ROBERT YOUNT

ACCEPT AND FILE MINUTES OF THE OCTOBER 15, 2008 MEETING AS PRESENTED.

Motion passed unanimously with Stuart Rosenstein being absent.

5. RIDERSHIP REPORT FOR JULY 2008 AND AUGUST 2008

Robert Yount asked if ridership has started to drop off due to declining gas prices? Ciro Aguirre answered that ridership is up by 33% and that he believes the economic situation has caused people to rethink their spending habits and view the bus as a viable option for transportation.

Chair Naomi Gunther wanted to know if there were any pass-bys on the Highway 17 Express. Ciro Aguirre replied that METRO is experiencing a large ridership and there are more standees, but there weren't any pass-bys. Mr. Aguirre reported that METRO recently purchased 5 new buses that are expected to be in service by the middle of December and that METRO is keeping 7 older buses that had been scheduled to be retired. Mr. Aguirre also mentioned METRO had reached the 700,000 passenger mark for this fiscal year.

Chair Naomi Gunther stated that she thinks METRO should highlight achievements like this one and communicate them to the community. Ciro Aguirre said there is a fact area on the website that can be updated with this type of information.

6. PARACRUZ OPERATIONS STATUS REPORT FOR JULY 2008

April Warnock reported that the July 2008 "Percent in the Ready Window" listed on page 2 of the Staff Report should be 94.44%. Robert Yount suggested that ParaCruz staff be commended for their accomplishments.

Robert Yount asked where the figures for the Performance Goals on page 3 of the Staff Report came from? April Warnock stated the Board had requested this information and this was the first time that the goals have been included in the report. Most figures were taken from the old RFP for Community Bridges as a starting point and will need to be updated for METRO.

Vice Chair Mara Murphy asked how strict ParaCruz is about a second rescheduled ride and if they drop people from the service? April Warnock said ParaCruz has not dropped anyone and explained the rescheduled ride process. Dennis Papadopulo asked if ParaCruz still had the 5-minute wait procedure? April Warnock said yes and she and Ciro Aguirre explained the process used to initiate the 5-minute wait and explained that it actually involves additional minutes.

Vice Chair Mara Murphy stated that she feels that the drivers should be consistent with policies and procedures. Ciro Aguirre explained that operators become familiar with their passengers' needs and some may provide an extra level of helpful service as a courtesy.

7. CONSIDERATION OF WHETHER METRO SHOULD ALLOW PARACRUZ ELIGIBLE RIDERS FREE FARES ON METRO'S FIXED ROUTE

Karena Pushnik distributed a cursory survey of other transit agencies that was conducted by E&D TAC, which is attached to the file copy of these minutes. METRO received E&D TAC's input on this issue through discussions related to the revisions of the Discount Fare Policy and it was recommended that METRO pursue a policy that would allow ParaCruz riders free fares on fixed route transit as a way of reducing ParaCruz costs.

Chair Naomi Gunther asked the amount of fare for ParaCruz and fixed route rides? April Warnock replied ParaCruz is \$3.00, Fixed Route is \$1.50, and the Senior/Disabled fare is \$.75.

Dave Williams suggested that for a defined period of time ParaCruz drivers could give every passenger they transport a free fixed route ride coupon and see what the results are. Robert Yount agreed that is a good idea. Pat Piras said METRO would need some way of tracking the fixed route coupons because the ParaCruz rider could give them to anyone to ride the bus for free.

Vice Chair Mara Murphy asked how much money METRO would save or how many ParaCruz riders might be using fixed route? April Warnock said that although ParaCruz has a great tracking system due to the nature of the business, currently there is no tracking for fixed route.

Pat Piras said most of the transit systems in LA County allow a free fare to their paratransit riders, because they have a very rigorous eligibility process. Other transit systems that have set up the free fare have done it under very good economic times. Ms. Piras pointed out that if anyone that has a paratransit I. D. is allowed to use fixed route for free, it creates a rush of people applying for paratransit eligibility solely to get free rides on fixed route. This also creates the potential of increased appeals and METRO currently has a really good system in place with very few appeals.

Vice Chair Mara Murphy said that education should be provided on how to ride the bus to build their comfort level. April Warnock said METRO has a fixed route Accessible Services Coordinator that provides free mobility training to seniors and disabled people of all ages.

Pat Piras explained how there could be abuses under the current eligibility determination process and that replacing the current software with a module linked to the scheduling program will make the information more readily available to reservations staff.

MAC members said that in order to understand the impact, the risks and the financial implications they would like to hear more information from METRO staff prior to making any recommendations on this issue.

8. CONSIDERATION AND REVIEW OF CONSULTANT PAT PIRAS' PARACRUZ ELIGIBILITY STUDY

Pat Piras spoke about her recommendations regarding steps METRO could take in order to provide a higher level of service and to improve the eligibility process. Ms. Piras explained that the software used to help determine eligibility should be based on a functional model rather than a medical model and it should automatically interface with METRO's reservation system. Ciro Aguirre said there are a lot of pieces that still need to be put together and reviewed by METRO's Legal department to insure that it all complies with the law.

Vice Chair Mara Murphy stated that she feels there should be a 6-month evaluation period. April Warnock said that eligibility is approved for three years and that temporary eligibility is reviewed at the end of the temporary time period. Vice Chair Mara Murphy asked if a doctor determined temporary services? Pat Piras replied that the doctor doesn't get directly involved unless METRO has questions. If an individual indicates they expect to recover from an injury within 6 months they may get an 8-month eligibility. Temporary eligibility is tailored to what can be reasonably predicted with some margin of error.

9. REPORT BY MAC REPRESENTATIVE TO OTHER TRANSIT RELATED MEETINGS

Robert Yount reported on the stenciling of METRO logos on the bus stop benches, new bus stop developments in Boulder Creek at Mountain/ Highway 9 and Zayante Road/Felton Faire, and he updated the committee on the Felton Faire and the Soquel/Daubenbiss issues.

Vice Chair Mara Murphy mentioned she was interested in joining a newly organized ADA Committee and that she would have more information on it at a later date.

10. DISCUSS POSSIBILITY OF A WATSONVILLE MEETING AND ALTERNATE MEETING LOCATIONS

This item was continued to December to give METRO staff time to determine the feasibility.

11. HEADWAYS BUS SCHEDULE

Ciro Aguirre reported that enhancements to *Headways* include footnotes identifying UCSC trips that have back up service and the cover has been reconfigured.

Mary Ferrick said there would be some subtle changes on the integrated UCSC schedule including a new outbound stop to the 27X UC Express and later evening trips on the Route 20.

12. DISTRIBUTION OF MAC VOUCHERS

Ciro Aguirre distributed METRO MAC vouchers to the MAC members at this time.

13. COMMUNICATIONS TO METRO GENERAL MANAGER

None.

14. COMMUNICATIONS TO METRO BOARD OF DIRECTORS

None.

15. ITEMS FOR NEXT MEETING AGENDA

- Discuss Possibility of a Watsonville Meeting and Alternate Meeting Locations
- Consideration of Whether METRO Should Allow ParaCruz Eligible Riders Free Fares on METRO'S Fixed Route

ADJOURN

There being no further business, Chair Naomi Gunther thanked everyone for participating and adjourned the meeting at 7:58 p.m.

Respectfully submitted,



KAREN BLIGHT
Administrative Assistant

SANTA CRUZ METROPOLITAN TRANSIT DISTRICT

DATE: January 23, 2009
TO: Board of Directors
FROM: Angela Aitken, Finance Manager
SUBJECT: CONSIDERATION OF CONTRACT RENEWAL WITH SC FUELS FOR DELIVERY OF CARB ULTRA-LOW SULFUR DIESEL FUEL FOR AN AMOUNT NOT TO EXCEED \$1,500,000

I. RECOMMENDED ACTION

That the Board of Directors authorize the General Manager to enter into a one-year contract extension with SC Fuels for delivery of CARB ultra-low sulfur diesel fuel for an amount not to exceed \$1,500,000.

II. SUMMARY OF ISSUES

- METRO has a contract with SC Fuels for the delivery of CARB ultra-low sulfur diesel fuel.
- This contract was established on February 7, 2007 for a two-year period with three optional one-year extensions.
- The current contract approved by the Board of Directors will expire on January 31, 2009.
- SC Fuels has performed its duties very well under this contract and therefore, a one-year contract extension is recommended.
- Staff recommends that the Board of Directors authorize the General Manager to enter into a one-year contract extension with SC Fuels for delivery of CARB ultra-low sulfur diesel fuel for an amount not to exceed \$1,500,000.

III. DISCUSSION

METRO has a contract with SC Fuels for the delivery of CARB ultra-low sulfur diesel fuel that will expire on January 31, 2009. This contract was established on February 7, 2007 for a two-year period with three optional one-year extensions. During this contract period, the quality of service provided by SC Fuels has been excellent.

Staff recommends that the Board of Directors authorize the General Manager to enter into a one-year contract extension with SC Fuels for delivery of CARB ultra-low sulfur diesel fuel for an amount not to exceed \$1,500,000.

5-5.1

IV. FINANCIAL CONSIDERATIONS

Funds to support this contract are included in the Fleet FY09 Fuels and Lubricants – Revenue Vehicles budget.

V. ATTACHMENTS

None

Prepared By: Lloyd Longnecker, Purchasing Agent

5-5.2

SANTA CRUZ METROPOLITAN TRANSIT DISTRICT

DATE: January 23, 2009

TO: Board of Directors

FROM: Angela Aitken, Manager of Finance

SUBJECT: CONSIDERATION OF AWARD OF CONTRACT WITH FIRST CAPITOL AUCTION, INC. FOR PUBLIC AUCTION SERVICES

I. RECOMMENDED ACTION

That the Board of Directors authorize the General Manager to execute a one-year auction agreement with First Capitol Auction, Inc. for public auction services.

II. SUMMARY OF ISSUES

- Revenue and non-revenue vehicles, that are declared surplus to METRO's needs by the Board of Directors, are transported to an auctioneer for public auction sale.
- A request for auction services was solicited from qualified auction firms.
- Only one firm submitted a proposal for the METRO's review.
- Staff has reviewed and evaluated the proposal.
- Staff recommends that a one-year auction agreement be established with First Capitol Auction, Inc. to provide public auction services.

III. DISCUSSION

METRO requires public auction services for the sale of METRO transit buses, trucks, vans, automobiles and miscellaneous equipment that are surplus to the METRO's needs. A request for services was solicited from qualified auction firms. One proposal was received from First Capitol Auction, Inc. Staff have reviewed and evaluated the proposal.

First Capitol Auction, Inc., located in Vallejo, California, is a large public auction services provider. This firm provides public auction services six to eight times a year for transit agencies, cities, counties, utility companies, state, federal agencies and private industry.

First Capitol Auction, Inc. will pickup vehicles ready for auction, clean and smog the vehicle (if required) and process all DMV paperwork after the sale. First Capitol Auction, Inc. will perform an advertising campaign (mailers, emails to potential buyers, web site listings, etc.) prior to the auction date.

5-6.1

The agreement will require METRO to indemnify and defend auctioneer for METRO's negligent acts or it's willful misconduct.

Staff is recommending that the Board of Directors authorize the General Manager to sign a one-year auction agreement with First Capitol Auction, Inc. to provide public auction services. Contractor will provide services meeting all METRO specifications and requirements.

IV. FINANCIAL CONSIDERATIONS

First Capitol Auction, Inc. will deduct from the gross auction proceeds: Seven and one half percent (7.5%) for the sales of all vehicles and equipment; and twenty percent (20%) for miscellaneous items. Transportation charges of vehicles to auction site will be deducted as follows: \$95 per running vehicle and \$85 per hour for low bed trailer service. There will be no charge for auto washing, storage, State of California vehicle safety inspections, and smog services.

V. ATTACHMENTS

Attachment A: Auction Agreement with First Capitol Auction, Inc.

Prepared By: Lloyd Longnecker, Purchasing Agent

5-6.2

AUCTION AGREEMENT

For

SANTA CRUZ METROPOLITAN TRANSIT DISTRICT

370 ENCINAL STREET, SUITE 100

SANTA CRUZ, CA 95060

ATTN: LLOYD LONGNECKER

Submitted by:

FIRST CAPITOL AUCTION INC.

50 SOLANO AVENUE

VALLEJO, CA 94590

PHONE: (707) 552-0739

FAX: (707) 552-8613

EMAIL: [auction cap@aol.com](mailto:auctioncap@aol.com)

DATE: November 12, 2008

AUCTION AGREEMENT

FIRST CAPITOL AUCTION INC., now hereinafter referred to as (“Auctioneer”) and the undersigned (“Seller”) agree as follows:

1. AGENCY. Seller hereby appoints Auctioneer as its agent to conduct a Public Auction of personal property described below. Auctioneer shall be an independent contractor. Seller authorizes and confers upon Auctioneer the power to take all actions on its behalf necessary to complete the auction. Such as accepting cash or checks on behalf of Seller in payment for property sold, signing on behalf of Seller as the registered and/or legal owner of any motor vehicles sold to effect a transfer, and satisfying or compromising secured parties who hold or assert a lien on any Property sold at auction. Seller hereby agrees to sell the Property to the highest bidder, with no minimums, reservations, buy-backs or persons bidding for Seller. Absolutely under no circumstances whatsoever shall the Auctioneer or the staff assert a bid on behalf of an owner or consignor of equipment to this auction.
2. AUCTIONS AND PROPERTY. First Capitol Auction Inc conducts public auction about six to eight times a year at 50 Solano Avenue, City of Vallejo, State of California. None of the property may be sold before the auction without the written consent of both parties, in which case the sales proceeds shall be treated as part of the gross proceeds of the auction. All of the Property shall be at the auction at least one week prior to the auction and in the event of a failure of Seller to deliver said Property, or if Seller shall breach this contract, Seller agrees to pay the other costs as provided below and said commission based on market value of said property. First Capitol Auction, Inc. is a fully licensed auto dealer and is bonded with the State of California. Vehicles will not be offered at auction unless the Certificates of Ownership and all other documents necessary to affect a transfer of title for Motor Vehicles, Trailers and Towable Property are submitted to Auctioneer at least five (5) business days prior to the sale. All property submitted for auction shall be free and clear of any toxic waste and/or environmental hazards. If these are not environmentally safe, these items may incur additional fees or disposal costs.
3. First Capitol Auction Inc is in compliance with all State of California environmental requirements as well as in compliance with all current California Air Resource Board (CARB) requirements. For all CARB sales, you as the legal owner, must complete the “VIN Stop Request” form and submit it to CARB. The two (2) page “Out of State Sales Verification” forms should to be submitted to us upon delivery of the vehicle with “Selling Party’s Information, Vehicle Information and Engine Information” filled out. We in turn complete the “Purchaser Information” at the time of the sale notifying the buyer the item(s)

cannot be registered or operated in the State of California without being retrofitted to meet CARB requirements. The Auctioneer will submit the form back to the Seller for their records with payment.

4. COMMISSION AND EXPENSES.

A. Commission (Selling Fees)

1. Motor Vehicles and Off Road Vehicles	7.5%
2. Miscellaneous Property (Non-motor or Off Road Vehicles)	20%
3. Non running vehicles	7.5%
4. State of California Vehicle Safety Inspection	No Charge
5. Smog Service	No Charge

B. Transportation Charges an Other Services

1. Standard Towing: Non-Op Units.	See low bed
2. Standard Towing: Running Vehicles (6-8 Vehicles)	\$95.00/Veh
3. Low Bed Trailer Service	\$85.00/Hr
4. Surplus Personal Property (Miscellaneous)	\$85.00/Hr
5. Auto Wash	No Charge
6. Minor De-Identification of County and City Unites	\$50.00/Veh
7. Exempt Plates: Processing "E" Plates	No Charge
8. Storage Fees	No Charge

C. Additional Services Provided to the Public

1. Free Color Sales Brochure
2. Free Permanent Bidder Program (encouraging return bidders)
3. Free Auction Sale Catalog (this is an important selling aid for the buyer)
4. Three (3) way to bid at First Capitol Auction Inc.; live, absentee or online bidding
5. First Capitol Auction Inc does not allow or sell any special privileges such as pay to cut in line. We feel this practice is discriminatory.

6. Free hospitality barbeque at all heavy equipment sales to encourage bidder registration and inspection.

4. SECURITY INTEREST. Seller hereby gives Auctioneer a security interest in the Property and Equipment listed herein and now owned and hereinafter acquired by Seller (including insurance) and in the sales proceeds, in order to secure any and all advances which may be made to or on behalf of the Seller by Auctioneer and to secure any and all other obligations that the Seller may owe Auctioneer arising out of or in connection with this Agreement, the Property, and or any other agreement, transaction, or Property involving Seller and Auctioneer. Auctioneer shall have all the rights of a secured creditor under the Uniform Commercial code and Seller agrees to execute a financing statement enabling Auctioneer to perfect this security interest as a first lien on the Property listed herein.

5. REPRESENTATION AND INDEMNITY BY SELLER. Seller represents and warrants that title to the Property is and will be at the time of the auction, free and clear of any and all liens, security interests, encumbrances, rights and claims other than those of Auctioneer pursuant to this Agreement, Seller further represents and warrants that Seller has used no other business name or address other than the names and addresses specified in this Agreement.

Auctioneer hereby indemnifies, defends and holds Seller harmless from and against any and all losses, costs, expenses, demands, claim, causes of action and liabilities (including without limitation, reasonable attorney's fees) (collectively "losses and liabilities") related directly or indirectly to, arising out of, or in connection with the performance of services by Auctioneer under this Agreement, caused in whole or in part by the willful misconduct or any negligent act or omission of the Auctioneer, any subcontractor, anyone directly or indirectly employed by any of tem or anyone for whose acts any of them may be liable, except where caused by the active negligence, sole negligence, or willful misconduct of Seller.

Seller hereby indemnifies, defends and holds Auctioneer harmless from and against any and all losses, costs, expenses, demands, claims, causes of action, and liabilities (including without limitation, reasonable attorney's fees) (collectively "losses and liabilities") arising out of the Seller's execution of its obligations under this Agreement, caused by Seller's active negligence, sole negligence, or willful misconduct.

First Capitol Auction, Inc. and its consignors will indemnify and hold harmless Selling agency, its boards, commissions, officers and employees in performance of services here under. First Capitol Auction, Inc. will provide comprehensive general liability insurance not less then \$1,000,000.

6. GENERAL PROVISIONS

1. Within fifteen (15) banking days after the auction date, Auctioneer shall present a full accounting of the sales proceeds and expenses, and shall, if requested, document the accounting by invoices and/or vouchers. With such accounting, Auctioneer shall present Seller with a check for all monies due from such action unless delayed by legal proceedings or inability of Auctioneer, through no fault of its own, to transfer title or to comply with the Uniform

Commercial code or other laws. Auctioneer reserves the right to eliminate from settlement any property for which payment has not been made and Seller agrees to accept responsibility for reclaiming same wherever located. Auction may at their own discretion charge a 10% buyer's premium.

2. In the event a dispute arises out of this agreement, the prevailing party shall be entitled to reasonable attorney's fees from the other party.

3. The duration of this contract shall be for a minimum of three (3) years with the option of a one (1) year extension.

First Capitol Auction Inc
50 Solano Avenue
Vallejo, Ca 94590

Santa Cruz Metropolitan Transit District
370 Encinal Street, Suite 100
Santa Cruz, Ca 95060

By: _____

By: _____

Print: _____

Print: _____

Title: _____

Title: _____

Date: _____

Date: _____

SANTA CRUZ METROPOLITAN TRANSIT DISTRICT

DATE: January 23, 2009

TO: Board of Directors

FROM: Les White, General Manager

**SUBJECT: CONSIDERATION OF DESIGNATION OF ASSISTANT FINANCE
MANAGER TO CALTIP BOARD OF DIRECTORS AND
MANAGER OF OPERATIONS AS DESIGNATED ALTERNATE**

I. RECOMMENDED ACTION

Staff recommends that the Board of Directors adopt the attached resolution designating the Assistant Finance Manager to the CalTIP Board of Directors and the Manager of Operations as the Designated Alternate.

II. SUMMARY OF ISSUES

- The District's casualty and liability insurance is provided through CalTIP, a self insured pool of California transit operators.
- The District is required to designate a representative to the CalTIP Board of Directors and an alternate representative.
- Since the CalTIP Board of Directors sets policy that affects many aspects of the District's risk management, operations and maintenance functions, the Board appointed the Assistant General Manager as the District's primary representative in 1998.
- With the retirement of the Assistant General Manager, it is necessary to appoint a replacement.
- Staff is also recommending that the Manager of Operations as the person responsible for the system safety plans be appointed as the Designated Alternate.

III. DISCUSSION

The District is a charter member of CalTIP, which was established in 1987. The Assistant General Manager has been METRO's CalTIP Director since 1998. With the retirement of the Assistant General Manager, it is necessary to appoint a new Director. Staff is recommending that the Assistant Finance Manager be appointed as METRO's Director on CalTIP. In addition, the Manager of Operations is directly involved with METRO's

5-7.1

Safety Plans, including operational responsibility for the Bus Operators, so it is recommended that he be appointed as the Designated Alternate.

IV. FINANCIAL CONSIDERATIONS

There are no financial impacts, as CalTIP reimburses for all related travel expenses.

V. ATTACHMENTS

Attachment A: Resolution appointing Director and Alternate Member of the California Transit Insurance Pool (CalTIP)

**BEFORE THE BOARD OF DIRECTORS OF THE
SANTA CRUZ METROPOLITAN TRANSIT DISTRICT**

Attachment A

Resolution No. _____

On the Motion of Director: _____

Duly Seconded by Director: _____

The Following Resolution is Adopted:

**RESOLUTION APPOINTING DIRECTOR
AND ALTERNATE MEMBER OF THE
CALIFORNIA TRANSIT INSURANCE POOL (CAL TIP)**

WHEREAS, the Board of Directors of the Santa Cruz Metropolitan Transit District, at its April 17, 1987 meeting, did hereby authorize participation by the District in the California Transit Insurance Pool (CalTIP) beginning July 1, 1987; and

WHEREAS, it is necessary for the Board of Directors to approve appointments of a Director and an alternate Director of the California Transit Insurance Pool; and

NOW, THEREFORE, BE IT RESOLVED AND ORDERED, that the Assistant Finance Manager is hereby appointed the Director and Manager of Operations is hereby appointed the alternate Director of the California Transit Insurance Pool to serve at the pleasure of the Board of Directors of the Santa Cruz Metropolitan Transit District

PASSED AND ADOPTED this 23rd day of January 2009, by the following vote:

AYES: Directors –

NOES: Directors –

ABSTAIN: Directors –

ABSENT: Directors –

APPROVED _____

Board Chair

ATTEST _____

LESLIE R. WHITE
Secretary/General Manager

APPROVED AS TO FORM:

MARGARET GALLAGHER
District Counsel

5-7.a1

SANTA CRUZ METROPOLITAN TRANSIT DISTRICT

STAFF REPORT

DATE: January 23, 2009

TO: Board of Directors

FROM: Margaret Gallagher, District Counsel

SUBJECT: **CONSIDERATION OF AUTHORIZING THE GENERAL MANAGER TO EXECUTE A CONTRACT WITH SUE CLARKE FOR CONTINUING TO AUDIT THE TALKING BUSES EXTERNAL ANNOUNCEMENTS AT THE BART CAVALLARO TRANSIT CENTER**

I. RECOMMENDED ACTION

Authorize the General Manager to Execute a Contract with Sue Clarke for Auditing of the external route announcements at the Cavallaro Transit Center.

II. SUMMARY OF ISSUES

- Santa Cruz METRO is required by the Americans with Disabilities Act to make Call Stop Announcements. The announcements can be made either through the use of Talking Bus Equipment or by the individual bus operators. METRO purchased Talking Bus Equipment for purposes of making the required announcements.
- Sue Clarke has been auditing the Talking Bus external announcements at the Watsonville Transit Center and Bart Cavallaro Transit Center since July 1, 2007. The information contained in Ms. Clarke's audit reports was provided in the quarterly Call Stop Reports provided to the Board of Directors through the second quarter of 2008.
- Beginning in August of 2008, the security guards at the Watsonville Transit Center began performing the external bus audits. Sue Clarke has continued to perform the external bus audits at the Bart Cavallaro Transit Center. Clarke's contract expires on 12/31/08.

III. DISCUSSION

Santa Cruz METRO is required by the Americans with Disabilities Act to make Call Stop Announcements. METRO purchased the talking bus equipment for purposes of making the required announcements. The equipment provides for internal and external announcements. The external announcements that announce the bus route for each bus are made at the Transit Centers and at the bus stops. These announcements alert potential passengers that a particular bus will be following a specific route. These announcements are critical to insure that all passengers know which bus they should board to get to their destination. METRO staff has determined that at the Transit Centers the external announcements should call out the routes four times before the bus departs from the center.

The purpose of the contract with Sue Clarke is so that she can verify that the bus operators are making the required four announcements before they depart from the Bart Cavallaro Transit Center. This verification system will ensure that METRO is able to properly defend itself should anyone dispute that METRO is calling out the stops in compliance with the law.

Attached is the current contract for Sue Clarke, who has been auditing the required external announcements at the Watsonville Transit Center and Bart Cavallaro Transit Center since July 1, 2007. Her contract was modified in August of 2008 to only include the Bart Cavallaro Transit Center. The security guards at the Watsonville Transit Center began performing the audit at that location. Ms. Clarke's current contract expires on 12/31/08. If the Board of Directors approves this recommendation to continue the audits, this current contract will be used for the new contract, the only change will be in the contract period, which will be February 1, 2009 through December 31, 2009. Ms. Clarke will continue performing audits at the Bart Cavallaro Transit Center only, not to exceed five hours per week.

IV. FINANCIAL CONSIDERATIONS

Ms. Clarke has been auditing 5 hours per week. She is paid at the rate of \$25.00 per hour, or \$125.00 per week. This contract would continue these financial arrangements through the end of 2009.

V. ATTACHMENTS

Attachment A: Current Independent Contractor Agreement

5-8.2

Contract No. _____

INDEPENDENT CONTRACTOR AGREEMENT

THIS CONTRACT is entered into this 1st day of February, 2009, by and between the SANTA CRUZ METROPOLITAN TRANSIT DISTRICT, hereinafter called METRO, and Susan Clarke, hereinafter called CONTRACTOR. The parties agree as follows:

1. METRO NEEDS:

METRO has a need for a Call Stop Surveyor who will audit the METRO buses at the Bart Cavallaro Transit Center to determine how many times those buses audited make the external route announcements before departing from the transit center. Contractor has a desire to audit buses at this transit center for METRO under the terms and conditions set forth herein.

2. DUTIES:

CONTRACTOR agrees to exercise special skill to accomplish the following result: **Audit External Bus Announcements at the Bart Cavallaro Transit Center and provide information to METRO re each audit and its results.**

3. COMPENSATION:

In consideration for CONTRACTOR accomplishing said result, METRO agrees to pay CONTRACTOR as follows: **\$25.00 per hour to a maximum of 5 hours per week. Contractor shall bill the District monthly setting forth the time, date, location, bus number and audit results of each bus audited and the specific times and dates that Contractor was in audit status.**

4. TERM:

The term of this contract shall be effective from February 1, 2009 through December 31, 2009.

5. EARLY TERMINATION:

Either party hereto may terminate this contract at any time by giving (30) days written notice to the other party.

6. INDEMNIFICATION FOR DAMAGES, TAXES AND CONTRIBUTIONS:

CONTRACTOR shall exonerate, indemnify, defend, and hold harmless METRO (which for the purpose of paragraphs 5 and 6 shall include, without limitation, its officers, agents, employees and volunteers) from and against:

- A. Any and all claims, demands, losses, damages, defense costs, or liability of any kind or nature which METRO may sustain or incur or which may be imposed upon it for injury to or death of persons, or damage to property as a result of, arising out of, or in any manner connected with the CONTRACTOR'S performance under the terms of this Agreement, excepting any liability arising out of the sole negligence of the

METRO. Such indemnification includes any damage to person(s), or property (ies) of CONTRACTOR and third persons.

- B. Any and all Federal, State and Local taxes, charges, fees, or contributions required to be paid with respect to METRO and METRO's officers, employees and agents engaged in the performance of this Agreement (including, without limitation, unemployment insurance, social security and payroll tax withholding).

7. EQUAL EMPLOYMENT OPPORTUNITY.

During and in relation to the performance of this Agreement, CONTRACTOR agrees as follows:

The CONTRACTOR shall not discriminate against any METRO employee because of race, color, religion, national origin, ancestry, physical or mental disability, medical condition (cancer related), marital status, sex, sexual orientation, age (over 40), veteran status, or any other non-merit factor unrelated to job duties.

8. INDEPENDENT CONTRACTOR STATUS.

CONTRACTOR and METRO have reviewed and considered the principal test and secondary factors below and agree that CONTRACTOR is an independent contractor and not an employee of the METRO. CONTRACTOR is responsible for all insurance (workers compensation, unemployment, etc.) and all payroll related taxes. METRO agrees that CONTRACTOR shall have the right to control the manner and means of accomplishing the result contracted for herein.

PRINCIPAL TEST: The CONTRACTOR rather than the METRO has the right to control the manner and means of accomplishing the result contracted for.

SECONDARY FACTORS:

- (a) The extent of control which, by agreement, METRO may exercise over the details of the work is slight rather than substantial; (b) CONTRACTOR is engaged in a distinct occupation or business; (c) In the locality, the work to be done by CONTRACTOR is usually done by a specialist without supervision, rather than under the direction of an employer; (d) The skill required in the particular occupation is substantial rather than slight; (e) The CONTRACTOR rather than the METRO supplies the instrumentality, tools and work place; (f) The length of time for which CONTRACTOR is engaged is of limited duration rather than indefinite; (g) The method of payment of CONTRACTOR is by the job rather than by the time; (h) The work is part of a special or permissive activity, program or project, rather than part of the regular business of METRO; (i) CONTRACTOR and METRO believe they are creating an independent contractor relationship rather than an employer-employee relationship; and (j) The METRO conducts public transportation business.

It is recognized that it is not necessary that all secondary factors support creation of an independent contractor relationship, but rather that overall there are significant secondary factors that indicate that CONTRACTOR is an independent contractor.

5-8.92

By their signatures to this Agreement, each of the undersigned certifies that it is his considered judgment that the CONTRACTOR engaged under this Agreement is in fact an independent contractor.

9. NONASSIGNMENT.

CONTRACTOR shall not assign this Agreement without prior written consent of the METRO.

10. RETENTION AND AUDIT OF RECORDS.

CONTRACTOR shall retain records pertinent to this Agreement for a period of not less than five (5) years after final payment under this Agreement or until a final audit report is accepted by METRO, whichever comes first. CONTRACTOR hereby agrees to be subject to the examination and audit by the METRO, the Auditor General of the State of California, or the designee of either for a period of five (5) years after final payment under this Agreement.

11. ATTACHMENTS

This Agreement includes the following attachments (identify by name or write "NONE"):

NONE

12. NOTICES:

Any notice, demand, request, consent approval or communication that either party desires or is required to give to the other party shall be in writing and either served personally by depositing the same in the United States Postal Service, registered or certified mail, return receipt requested with the postage prepaid, addressed to the other party at the address set forth below. Either party may change its address by notifying the other party of the change of address by compliance with this section. Notice shall be deemed communicated within forty-eight hours from the time of mailing if mailed as provided in this Article 12.

METRO:
Margaret Gallagher
District Counsel
Santa Cruz Metropolitan Transit District
370 Encinal Street, Suite 100
Santa Cruz, CA 95060

CONTRACTOR:
Susan Clarke
325 Vista Robles Drive
Ben Lomond, CA 95005

13. TIME OF THE ESSENCE:

Time is of the essence of each provision of this Agreement.

5-8.a3

14. DRUG AND ALCOHOL POLICY

Contractor and its employees shall not use, possess, manufacture, or distribute alcohol or illegal drugs while on the premises at any District facility, or distribute same to METRO's employees, passengers, or the general public.

15. SMOKE FREE

The Centers are smoke free facilities. Contractor shall comply with State law and the City Ordinance regarding smoking. Contractor and its employees and customers shall not smoke tobacco products at the Transit Centers or while performing services under this Agreement.

16. ALL AMENDMENTS IN WRITING

No amendment to this Agreement shall be effective unless it is in writing and signed by duly authorized representatives of both parties.

17. NONDISCRIMINATION

Contractor shall not discriminate on the grounds of race, religion, color, sex, age, marital status, medical condition, disability, national origin or sexual preference in any manner or as a result of or arising out of this Agreement agreement.

18. NO CONFLICT OF INTEREST

Contractor represents that it currently has no interest, and shall not have any interest, direct or indirect, that would conflict in any manner with the performance of services required under this Contract.

19. GOVERNING LAW & COMPLIANCE WITH ALL LAWS

This Contract is governed by and construed in accordance with the laws of California. Each party will perform its obligations hereunder in accordance with all applicable laws, rules, and regulations now or hereafter in effect. Contractor shall ensure throughout the terms of this Agreement that all federal, state and local laws and requirements are met including any requirements District is obligated to perform because of receipt of grant funding. Contractor shall also be required to fulfill its obligation as a federal and/or state and/or local sub-recipient of grant funding.

20. ATTORNEYS' FEES

In the event suit is brought to enforce or interpret any part of this Agreement, the prevailing party shall be entitled to recover as an element of costs of suit, and not as damages, a reasonable attorney's fee to be fixed by the court. The "prevailing party" shall be the party who is entitled to recover his costs of suit, whether or not the suit proceeds to final judgment. A party not entitled to recover his costs shall not recover attorney's fees. No sum for attorney's fees shall be counted in calculating the amount of

5-8.94

a judgment for purposes of determining whether a party is entitled to recover his costs of attorney's fees.

21. AUTHORITY

Each party has full power and authority to enter into and perform this Agreement, and the person(s) signing this Agreement on behalf of each has been properly authorized and empowered to enter into this Agreement. Each party further acknowledges that it has read this Agreement, understands it, and agrees to be bound by it.

IN WITNESS WHEREOF, the parties hereto have set their hands the day and year first above written.

METRO

CONTRACTOR

By: _____

By: _____

370 Encinal Street, Ste. 100
Santa Cruz, CA 95060
(831) 426-6080

Address:

APPROVED AS TO FORM:

Telephone:

By: _____
District Counsel

Federal Tax ID No:

DISTRIBUTION:
Contractor
Administration
Finance
Purchasing
Department Manager

5-8.a5

SANTA CRUZ METROPOLITAN TRANSIT DISTRICT

DATE: January 23, 2009

TO: Board of Directors

FROM: Angela Aitken, Finance Manager

SUBJECT: PUBLIC HEARING: CONSIDERATION OF ADOPTING A PROGRAM OF PROJECTS FOR FY09 FEDERAL FUNDING ASSISTANCE AND ADOPTING A RESOLUTION AUTHORIZING THE APPLICATION AND EXECUTION OF GRANTS FOR FY09 FEDERAL FUNDS.

I. RECOMMENDED ACTION

That the Board of Directors receive public comments and adopt a Program of Projects for FY09 federal funding assistance and adopt a Resolution authorizing applications to Caltrans and FTA for FY09 federal funds.

II. SUMMARY OF ISSUES

- The *Safe, Accountable, Flexible, Efficient Transportation Equity Act: A Legacy for Users* (SAFETEA-LU) provides federal financial assistance to METRO through the Federal Transit Administration (FTA) for public transit operations and capital developments. A public hearing is required to give the public an opportunity to comment on METRO's federally funded operating and capital projects.
- The Federal Transit Administration (FTA) provides Urbanized Area Formula assistance directly to METRO. The current appropriation provides funds through March 6, 2009.
- Caltrans administers the FTA Rural operating assistance program in California. METRO must submit an application and execute an agreement with Caltrans to receive \$170,894 in rural operating assistance for FY09.
- Conducting a public hearing on the Program of Projects (Attachment A) enables the Board to consider comments from interested parties on the proposed projects for federal funding assistance
- Adopting the attached resolution (Attachment B) authorizes METRO staff to submit an application to Caltrans and execute agreements for Rural Operating assistance.

III. DISCUSSION

The *Safe, Accountable, Flexible and Efficient Transportation Equity Act: A Legacy for Users* (SAFETEA-LU) legislated programs within the Federal Transit Administration

(FTA) to provide financial assistance to public transit operators. As in previous years, METRO receives federal operating assistance through the Urbanized Area Formula Program (49 USC §5307) which includes the Small Transit Intensive Cities (STIC) performance based tier of assistance. METRO has budgeted the STIC amount for MetroBase construction.

The current FTA apportionment provides funding only for the partial fiscal year from October 1, 2008 through March 6, 2009. Because Congress did not yet pass legislation to fund the Department of Transportation in FY09, it enacted and the President signed the Continuing Appropriations Act, 2009 to fund transportation programs at the same level as in FY08 until a new budget is passed, or until March 6, 2009 at the latest. The amount of FTA funds in the current apportionment for the §5307 Urbanized Area Formula program represents approximately 43% of the amount anticipated for FY09 if it continues to be funded at the same level.

From the appropriation of \$1,883,357 in §5307 funds, METRO proposes to allocate \$1,542,399 to FY09 Urbanized Area operating assistance and \$340,958 to MetroBase construction. When FTA provides the Final FY09 apportionments, METRO will amend the Program of Projects to add the remaining funding assistance for FY09.

Caltrans administers the FTA rural operating assistance program (49 USC §5311) in California, and METRO will make a separate application to Caltrans for \$170,894 in rural operating assistance available for FY09. Since Caltrans distributes operating assistance to small operators based on statewide, pooled resources rather than strictly by formula, it is making all of METRO's FY09 rural operating assistance available at this time. METRO will spend approximately \$1,654,493 to operate public transit service on seven routes serving the rural areas of Santa Cruz County.

The public hearing provides an opportunity to consider comments from interested parties on the proposed Program of Projects for federal operating assistance. If no changes are made to the attached Program of Projects, it will become the final Program of Projects for FY09 and staff will submit applications based upon this list of projects. Staff published a notice of the public hearing in the *Santa Cruz Sentinel* and the *Watsonville Pajaronian*.

Adopting the attached resolution (Attachment B) authorizes the General Manager to submit an application and execute an agreement with Caltrans for the rural operating assistance. METRO has a standing agreement previously approved by the Board of Directors to submit grants and execute agreements with the FTA.

IV. FINANCIAL CONSIDERATIONS

The FTA §5307 Program contributes \$1,542,399 for FY09 urban operating assistance and \$340,958 in construction funds for MetroBase. The FTA §5311 Program contributes \$170,894 in rural operating assistance for FY09. Local sales tax revenue and capital reserves provide the required local match for these projects.

V. ATTACHMENTS

Attachment A: Program of Projects for FTA §5307 and §5311 Funds

Attachment B: Resolution authorizing an application for FY09 FTA §5311 Rural Operating Assistance

**Santa Cruz Metropolitan Transit District
FY 2009 Program of Projects
Using Federal Transit Administration Funds**

The Federal Transit Administration (FTA) has appropriated \$1,883,357 in federal funds to the Santa Cruz Metropolitan Transit District (METRO) for public transit operations and capital improvements during FY 2009. In addition, the California Department of Transportation (**Caltrans**) allocated to METRO \$170,894 from its appropriation of FTA funds. METRO, in accordance with 49 USC Parts 5307 and 5311, proposes the following Program of Projects for these FTA funds:

- I. FY 2009 Urbanized Area Formula Funds, 49 USC §5307:
 - A. \$1,542,399 for urbanized area public transit for the period July 1, 2008 through March 6, 2009. This project provides public transit conforming to land use and transportation plans in Santa Cruz County without causing negative environmental impacts or relocation of families or businesses. Local sales tax, Transportation Development Act and passenger fare revenue pay the balance of FY09 annual operating costs totaling \$38,620,890.
 - B. \$340,958 for the MetroBase Consolidated Operating Facility in Harvey West Industrial Park for the period July 1, 2008 through March 6, 2009. This project is currently under construction.
- II. FY 2009 Rural Operating Assistance, 49 USC §5311:

The California Department of Transportation allocated \$170,894 in FTA funds (49 USC §5311) to METRO for rural public transit operating assistance for the period July 1, 2008 through June 30, 2009. Total cost for this service will be approximately \$1,654,493 with \$282,830 paid from farebox revenue and \$1,200,769 paid from local sales tax revenue.

If adopted by the Board, this list will become the final program of projects and METRO staff will submit applications to the FTA and Caltrans requesting federal funding assistance.

BEFORE THE BOARD OF DIRECTORS OF THE
SANTA CRUZ METROPOLITAN TRANSIT DISTRICT

Attachment **B**

Resolution No. _____

On the Motion of Director: _____

Duly Seconded by Director: _____

The Following Resolution is Adopted:

**A RESOLUTION
AUTHORIZING AN APPLICATION
TO THE CALIFORNIA DEPARTMENT OF TRANSPORTATION
FOR
FTA SECTION 5311 FY09 RURAL OPERATING ASSISTANCE**

WHEREAS, the Federal Transit Act authorizes financial assistance to public transit operators in non-urbanized areas as directed by 49 CFR 5311; and

WHEREAS, the California Department of Transportation administers the Section 5311 program in California and allocates federal funds by formula to each county with intercity public transit between urban areas including more than 50,000 persons; and

WHEREAS, the Santa Cruz Metropolitan Transit District operates intercity public transit in Santa Cruz County and is the only public transit operator designated to receive federal financial assistance from the Section 5311 program; and

WHEREAS, all applications for financial assistance impose certain obligations upon the applicant, including the provision of local share costs of the project.

NOW, THEREFORE, BE IT RESOLVED AND ORDERED BY THE SANTA CRUZ METROPOLITAN TRANSIT DISTRICT:

1. That the General Manager is authorized to submit an application to the State of California Department of Transportation on behalf of the Santa Cruz Metropolitan Transit District for financial assistance to operate public transit service in the non-urbanized portion of Santa Cruz County.
2. That the General Manager is authorized to submit and file with this application all assurances and all supplemental information as required by the California Department of Transportation.
3. That the General Manager is designated to execute standard grant agreements with the California Department of Transportation on behalf of the Santa Cruz Metropolitan Transit District to obtain \$170,894 in FTA Section 5311 funds for Fiscal Year 2009 to assist with public transit operations in the non-urbanized portion of Santa Cruz County.
4. That the District has committed \$1,200,769 in local matching funds to the project.

7.61

5. That the Santa Cruz Metropolitan Transit District has, to the extent feasible, coordinated this project with other transportation providers and users in the region, including social service agencies capable of purchasing public transit.

PASSED AND ADOPTED this 23rd day of January, 2009 by the following vote:

AYES: Directors -

NOES: Directors -

ABSTAIN: Directors -

ABSENT: Directors -

APPROVED _____

Board Chair

ATTEST _____

LESLIE R. WHITE
General Manager

APPROVED AS TO FORM:

MARGARET GALLAGHER
District Counsel

7.62

SANTA CRUZ METROPOLITAN TRANSIT DISTRICT

DATE: January 9, 2009

TO: Board of Directors

FROM: Angela Aitken, Finance Manager
Frank L. Cheng, Project Manager

SUBJECT: CONSIDERATION OF AWARD OF CONTRACT FOR DEMOLITION AND REPAVING OF THE OLD BUS WASH AREA AT 1200 RIVER STREET, SANTA CRUZ WITH JOS. J. ALBANESE, INC.

ACTION REQUESTED AT THE JANUARY 9, 2009 BOARD MEETING

I. RECOMMENDED ACTION

That the Board of Directors authorize the General Manager to execute a contract for demolition and repaving of the old bus wash area at 1200 River Street, Santa Cruz with Jos. J. Albanese, Inc. for a total amount not to exceed \$28,850.

II. SUMMARY OF ISSUES

- METRO requires additional parking space for buses at the Operations Facility.
- A competitive procurement was conducted to solicit bids from qualified firms for the demolition and repaving of the old bus wash area.
- Eleven firms submitted bids for the METRO's review.
- Staff has reviewed all submitted bids.
- Staff recommends that the Board of Directors authorize the General Manager to sign a contract with Jos. J. Albanese, Inc. for demolition and repaving of the old bus wash area at 1200 River Street, Santa Cruz for an amount not to exceed \$28,850.

III. DISCUSSION

In order to provide much needed parking space at the Operations Facility, METRO requested bids from demolition/construction firms for the demolition and repaving of the old bus wash area at the Operations Yard. On October 24, 2008, METRO Invitation for Bid No. 09-01 was mailed to over thirty construction firms and five builders exchanges, was legally advertised, and a notice was posted on the METRO's web site. On December 19, 2008 bids were received and opened from eleven firms. A list of firms and a summary of the bids received are provided in Attachment A. Staff has reviewed all submitted bids.

Staff recommends that the Board of Directors authorize the General Manager to sign a contract with Jos. J. Albanese, Inc. for demolition of the old bus wash area at 1200 River Street, Santa

Cruz for an amount not to exceed \$28,850. Contractor will provide all demolition and repaving services meeting all METRO specifications and requirements.

IV. FINANCIAL CONSIDERATIONS

Funds to support contract are included in the MetroBase Operations Facility Capital Budget

V. ATTACHMENTS

Attachment A: Summary of Bids Received

Attachment B: Contract with Jos. J. Albanese, Inc.

Prepared By: Lloyd Longnecker, Purchasing Agent

Note: The IFB along with its Exhibits and any Addendum(s) are available for review at the Administration Office of METRO or online at www.scmttd.com

**IFB No. 09-01 for Demolition of the Old Bus Wash Area
Located at 1200 River Street, Santa Cruz**

Summary of Bids Received

1. Jos. J. Albanese, Inc. of Santa Clara, California	\$28,850
2. Weber Tractor Service of Redwood City, California	\$38,779
3. Mark Nicholson, Inc. of Hollister, California	\$41,810.37
4. T. Boyd Construction of Couer D Alene, Idaho	\$47,000
5. Community Tree Service & Demolition of Watsonville, CA	\$47,486.92
6. PARC Services, Inc. of Livermore, California	\$62,000
7. Machado Brothers, Inc. of Petaluma, California	\$63,793
8. Randazzo Enterprises, Inc. of Castroville, California	\$65,098
9. PSC – Industrial Services Div. - Demolition of San Ardo, CA	\$74,965
10. HSR General Engineering Contractors, Inc. of Santa Clara, CA	\$78,136
11. Universal Structures of Salinas, California	\$84,000

CONTRACT FOR DEMOLITION SERVICES (09-01)

THIS CONTRACT is made effective on January 9, 2009 between the SANTA CRUZ METROPOLITAN TRANSIT DISTRICT, a political subdivision of the State of California ("METRO"), and **Jos. J. Albanese, Inc.** ("Contractor").

1. RECITALS

1.01 METRO's Primary Objective

METRO is a public entity whose primary objective is providing public transportation and has its principal office at 370 Encinal Street, Suite 100, Santa Cruz, California 95060.

1.02 METRO's Need For Demolition Of Old Bus Wash Area

METRO requires demolition of Old Bus Wash Area. In order to obtain said demolition of Old Bus Wash Area, METRO issued an Invitation for Bids, dated October 24, 2008 setting forth specifications for demolition of Old Bus Wash Area. The Invitation for Bids is attached hereto and incorporated herein by reference as Exhibit A.

1.03 Contractor's Bid Form

Contractor is a supplier of demolition services desired by METRO and whose principal place of business is 986 Walsh Ave., Santa Clara, CA. Pursuant to the Invitation for Bids by the METRO, Contractor submitted a bid for Provision of said demolition of Old Bus Wash Area, which is attached hereto and incorporated herein by reference as Exhibit B.

1.04 Selection of Contractor and Intent of Contract

On January 9, 2009, METRO selected Contractor as the lowest responsive, responsible bidder to provide said demolition services. The purpose of this Contract is to set forth the provisions of this procurement.

1.05 Contractor and Supplier Synonymous

For the purposes of this Contract, the terms "contractor" and "supplier" are synonymous.

METRO and Contractor agree as follows:

2. INCORPORATED DOCUMENTS AND APPLICABLE LAW

2.01 Documents Incorporated in This Contract

The documents below are attached to this Contract and by reference made a part hereof. This is an integrated Contract. This writing constitutes the final expression of the parties' Contract, and it is a complete and exclusive statement of the provisions of that Contract, except for written amendments, if any, made after the date of this Contract in accordance with Section 13.14 of the General Conditions of the Contract.

a) Exhibit A

Santa Cruz Metropolitan Transit District's "Invitation for Bids" dated October 24, 2008 including addendum number 1 dated November 8, 2008, addendum number 2 dated December 3, 2008, and addendum number 3 dated December 10, 2008.

b) Exhibit B (Bid Form)

Contractor's Bid Form to METRO for demolition of Old Bus Wash Area, signed by Contractor and dated December 18, 2008.

2.02 Conflicts

Where in conflict, the provisions of this writing supersede those of the above-referenced documents, Exhibits A and B. Where in conflict, the provisions of Exhibit A supersede Exhibit B.

2.03 Recitals

The Recitals set forth in Article 1 are part of this Contract.

3. TIME OF PERFORMANCE

3.01 General

Contractor shall perform work under this Contract at such times to enable it to meet the time schedules specified in the Specifications Section of the IFB. The Contractor shall not be responsible for delays caused by force majeure events described in Section 2 of the General Conditions of the Contract.

3.02 Term

The term of this Contract commences on the date of execution and shall remain in force for a one (1) year period thereafter. METRO and Contractor may extend the term of this Contract at any time for any reason upon mutual written consent.

4. COMPENSATION

4.01 Terms of Payment

Upon written acceptance, METRO agrees to pay Contractor as identified in the Bid Form, Exhibit B, an amount not to exceed \$28,850, for satisfactory completion of all work under the terms and provisions of this Contract within forty-five (45) days thereof. Contractor understands and agrees that if he/she exceeds the \$28,850 maximum amount payable under this contract, that it does so at its own risk.

4.02 Invoices

Contractor shall submit invoices with a purchase order number provided by METRO. Contractor's invoices shall include detailed records showing actual time devoted, work accomplished, date work accomplished, personnel used, and amount billed per hour. Expenses shall only be billed if allowed under the contract. Telephone call expenses shall show the nature of the call and identify location and individual called.

Said invoice records shall be kept up-to-date at all times and shall be available for inspection by METRO (or any grantor of the METRO, including, without limitation, any State or Federal agency providing project funding or reimbursement) at any time for any reason upon demand for not less than four (4) years after the date of expiration or termination of the contract. Under penalty of law, Contractor represents that all amounts billed to METRO are (1) actually incurred; (2) reasonable in amount; (3) related to this contract; and (4) necessary for performance of the services. No expenses shall be paid by METRO unless specifically allowed by this contract.

5. NOTICES

All notices under this Contract shall be deemed duly given upon delivery, if delivered by hand; or three (3) days after posting, if sent by registered mail, receipt requested; to a party hereto at the address hereinunder set forth or to such other address as a party may designate by notice pursuant hereto.

METRO

Santa Cruz Metropolitan Transit District
370 Encinal Street, Suite 100
Santa Cruz, CA 95060
Attn: General Manager

CONTRACTOR

Jos. J. Albanese, Inc.
985 Walsh Avenue
Santa Clara, CA 95050
Attn: Chris Albanese, Project Manager

6. AUTHORITY

Each party has full power and authority to enter into and perform this Contract and the person signing this Contract on behalf of each has been properly authorized and empowered to enter into it. Each party further acknowledges that it has read this Contract, understands it, and agrees to be bound by it.

Signed on _____

METRO--SANTA CRUZ METROPOLITAN TRANSIT DISTRICT

Leslie R. White
General Manager

CONTRACTOR—JOS. J. ALBANESE, INC.

By _____
John L. Albanese
President

Approved as to Form:

Margaret Rose Gallagher
District Counsel

EXHIBIT -A-

SANTA CRUZ METROPOLITAN TRANSIT DISTRICT

Invitation for Bids (IFB)

**For Demolition of Old Bus Wash Area at
1200 River Street, Santa Cruz**

District IFB No. 09-01

Date Issued: October 24, 2008

Bid Deadline: 2:00 p.m., December 5, 2008



Contents of this IFB

Part I.	Bid Form
Part II.	Instructions to Bidders
Part III.	Specifications
Part IV.	General Conditions of the Contract
Part V.	Special Conditions of the Contract
Part VI.	Contract
Part VII.	FTA Requirements for Construction Contracts
Part VIII.	Protest Procedures

Attachment A – Project Drawings

PART I

BID FORM

The undersigned ("Bidder"), upon acceptance by the District, agrees to furnish all labor, freight, transportation, materials, equipment, services, supplies and other work in accordance with the Invitation for Bids entitled Item dated October 24, 2008 at the following prices

Item No.	Item Description	Quantity	Total Contract Price Including All Labor, Parts, Materials, Equipment, Incidentals And Any Applicable Taxes
1	Demolition of old bus wash area located at 1200 River Street, Santa Cruz as per all specifications, instructions, and conditions of District IFB No. 09-01.	1 Lot	

The successful bidder obligates him/herself to provide any or all of the bid items at the bid price. District reserves the right to award bid items separately or as a package. District may accept or reject the bid items at its discretion. Award of the bid will be based on totals provided for the Base Items. Options shall not be used in the determination of low bid. The Board of Directors also reserves the right to reject all bids for any reason.

Bidder has examined and is fully familiar with all terms and conditions of the Invitation for Bids and any addenda issued by the District thereto, and Bidder unconditionally submits this bid in strict accordance with said Invitation for Bids. Bidder has carefully checked all words and figures shown on this Bid Form and has carefully reviewed the accuracy of all documents, representations, manufacturer's literature, and statements submitted with this bid.

Bidder understands that this bid constitutes a firm offer to the District that cannot be withdrawn for ninety (90) calendar days from the date of bid opening. If awarded the contract, bidder agrees to deliver to the District executed copies of the final contract and required insurance certificates within ten (10) calendar days of the date of the District Notice of Award. Said Notice of Award shall be deemed duly given to Bidder upon delivery if delivered by hand, or three (3) calendar days after posting if sent by mail to Bidder's address.

Bidder understands that no partial, conditional or qualified bids shall be accepted for any bid item. Bidder further understands the right of the District Board of Directors to accept or reject any or all bids received for any reason. The District reserves the right to waive minor irregularities.

The contract, if awarded, will be to the lowest responsive, responsible bidder. Bidder understands that the "lowest responsible bidder" is the lowest bidder whose offer best responds in quality, fitness and capacity to the requirements of the Invitation for Bids. The District reserves the right to award to other than the lowest bidder if the District finds that the lowest bidder is not responsible.

Bidder acknowledges receipt of the following addenda to the Invitation for Bids. All cost adjustments or other requirements resulting from said addenda have been taken into consideration by the bidder and included in the bid.

Addenda No.'s _____

Bidder has submitted the following documents with the bid:

1. Exceptions, if any, taken to the specifications or other sections of the IFB. (Warning: Substantive exceptions will be cause for bid rejection.)
2. Copy of any standard warranties in accordance with the Specifications.
3. Bidder's Security
4. Fully executed copy of the "Lobbying Certification" listed as Page I-4 of the Bid, if applicable
5. Fully executed copy of the "Buy America Provision Certification" listed as Page I-5 of the Bid, if applicable.

Bidder understands that bids shall be placed in a sealed envelope marked as indicated below and delivered to the Santa Cruz Metropolitan Transit District, 370 Encinal Street, Suite 100, Santa Cruz, California, 95060 prior to the time of bid opening. Bids postmarked before bid opening but delivered afterward shall be rejected.

IFB No. 09-01
"Demolition of Old Bus Wash Area"
Bid Opening 2:00 p.m., December 5, 2008

Bidder has full power and authority to enter into and perform the work described in the Invitation for Bids on behalf of the company noted below

Company Name

Indicate:

Sole Proprietorship Partnership Corporation

Joint Venture with _____

Street Address

City, State, Zip Code

Signature of authorized company official

Typewritten name of above and title

Name, title, and email address of person to whom correspondence should be directed

Telephone Number

FAX Number

Date

Federal Tax ID No.

The Santa Cruz Metropolitan Transit District is a special purpose District and is a subdivision of the State of California.

**CERTIFICATION OF PROPOSED CONTRACTOR REGARDING DEBARMENT,
SUSPENSION AND OTHER INELIGIBILITY AND VOLUNTARY EXCLUSION**

(Contractor) _____ certifies to the best of its knowledge and belief, that it and its principals:

Are not presently debarred, suspended, proposed for debarment, declared ineligible or voluntarily excluded from covered transactions by any Federal department or agency;

Have not within a three year period preceding this bid been convicted of or had a civil judgment rendered against them for commission of fraud or a criminal offense in connection with obtaining, attempting to obtain or performing a public (Federal, State, or local) transaction or contract under a public transaction; violation of Federal or State antitrust statutes or commission of embezzlement, theft, forgery, bribery, falsification or destruction of records, making false statements or receiving stolen property;

Are not presently indicted for or otherwise criminally or civilly charged by a governmental entity (Federal, State or local) with commission of any of the offenses enumerated in paragraph (2) of this certification; and

Have not within a three year period preceding this bid had one or more public transactions (Federal, State or local) terminated for cause or default.

If the Proposed Subcontractor is unable to certify to any of the statements in this certification, it shall attach an explanation to this certification.

(Contractor) _____, CERTIFIES OR AFFIRMS THE TRUTHFULNESS AND ACCURACY OF THE CONTENTS OF THE STATEMENTS SUBMITTED ON OR WITH THIS CERTIFICATION AND UNDERSTANDS THAT THE PROVISIONS OF 31 U.S.C. SECTIONS 3801 ET. SEQ. ARE APPLICABLE THERETO.

Signature and Title of Authorized Official

LOBBYING CERTIFICATION
(Only for Contracts above \$100,000)

Lobbying Certification for Contracts Grants, Loans and Cooperative Agreements (Pursuant to 49 CFR Part 20, Appendix A)

The undersigned certifies, to the best of his or her knowledge and belief, that:

- (1) No Federal appropriated funds have been paid or will be paid, by or on behalf of the undersigned, to any person for influencing or attempting to influence an officer or employee of an agency, a Member of Congress, an officer or employee of Congress, or an employee of a Member of Congress in connection with the awarding of any Federal Contract, the making of any Federal grant, the making of any Federal loan, the entering into of any cooperative agreement, and the extension, continuation, renewal, amendment, or modification of any Federal Contract, grant, loan, or cooperative agreement.
- (2) If any funds other than Federal appropriated funds have been paid or will be paid to any person for making lobbying contacts to an officer or employee of any agency, a Member of Congress, an officer or employee of Congress, or an employee of a Member of Congress in connection with this Federal Contract, grant, loan, or cooperative agreement, the undersigned shall complete and submit Standard Form--LLL, "Disclosure Form to Report Lobbying," in accordance with its instructions and as amended by "Government wide Guidance for New Restrictions on Lobbying," 61 Fed. Reg. 1413 (1/19/96).
- (3) The undersigned shall require that the language of this certification be included in the award documents for all sub awards at all tiers (including subcontracts, sub grants, and Contracts under grants, loans, and cooperative agreements) and that all sub recipients shall certify and disclose accordingly.

This certification is a material representation of fact upon which reliance was placed when this transaction was made or entered into. Submission of this certification is a prerequisite for making or entering into this transaction imposed by 31 U.S.C. § 1352 (as amended by the Lobbying Disclosure Act of 1995). Any person who fails to file the required certification shall be subject to a civil penalty of not less than \$10,000 and not more than \$100,000 for each such failure.

The Bidder/Offeror certifies or affirms the truthfulness and accuracy of each statement of its certification and disclosure, if any. In addition, the Bidder/Offeror understands and agrees that the provisions of 31 U.S.C. A 3801, et. seq. apply to this certification and disclosure, if any.

Firm Name _____

Signature of Authorized Official _____

Name and Title of Authorized Official _____

Date _____

**BUY AMERICA PROVISION
(Only for Contracts above \$100,000)**

This procurement is subject to the Federal Transit Administration Buy America Requirements in 49 CFR part 661.

A Buy American Certificate, as per attached format, must be completed and submitted with the bid. A bid which does not include the certificate will be considered non-responsive.

A false certification is a criminal act in violation of 18 U.S.C. 1001. Should this procurement be investigated, the successful bidder/proposer has the burden of proof to establish that it is in compliance.

A waiver from the Buy America Provision may be sought by SCMID if grounds for the waiver exist.

Section 165(a) of the Surface Transportation Act of 1982 permits FTA participation on this contract only if steel and manufactured products used in the contract are produced in the United States.

BUY AMERICA CERTIFICATE

The bidder hereby certifies that it will comply with the requirements of Section 165(a) or (b) (3) of the Surface Transportation Assistance Act of 1982, and the applicable regulations in 49 CFR Part 661.

Date: _____

Signature: _____

Company Name: _____

Title: _____

OR

The bidder hereby certifies that it cannot comply with the requirements of Section 165(a) or (b) (3) of the Surface Transportation Act of 1982, but may qualify for an exception to the requirement pursuant to Section 165(b)(2) or (b)(4) of the Surface Transportation Assistance Act of 1982, as amended, and regulations in 49 CFR 661.7.

Date: _____

Signature: _____

Company Name: _____

Title: _____

BIDDER DBE INFORMATION

BIDDER'S NAME _____
 DBE GOAL FROM CONTRACT _____ %
 FED. NO. _____
 COUNTY _____
 AGENCY _____
 CONTRACT NO. _____

BIDDER'S ADDRESS _____

 BID AMOUNT \$ _____
 BID OPENING DATE _____
 DATE OF DBE CERTIFICATON _____
 SOURCE ** _____

This information must be submitted during the initial negotiations with the District. By submitting a proposal, offeror certifies that he/she is in compliance with the District's policy. Failure to submit the required DBE information by the time specified will be grounds for finding the bid or proposal non-responsive.

CONTRACT ITEM NO.	ITEM OF WORK AND DESCRIPTION OF WORK OR SERVICES TO BE SUBCONTRACTED OR MATERIALS TO BE PROVIDED *	CERTIFICATION FILE NUMBER	NAME OF DBE	DOLLAR AMOUNT DBE ***	PERCENT DBE

TOTAL CLAIMED DBE
 PARTICIPATION \$ _____ %

SIGNATURE OF BIDDER

DATE

AREA CODE/TELEPHONE

(Detach from proposal if DBE information is not submitted with bid.)

- * If 100% of item is not to be performed or furnished by DBE, describe exact portion, including plan location of work to be performed, of item to be performed or furnished by DBE.
- ** DBE's must be certified on the date bids are opened.
- *** Credit for a DBE supplier who is not a manufacturer is limited to 60% of the amount paid to the supplier.

NOTE: Disadvantaged business must renew their certification annually by submitting certification questionnaires in advance of expiration of current certification. Those not on a current list cannot be considered as certified.

BIDDER DBE INFORMATION

CONTRACT ITEM NO.	ITEM OF WORK AND DESCRIPTION OF WORK OR SERVICES TO BE SUBCONTRACTED OR MATERIALS TO BE PROVIDED *	CERTIFICATION FILE NUMBER	NAME OF DBE	DOLLAR AMOUNT DBE ***	PERCENT DBE
----------------------	--	------------------------------	-------------	-----------------------------	----------------

TOTAL CLAIMED DBE PARTICIPATION \$ _____ %

PART II

INSTRUCTIONS TO BIDDERS

1. **CONTENTS:** This Invitation for Bids (IFB) includes the (I) Bid Form, (II) Instructions to Bidders, (III) Specifications, (IV) General Conditions of the Contract, (V) Special Conditions of the Contract, (VI) Contract, (VII) FTA Requirements for Non-Construction Contracts, and (VIII) Formal Bidding Procedures. The final Contract with the Successful Bidder will be in the form and substance of the Contract (Part VI) included in the IFB.
2. **SUBMISSION OF BID:** Prior to the date and time of bid opening, all bids shall be delivered to the District at 370 Encinal Street, Suite 100, Santa Cruz, California, 95060. All bids shall be in a sealed envelope properly endorsed as to name and opening date. No bids received after said time or at any place other than the place as stated in the Notice and Invitation to Bidders will be considered. For example, bids postmarked before bid opening but received after shall be rejected. Telephone or electronic bids will not be accepted.
3. **BIDDER RESPONSIBILITY:** The District has made every attempt to provide all information needed by bidders for a thorough understanding of project terms, conditions and other requirements. It is expressly understood that it is Bidder's responsibility to examine and evaluate the work required under this Invitation for Bids (IFB) and the terms and conditions under which the work is performed. By submitting a bid, Bidder represents that it has investigated and agrees to all the terms and conditions of the IFB.
4. **BID FORM:** The bid shall be made on the Bid Form provided therefore and shall be enclosed in a sealed envelope marked and addressed as required. If the bid is made by a sole proprietor, it shall be signed with his/her full name and his address shall be given; if it is made by a partnership, it shall be signed with the co-partnership name by a member of the firm, who shall also sign his/her own name, and the name and address of each member shall be given; and if it is made by a corporation, it shall be signed by an officer or other individual who has the full and proper authorization to do so.

When the Bid Form is signed by an agent, other than the officer or officers of a corporation authorized to sign Contracts on its behalf, or is signed by an agent other than a partner of a partnership, or by an agent for an individual, a power of attorney must be submitted with the bid; otherwise, the bid will be rejected as irregular and unauthorized.

Blank spaces in the Bid Form shall be properly filled. The phraseology of the Bid Form must not be changed, and no additions shall be made to the items mentioned therein. Alterations by erasure or interlineations must be explained or noted in the bid over the signature of the Bidder. If the unit price and the total amount named by a Bidder for any item do not agree, the unit price alone will be considered as representing the Bidder's intention.

Submission of alternative bid or bids, except as specifically called for in the IFB, will render it informal and may cause its rejection.

5. **COMPETITIVE BIDDING:** If more than one bid is offered by any individual, firm, partnership, corporation, association, or any combination thereof, under the same or different names, all such bids may be rejected. A party who has quoted prices on materials or work to a Bidder is not thereby disqualified from quoting prices to other Bidders, or from submitting a bid directly for the materials or work if otherwise qualified to do so.

All Bidders are put on notice that any collusive agreement fixing the prices to be bid so as to control or affect the awarding of this Contract is in violation of the District's competitive bidding requirements and may render void any Contract let under such circumstances.

6. **EXPENSES TO BE INCLUDED IN BID PRICE:** Unless otherwise specified in the IFB, the bid price shall include all expenses necessary that go into making the items procured under the IFB complete and ready for immediate use by the District without additional expense. Bid price shall include, without limitation, all costs for labor, services, equipment, materials, supplies, transportation, installation, overhead, packing, cartage, insurance, license, fees, taxes, permits, bonds, inspection, and other expenses necessary to satisfy the provisions of the IFB, expressed and implied.

Unless bidder is specifically instructed to do otherwise in the Specifications section of this IFB, sales taxes shall be included in the bid price in the amount of 8.25 % of the total bid price. Federal Excise Tax, from which the District is exempt, should not be included in the bid price. A Federal Excise Tax Exemption certificate will be furnished to the successful Bidder.

Samples of items, when required, must be furnished free of expense to the District and, if not destroyed by tests may, upon request made at the time the samples are furnished, be returned at Bidder's expense.

7. **WITHDRAWAL OF BID:** Bidder may withdraw the bid before the expiration of the time during which bids may be submitted, without prejudice, by submitting a written request for its withdrawal to the District Secretary/General Manager.
8. **TIME OF DELIVERY:** Time of delivery is part of the bid and must be strictly adhered to by the Bidder. Bidder obligates itself to complete the work within the number of days specified in the Contract.
9. **CANVASS OF BID:** At the hour specified in the Notice of Invitation to Bidders, the District, in open session, will open, examine and publicly declare all bids received and shall announce each bidder's price. The remaining content of the bids shall not be made public until after an award is made by the Board of Directors or District Staff as appropriate. Bidders, their representatives and others interested, are invited to be present at the opening of bids. Award will be made or bids rejected by the District within the time period specified in the Bid, if none is specified, within sixty (60) days after the date of bid opening.
10. **RIGHT TO REJECT BIDS:** The District may reject any and all bids at its discretion, and may reject the bid of any party who has been delinquent or unfaithful in any former contract with the District. The right is reserved to reject any or all bids and to waive technical defects, as the interest of the District may require. The District may reject bids from Bidders who cannot satisfactorily prove the experience and qualifications outlined in the Instructions to Bidders.
11. **SINGLE BID:** If only one bid is received in response to the IFB, Bidder may be required to submit to District within five (5) days of District demand, a detailed cost proposal. The District may conduct a cost or price analysis of the cost proposal to determine if the bid price(s) are fair and reasonable. Bidder shall cooperate with District in compiling and submitting detailed information for the cost and price analysis.
12. **EXPERIENCE AND QUALIFICATIONS:** The Bidder may be required upon request of the District to prove to the District's satisfaction that the Bidder is responsible. Criteria used by the District to determine Bidder responsibility includes, without limitation, whether Bidder and its proposed contractors have the skill, experience, necessary facilities and financial resources to perform the Contract in a satisfactory manner and within the required time. Other criteria include whether the original equipment manufacturer of the items bid (1) has in operation, or has the capability to have in operation, a manufacturing plant adequate to assure delivery of all equipment within the time specified under the Contract and (2) has adequate engineering and service personnel, or has the capability to have such personnel, to satisfy any engineering or service problems that may arise during the warranty period and the useful life of all items bid. To help the District assess Bidder's responsibility and ability to provide continued parts, service, and engineering support for the useful life of all items bid, Bidder may be required to submit, at its own cost, its latest Dunn & Bradstreet report and its latest independently audited financial statements.
13. **APPROVED EQUALS:** In order to establish a basis of quality, certain items or processes may be specified by description or brand name. Unless otherwise specified, it is not the intent of the IFB to exclude other items or processes of equal value, utility or merit.

Bids for equivalent items meeting the standards of quality thereby indicated will be considered provided they are received by no later than fourteen calendar days before the date of bid opening. Any such bid shall include adequate information and samples, including technical data, test results, performance characteristics, life-cycle costs, and other salient characteristics to clearly describe the item or process offered and how it equals or exceeds the characteristics of the referenced brand or process.

Unless the Bidder clearly indicates otherwise in the bid, it is understood that he/she is offering a referenced brand or process as specified herein. The District reserves the right to determine whether a substitute offer is equivalent to, and meets the standards of, quality indicated by the brand name or process referenced.

14. **AWARD OF CONTRACT:** The award of the Contract, if awarded, will be to the responsive, responsible Bidder whose bid complies with the IFB in all respects, and whose ADJUSTED BID PRICE is the lowest of all qualified bids received. The methodology for determining the adjusted bid price is described in the Bid Form (Part I of the IFB). If the lowest responsive, responsible Bidder refuses or fails to execute the Contract, the District may award the Contract to the next lowest responsive, responsible Bidder or solicit new bids.
15. **EXECUTION OF CONTRACT:** The Contract shall be provided by the District in substantially the same form as provided in Part VI and shall be executed by the successful Bidder and returned to the District's Purchasing Office no later than ten (10) calendar days after the date of receipt of the Notice of Award. Successful Bidder shall submit the required insurance certificate(s) no later than ten (10) days after receipt of Notice of Award. Successful Bidder's execution and delivery of the insurance certificate(s) specified in the IFB is a condition precedent to the finalization of the Contract. In no event shall the successful Bidder commence work until it has received the signed Contract and notification from the District that the required insurance certificate(s) have been approved.
16. **ERRORS AND ADDENDA:** If omissions, discrepancies, or apparent errors are found in the IFB prior to the date of bid opening, the Bidder shall request a clarification from the District which, if substantiated, will be given in the form of addenda to all Bidders.
17. **NON-DISCRIMINATION:** The Santa Cruz Metropolitan Transit District will not discriminate with regard to race, color, ancestry, national origin, religion, sex, sexual orientation, marital status, age, medical condition or disability in the consideration for an award.
18. **DISADVANTAGED AND BUSINESS ENTERPRISES:** The Board of Directors of the Santa Cruz Metropolitan Transit District has adopted a Disadvantaged Business Enterprise Policy to promote the participation of disadvantaged business enterprises (DBE) in all areas of District contracting to the maximum extent practicable. Consistent with the DBE Policy, the Bidder shall take all necessary and reasonable steps to ensure that DBE firms have the maximum practicable opportunity to participate in the performance of this project and any subcontracting opportunities thereof.
19. **INQUIRIES AND CORRESPONDENCE DURING BIDDING PERIOD:** Written questions pertaining to the specifications, work requirements, terms, conditions and the bid documents during the bidding period shall be directed to the District Buyer at 370 Encinal Street, Suite 100, Santa Cruz, CA 95060 or his email address is: llongnecker@scmtd.com.
20. **BIDDER'S SECURITY:** A bid guarantee is to be submitted with the bid in the amount of five percent (5%) of the bid price. The bid guarantee shall be in the form of a cashier's or certified check; a bid bond, or an irrevocable letter of credit.
21. **PERFORMANCE AND PAYMENT BONDS:** A Performance Bond in the amount of 100% of the total Contract price, as awarded by the District shall be provided within ten (10) days after notice of award. Said bond shall guarantee the Contractor's faithful performance of the Contract and compliance with all terms, conditions and requirements specified in the Contract Documents and shall remain in full force and effect up to and including the date of the District's acceptance.

A Payment Bond shall be provided within ten (10) days after notice of award. Said bond shall assure payment, as required by law, of all persons supplying labor and material in the execution of work provided in the contract. Payment bond amounts required from Contractor are as follows:

- (1) 50% of the contract price if the contract price is not more than \$1 million;
 - (2) 40% of the contract price if the contract price is more than \$1 million but not more than \$5 million; or
 - (3) \$2.5 million if the contract price is more than \$5 million.
22. **PREVAILING WAGES:** Pursuant to Section 1773 of the Labor Code, the general prevailing rate of wages in the District has been determined by the Director of the Department of Industrial Relations, and such prevailing rate of wages is listed in the State of California, Department of Industrial Relations publication entitled General Prevailing Wage Rates, current edition, available by going to the world wide web at the following address:
<http://www.dir.ca.gov/dlsr/main.htm>.
23. No laborer employed directly upon the site of the work shall receive less than the prevailing wage rates as determined by the Director of the Department of Industrial Relations.

PART III

SPECIFICATIONS FOR DEMOLITION OF OLD BUS WASH AREA

GENERAL DESCRIPTION

Project will consist of the demolition and removal of structures and concrete located at 1200 River Street, Santa Cruz as per specifications, terms, and conditions contained in this IFB and attached drawings. The specifications described below set forth the minimum requirements for the quantity and quality of work to be provided hereunder. Contractor's bid shall meet or exceed the specifications attached hereto. As used herein, the term "work" refers to the articles, equipment, materials, supplies and labor as specified, designated or otherwise required by the Invitation for Bids (IFB). Additional terms, conditions and requirements pertaining to the methods and manner of performing the work are described elsewhere in the IFB.

IFB SCHEDULE.

The anticipated schedule of activities related to this IFB is as follows:

EVENT	DATE
Distribution of IFB	October 24, 2008
Pre-Bid Conference	November 5, 2008, 1:30 P.M.
Deadline for submission of written questions	November 14, 2008, 5:00 P.M.
METRO's response to written questions	November 19, 2008
Bid Due Date	December 5, 2008, 2:00 P.M.
METRO Board Approval Date	December 19, 2008
Contract Notice to Proceed	January 1, 2009
Completion of Demolition	January 31, 2009

SECTION 01100 - SUMMARY

PART 1 - GENERAL

1.01 RELATED DOCUMENTS

- A. Drawings and general provisions of the Contract, including General and Supplementary Conditions and other Division 1 Specification Sections, apply to this Section.

1.02 SUMMARY

- A. This Section includes the following:
 - 1. Work covered by Contract Documents.
 - 2. Contracts.
 - 3. Work sequence.
 - 4. Use of premises.
 - 5. Miscellaneous provisions.

1.03 WORK COVERED BY CONTRACT DOCUMENTS

- A. Project Identification: Project consists of **demolition and removal of old bus wash area which includes removal of structures, concrete and re-pave area with asphalt.**
 - 1. Project Location: **Old Bus Wash Area 1200 River Street, Santa Cruz, CA**

2. Owner: Santa Cruz Metropolitan Transit District (District)
- B. Architect Identification: The architect for this project is RNL Design, 800 Wilshire Blvd., Los Angeles, CA 90740
- C. Project Manager, **Frank Cheng, a full-time employee of District**, has been appointed by District to serve as Project Coordinator.
- D. The Work consists of a waste management plan, temporary fencing (which will remain beyond contract completion under a lease-transfer agreement to the District), removal of identified hazardous materials, demolition of above and below grade construction elements, capping in place of existing utilities, and sandbagging to prevent runoff of demolition-created exposed silt.
- 1 The Work includes:
- a. Temporary site fencing
 - b. Clearing of bus wash structure, canopy and related sheds.
 - c. Recommended removal of identified hazardous materials.
 - d. Preparation and execution of a waste management plan with goal to recycle/salvage 50% of the demolition volume.
 - e. Demolition of above and below grade structures.
 - f. Level Filling of demolished footprint and foundation-removal soil depressions with broken concrete to within 6" of the adjacent driving surfaces.
 - g. Removal from site of all salvage and demolition waste.
 - h. Re-pave demolition area with asphalt.

1.04 CONTRACT

- A. This demolition project will be performed under a construction contract (**SEE PART VI - CONTRACT FOR DEMOLITION SERVICES**)

1.05 WORK SEQUENCE

- A. The Work shall be conducted in a single phase.

1.06 USE OF PREMISES

- A. General: Contractor shall have coordinated use of premises for construction operations. Contractor's use of premises is limited only by District's right to perform work or to retain other contractors on portions of Project.

1.07 SPECIFICATION FORMATS AND CONVENTIONS

- A. Specification Format: The Specifications are organized into Divisions and Sections using portions of the 16-division format and CSI/CSC's "Master Format" numbering system.
- 1 Section Identification: The Specifications use section numbers and titles to help cross-referencing in the Contract Documents. Sections in the Project Manual are in numeric sequence; however, the sequence is incomplete. Consult the table of contents at the beginning of the Project Manual to determine numbers and names of sections in the Contract Documents.
- B. Specification Content: The Specifications use certain conventions for the style of language and the intended meaning of certain terms, words, and phrases when used in particular situations. These conventions are as follows:
1. Abbreviated Language: Language used in the Specifications and other Contract Documents is abbreviated. Words and meanings shall be interpreted as appropriate. Words implied, but not stated, shall be inferred as the sense requires. Singular words shall be interpreted as plural, and plural words shall be interpreted as singular where applicable as the context of the Contract Documents indicates.
 2. Imperative mood and streamlined language are generally used in the Specifications. Requirements expressed in the imperative mood are to be performed by Contractor. Occasionally, the indicative

or subjunctive mood may be used in the Section Text for clarity to describe responsibilities that must be fulfilled indirectly by Contractor or by others when so noted.

- a. The words "shall," "shall be," or "shall comply with," depending on the context, are implied where a colon (:) is used within a sentence or phrase

1.08 MISCELLANEOUS PROVISIONS - None

PART 2 - PRODUCTS (Not Used)

PART 3 - EXECUTION (Not Used)

END OF SECTION 01100

SECTION 02221 - SPECIFICATIONS FOR DEMOLITION OF BUS WASH AREA

PART 1 - GENERAL

1.01 RELATED DOCUMENTS

- A. Drawings and general provisions of the Contract, including General and Supplementary Conditions apply to this Section.

1.02 SUMMARY

- A. This Section includes the following:
 1. Demolition and removal of structures.
 2. Demolition and removal of limited site paving and concrete adjacent to structure to be demolished.
 3. Removing below-grade construction.
 4. Provide asphalt
 5. Disconnecting, capping or sealing, and abandoning in place site utilities.
- B. Related Sections include the following:
 1. Division 1 Section "Summary" for use of the premises and phasing requirements.
 2. Division 1 Section "Work Restrictions" for restrictions on use of the premises due to District or tenant occupancy of adjacent structures.
 3. Division 1 Section "Construction Progress Documentation" for pre-construction videotape taken before building demolition.
 4. Division 1 Section "Temporary Facilities and Controls" for temporary construction, protection facilities, and environmental-protection measures for building demolition operations.

1.03 DEFINITIONS

- A. Remove: Detach items from existing construction and legally dispose of them off-site unless indicated to be removed and salvaged or recycled.
- B. Remove and Salvage: Detach items from existing construction and deliver them offsite for resale or reuse.
- C. Existing to Remain: Existing items of construction that are not to be removed and that are not otherwise indicated to be removed, removed and salvaged, or recycled.
- D. Recycle: Recovery of demolition for subsequent delivery to agent for incorporation into future manufactured products.
- E. Salvage: Recovery of demolition for subsequent sale or reuse

1.04 MATERIALS OWNERSHIP

- A. Historic items, relics, and similar objects including, but not limited to, cornerstones and their contents, commemorative plaques and tablets, antiques, and other items of interest or value to District that may be encountered during building demolition remain District's property. Carefully remove and salvage each item or object in a manner to prevent damage and deliver promptly to District.
- B. All demolition materials not described in section A above become the property of the Contractor.

1.05 SUBMITTALS

- A. Qualification Data: For
 - 1. Demolition firm
- B. Proposed Environmental-Protection, Hazardous waste processing and Dust-Control Measures: Submit statement or drawing that indicates the measures proposed for use, proposed locations, and proposed time frame for their operation. Identify options if proposed measures are later determined to be inadequate.
- C. Waste Management Plan: Submit 3 copies of plan within 7 days of the date established for commencement of the work. Develop a Waste Management Plan with a goal that results in the end-of-project rates for salvage/recycling of 50 % by weight of total waste generated by the work. Plan to identify target materials and waste reduction and specify, before closeout, the following:
 - 1. Waste Reduction Calculations
 - 2. Records of Donations
 - 3. Records of Sales
 - 4. Recycling and Processing Facility Records
 - 5. Landfill Records
- D. Schedule of Building Demolition Activities: Indicate the following:
 - 1. Detailed sequence of Hazardous Material Removal work to be done prior to the beginning of the broader demolition and removal work, with starting and ending dates for each activity.
 - 2. Detailed sequence of demolition and removal work, with starting and ending dates for each activity.
 - 3. Coordination for shutoff, and capping, of utility services.
 - 4. Locations of temporary protection and means of egress, mindful of operations ongoing on adjacent sites.
- E. Inventory: After building demolition is complete, submit a list of items that have been removed, recycled, and salvaged.
- F. Pre-demolition Images: Show existing conditions of adjoining construction and site improvements, including finish surfaces that might be misconstrued as damage caused by building demolition operations. Submit before Work begins.
- G. Landfill Records: Indicate receipt and acceptance of hazardous wastes by a landfill facility licensed to accept hazardous wastes.

1.06 QUALITY ASSURANCE

- A. Demolition Firm Qualifications: An experienced firm that has specialized in demolition work similar in material and extent to that indicated for this Project.
- B. Regulatory Requirements: Comply with governing EPA notification regulations before beginning demolition. Comply with hauling and disposal regulations of authorities having jurisdiction.
- C. Standards: Comply with ANSI A10.6 and NFPA 241.
- D. Pre-demolition Conference: Conduct conference at Project site to comply with requirements in Division 1 Section "Project Management and Coordination."
- E. Pre-demolition Conference: Conduct conference at Project site to comply with requirements in Division 1 Section "Project Management and Coordination." Review methods and procedures related to building demolition including, but not limited to, the following:
 - 1. Inspect and discuss condition of construction to be demolished.
 - 2. Review structural load limitations of existing structures.

3. Review and finalize building demolition schedule and verify availability of demolition personnel, equipment, and facilities needed to make progress and avoid delays.
4. Review and finalize protection requirements.

1.07 PROJECT CONDITIONS

- A. Structures to be demolished will be vacated and their use discontinued before start of Work.
 1. Provide not less than 72 hours' notice to District of activities that may affect District's operations on adjacent sites
 2. Maintain access to existing walkways, exits, and other adjacent occupied or used facilities.
 - a. Do not close or obstruct walkways, exits, or other occupied or used facilities without written permission from authorities having jurisdiction.
- B. District assumes no responsibility for buildings and structures to be demolished.
 1. Conditions existing at time of inspection for bidding purpose will be maintained by District as far as practical.
- C. Hazardous Materials: If materials suspected of containing hazardous materials are encountered, do not disturb; immediately notify Project Manager. As yet unidentified and newly discovered hazardous materials will be removed by District under a separate contract or by change order negotiated with this contractor at District's option.
- D. Storage or sale of removed items or materials on-site is not permitted.

1.08 COORDINATION

- A. Coordinate demolition schedule so as not to interfere with District's operations on the property.

PART 2 - EXECUTION

2.01 EXAMINATION

- A. Survey existing conditions and correlate with requirements indicated to determine extent of building demolition required.
- B. Review Project Record Documents as available through City and County records of existing construction. District does not guarantee that existing conditions are the same as those indicated in available public records.
- C. Inventory and record the condition of items to be removed and salvaged.
- D. When unanticipated mechanical, electrical, or structural elements are encountered, investigate and measure the nature and extent of the element. Promptly submit a written report to the METRO.
- E. Engage a professional engineer to perform an engineering survey of condition of building to determine whether removing any element might result in structural deficiency or unplanned collapse of any portion of structure or adjacent structures during building demolition operations.
- F. Verify that hazardous materials have been remediated before proceeding with building demolition operations.

2.02 PREPARATION

- A. Existing Utilities: Locate, identify, disconnect, and seal or cap off indicated utilities serving buildings and structures to be demolished.
 1. District will arrange to shut off indicated utilities when requested by Contractor.
 2. If utility services are required to be removed, relocated, or abandoned, before proceeding with demolition provide temporary utilities that bypass buildings and structures to be demolished and that maintain continuity of service required.
 3. Cut off pipe or conduit a minimum of 24 inches below grade. Cap, valve, or plug and seal remaining portion of pipe or conduit after bypassing per City standards.

- B. Existing Utilities: Do not start demolition work until utility disconnecting and sealing have been completed and verified in writing.
- C. Temporary Shoring: Provide and maintain interior and exterior shoring, bracing, or structural support to preserve stability and prevent unexpected movement or collapse of construction being demolished.
 - 1. Strengthen or add new supports when required during progress of demolition.

2.03 PROTECTION

- A. Existing Facilities: Protect adjacent drainage channels, surface drain grates, walkways and driving surfaces (to remain) from break up during the demolition and removal process
- B. Existing Items to Remain: Protect construction indicated to remain against damage during demolition
- C. Temporary Protection: Erect temporary protection, such as walks, fences, railings, canopies, and covered passageways, where required by authorities having jurisdiction and as indicated. Comply with requirements in Division 1 Section "Temporary Facilities and Controls."
 - 1. Protect existing site improvements, and appurtenances to remain.
 - 2. Provide temporary barricades and other protection required to prevent injury to people and damage to facilities to remain.
 - 3. Provide protection to ensure safe passage of people around building demolition area and to and from occupied portions of adjacent buildings and structures.
 - 4. Erect and maintain dustproof partitions and temporary enclosures to limit dust and dirt migration and to separate areas from fumes and noise from occupied portions of adjacent buildings.

2.04 DEMOLITION, GENERAL

- A. General: Demolish indicated existing structures completely. Use methods required to complete the Work within limitations of governing regulations and as follows:
 - 1. Do not use cutting torches until work area is cleared of flammable materials. Maintain fire watch and portable fire-suppression devices during flame-cutting operations.
 - 2. Maintain adequate ventilation when using cutting torches.
- B. Engineering Surveys: Perform surveys as the Work progresses to detect hazards that may result from building demolition activities.
- C. Site Access and Temporary Controls: Conduct building demolition and debris-removal operations to ensure minimum interference with roads, streets, walks, walkways, and other adjacent occupied and used facilities
 - 1. Do not close or obstruct streets, walks, walkways, or other adjacent occupied or used facilities without permission from District and authorities having jurisdiction. Provide alternate routes around closed or obstructed traffic ways if required by authorities having jurisdiction.
 - 2. Use water mist and other suitable methods to limit spread of dust and dirt. Comply with governing environmental-protection regulations. Do not use water when it may damage adjacent construction or create hazardous or objectionable conditions, such as ice, flooding, and pollution.

2.05 MECHANICAL DEMOLITION

- A. Remove structures intact when permitted by authorities having jurisdiction.
- B. Proceed with demolition of structural framing members systematically, from higher to lower level. Complete building demolition operations above each floor or tier before disturbing supporting members on the next lower level.
- C. Remove debris from elevated portions by chute, hoist, or other device that will convey debris to grade level in a controlled descent.
 - 1. Remove structural framing members and lower to ground by method suitable to minimize ground impact or dust generation
- D. Concrete: Cut concrete full depth at junctures with construction indicated to remain, using power-driven saw, then remove concrete between saw cuts.

- E. Masonry: Cut masonry at junctures with construction indicated to remain, using power-driven saw, then remove masonry between saw cuts.
- F. Concrete Slabs-on-Grade: Saw-cut perimeter of area to be demolished at junctures with driving surfaces indicated to remain, then break up and remove. Driving surfaces may be over cut beyond building lines sufficient distance to allow removal of footing material without undercutting the paved surfaces above.
- G. Structural Steel: Dismantle field connections without bending or damaging steel members. Do not use flame-cutting torches unless otherwise authorized by authorities having jurisdiction.
 - 1. Transport steel trusses and joists as whole units without dismantling them further.
- H. Equipment: Disconnect equipment at nearest fitting connection to services, complete with service valves. Remove as whole units, complete with controls.
- I. Below-Grade Construction: Demolish below-grade construction that is within 5 feet outside of the structure footprint. Abandon below-grade construction outside this area.
 - 1. Remove below-grade construction, including foundation walls, and footings, completely
- J. Existing Utilities: Abandon existing utilities and below-grade utility structures in place, capping per City Standards.
 - 1. Fill abandoned utility structures with satisfactory soil materials or recycled pulverized concrete according to City Standards.
 - 2. Piping: Disconnect piping at unions, flanges, valves, or fittings.
 - 3. Wiring Ducts: Disassemble into unit lengths and remove plug-in and disconnecting devices.

2.06 EXPLOSIVE DEMOLITION

- A. Explosives: Use of explosives is **not** permitted.

2.07 SITE RESTORATION

- A. Below-Grade Areas: Rough grade below-grade areas ready for further excavation or new construction.
- B. Below-Grade Areas: Completely fill below-grade areas and voids resulting from structure demolition operations with recycled pulverized concrete to a depth not greater than 6" below adjacent paved surfaces.

2.08 REPAIRS

- A. General: Promptly repair damage to adjacent construction caused by demolition operations.
- B. Where repairs to existing surfaces are required, patch to produce surfaces suitable for new materials.
- C. Restore exposed finishes of patched areas and extend restoration into adjoining construction in a manner that eliminates evidence of patching and refinishing.

2.09 RECYCLING DEMOLISHED MATERIALS

- A. General: Separate recyclable demolished materials from other demolished materials to the maximum extent possible. Separate recyclable materials by type.
 - 1. Provide containers or other storage method for controlling recyclable materials until they are removed from Project site.
 - 2. Stockpile processed materials on-site without intermixing with other materials. Place, grade, and shape stockpiles to drain surface water. Cover to prevent windblown dust.
 - 3. Stockpile materials away from demolition area.
 - 4. Store components off the ground and protect from the weather.
 - 5. Transport recyclable materials off District's property and legally dispose of them
- B. Recycling Incentives: Revenues, savings, rebates, tax credits, and other incentives received for recycling building demolition materials shall accrue to Contractor.
- C. Asphalt: Break up and transport asphalt to asphalt recycling facility.
- D. Concrete: Remove reinforcement and other metals from concrete and sort with other metals. Pulverize concrete to maximum 4-inch size.

- E. Masonry: Remove metal reinforcement, anchors, and ties from masonry and sort with other metals.
 - 1. Pulverize masonry to maximum 4-inch size.
 - 2. Clean and stack undamaged, whole masonry units on wood pallets.
- F. Wood Materials: Sort and stack members according to size, type, and length. Separate dimensional and engineered lumber, panel products, and treated wood materials.
- G. Metals: Separate metals by type.
 - 1. Structural Steel: Stack members according to size, type of member, and length.
 - 2. Remove and dispose of bolts, nuts, washers, and other rough hardware.
- H. Equipment: Drain tanks, piping, and fixtures. Seal openings with caps or plugs.
- I. Piping: Reduce piping to straight lengths and store by type and size. Separate supports, hangers, valves, sprinkler heads, and other components by type and size.
- J. Lighting Fixtures: Separate lamps by type and protect from breakage.
- K. Electrical Devices: Separate switches, receptacles, switchgear, transformers, meters, panelboards, circuit breakers, and other devices by type.
- L. Conduit: Reduce conduit to straight lengths and store by type and size.

2.10 DISPOSAL OF DEMOLISHED MATERIALS

- A. General: Except for items indicated to be recycled, or otherwise indicated to remain District's property, remove demolished materials from Project site and legally dispose of them in an EPA-approved landfill.
 - 1. Do not allow demolished materials to accumulate on-site.
 - 2. Remove and transport debris in a manner that will prevent spillage on adjacent surfaces and areas.
- B. Burning: Do not burn demolished materials.
- C. Clean adjacent structures and improvements of dust, dirt, and debris caused by building demolition operations. Return adjacent areas to condition existing before building demolition operations began.

END OF SECTION 02221

SECTION 02740 - FLEXIBLE PAVEMENT

PART 1 - GENERAL

1.01 RELATED DOCUMENTS

- A. Drawings and general provisions of the Contract, including Invitation For Bids (IFB) and other Division 1 Specification Sections, apply to this Section.

1.02 SUMMARY

- A. This Section includes the following:
 - 1. Provide asphalt concrete paving for the following applications:
 - a. On-site asphalt concrete parking areas.
 - b. Off-site roadway asphalt concrete overlays.
 - c. Off-site roadway asphalt concrete pavement patches and repairs.
 - d. Asphalt concrete access roadways.
 - e. Pavement repair at excavations for trenches.

1.03 REFERENCES

- A. Caltrans Standard Specifications, 2002 Edition, Section 39, "Asphalt Concrete", Section 84-3, "Painted Stripes and Pavement Markings", Section 88, "Engineering Fabrics", and Section 92, "Asphalts," excepting the Measurement and Payment sections contained therein.
- B. City of Santa Cruz Standard Specifications, Technical Provisions, Section 12: Construction of Streets.

1.04 MEASUREMENT AND PAYMENT

- A. Full compensation for furnishing all labor, materials, tools, equipment and incidentals, and for doing all the work involved in constructing vehicular asphalt concrete paving work including materials, pavement cutting, placement and compaction of aggregate base course, and asphalt concrete installation as shown in the plans, as described herein, as specified by these specifications and as directed by the District shall be considered as included in the unit price paid for vehicular asphalt concrete pavement and no additional compensation will be allowed therefore.
- B. Full compensation for furnishing all labor, materials, tools, equipment and incidentals, and for doing all the work involved in constructing asphalt concrete overlays work including materials and asphalt concrete installation as shown in the plans, as described herein, as specified by these specifications and as directed by the District shall be considered as included in the unit price paid for asphalt concrete overlay and no additional compensation will be allowed therefores.

1.05 SUBMITTALS

- A. Asphalt concrete mix designs.
- B. Certificate of compliance with Caltrans specifications if requested by Owner's Representative.
- C. In the case of work within the City of Santa Cruz Right-Of-Way, aggregate samples shall be submitted to the City Engineer for testing and approval prior to use.

1.06 REGULATORY REQUIREMENTS

- A. All work, material, procedures and practices under this section shall conform to requirements of the California Air Resources Board (CARB) and the Monterey Bay Unified Air Pollution Control District.

1.07 QUALITY ASSURANCE

- A. Provide products of acceptable manufacturers, which have been in satisfactory use in similar service for at least three years.
- B. Use only experienced workers and installers.
- C. Deliver, handle, and store materials in accordance with manufacturer's instructions.
- D. Water test completed pavement.
 - 1. Pavement shall drain without the formation of puddles or birdbaths. Remove and replace pavement that does not comply.

PART 2 - PRODUCTS

2.01 MATERIALS

- A. The asphalt concrete shall conform to the following requirements:
 - 1. Asphalt concrete shall be Type B in conformance with the provisions in the Caltrans Standard Specifications, 2002 Edition, Section 39, "Asphalt Concrete," and these special provisions.
 - 2. The aggregate for Type B asphalt concrete shall conform to the 1/2" maximum, medium grading specified in the Caltrans Standard Specifications, 2002 Edition, Section 39-2 02, "Aggregate," and these special provisions. For work within the City of Santa Cruz Right-Of-Way, for surfaces greater than 2 inches in depth, the asphalt concrete shall be placed in two layers, the bottom layer of which may be 3/4" maximum aggregate. It shall conform to medium grading.
 - 3. The asphalt content of the asphalt mixture will be determined in conformance with the requirements in California Test 379, or in conformance with the requirements in California Test 382.
 - 4. The spreading and compacting requirements of the Caltrans Standard Specifications, 2002 Edition, Section 39-6, "Spreading and Compacting," shall apply.

5. Asphalt concrete shall be produced at a central mixing plant.
 6. The amount of asphalt binder to be mixed with the aggregate shall be between 4 percent and 7 percent, by weight, of the dry aggregate.
- B. Paint binder (tack coat) shall be applied to existing surfaces to be surfaced and between layers of asphalt concrete, except when eliminated by the Engineer.
 - C. Paint binder (tack coat) shall be, at the option of the Contractor, either slow setting type asphaltic emulsion, rapid setting asphaltic emulsion or paving asphalt. Slow-setting type asphaltic emulsion and rapid setting asphaltic emulsion shall conform to the provisions in Section 39-4.02, "Prime Coat and Paint Binder (Tack Coat)," and the provisions in Section 94, "Asphaltic Emulsions," of the Standard Specifications. When paving asphalt is used for paint binder, the grade will be determined by the Engineer. Paving asphalt shall conform to the provisions in Section 39-4.02, "Prime Coat and Paint Binder (Tack Coat)," and the provisions in Section 92, "Asphalts," of the Standard Specifications.
 - D. Pavement reinforcing fabric, where called for on the plans, shall conform with Caltrans Standard Specifications, 2002 Edition, Section 39-4.03, "Pavement Reinforcing Fabric," and Section 88-1.02, "Pavement Reinforcing Fabric."
 - E. Prime coat of liquid asphalt, SC-70 or SC-250, shall be placed on aggregate base before placing asphalt concrete.
 - F. Seal Coat Materials shall conform to the requirements of the section entitled "Bituminous Seals" of the State Standard Specifications except as herein modified. The particular type of seal coat, size and amount of materials shall be as specified on the plans or special conditions.
 - G. Bituminous binder for the fog seal shall be S.S.I mixing type asphalt emulsion mixed with equal parts water by volume.

PART 3 - EXECUTION

3.01 PREPARATION

- A. Place asphalt concrete only during periods of fair weather when the free air temperature is above 50 deg F.

3.02 PAVEMENT SAW CUTTING

- A. Saw cut existing pavement in straight lines (using a concrete saw) to a minimum depth equal to or greater than one half the thickness thereof. Should voids develop under the existing pavements during construction, those affected pavements shall be neatly saw cut in straight lines and replaced after the voids have been filled.
- B. Any pavement damaged by demolition activities shall be saw cut and restored at the expense of the Contractor.

3.03 INSTALLATION

- A. Asphalt Concrete:
 1. Remove loose material from compacted base. Proof roll and check for areas requiring additional compaction. Spreading and compacting shall be performed by methods that will produce an asphalt concrete surfacing of uniform smoothness, texture and density, which does not allow water to pond. Report unsatisfactory conditions in writing to Owner's Representative.
 2. Apply prime coat to prepared base 24 hours before paving at a rate of 0.10 to 0.25 gallon per square yard.
 3. Apply tack coat to previous laid work not to receive pavement reinforcing fabric, and vertical surfaces at a rate of 0.05 to 0.15 gallon per square yard. Tack coat shall be applied uniformly and be allowed to cure before placement of asphalt concrete.
 4. Place asphalt concrete in maximum 3 lifts at minimum temperature of 250 degrees F in strips not less than 10 feet wide overlapping previous strips.
 5. Test in-place asphalt work for thickness and smoothness. Remove and replace defective work and

- patch to eliminate evidence of patching.
6. Begin rolling when pavement can withstand weight of roller. Roll while still hot to obtain maximum density and to eliminate roller marks. Finished pavement thickness shall be as shown on plans.
- B. Placing Asphalt Concrete Surfacing within the City Of Santa Cruz right-Of-Way.
1. The thickness of the asphalt concrete surfacing shown on the plans or standard detail shall be considered the minimum thickness to be applied at any point on the street and sufficient thickness must be allowed prior to compacting to provide the necessary thickness after compaction.
 2. Mixing, transporting, placing and compacting asphalt concrete surfacing shall conform to the requirements of Section 37 of the State Standard Specifications except as herein modified.
 3. The mixture shall be laid on a dry surface and never while it is raining. Unless permitted by the City Engineer, the mixture shall be spread by means of a mechanical self-powered paver with a tamping bar and distributing screws to provide a well distributed compacted surface.
 4. Sufficient personnel shall be provided so that irregularities can be filled and leveled to the satisfaction of the City Engineer. When permitted to spread asphalt concrete by hand, sufficient well equipped rakers and shovelers must be available to provide a level and uniform finished joint.
 5. The roller shall make its first pass with the heavy wheel forward whenever possible. The joint between strips of paving shall be rolled carefully to assure a uniform density at the finished joint.
 6. A Fog Seal shall be applied to all new plant-mixed surfaces.
- C. Paint Binder:
1. The area to which paint binder has been applied shall be closed to public traffic. Care shall be taken to avoid tracking binder material onto existing pavement surfaces beyond the limits of construction.
- D. Fog Seal:
1. A Fog Seal Coat shall be applied to all new asphalt concrete surfaces
 2. Apply fog seal at a temperature between 70°F and 130°F at a rate of 0.10 to 0.20 gallons per square yard to new asphalt concrete. Do not apply if weather conditions are unsuitable, or if atmospheric temperature is below 55°F. Protect work until seal has cured.
- E. Applying Seal Coats within the City of Santa Cruz Right-Of-Way:
1. Fog Seals to be applied to new asphalt concrete surfaces shall be applied in amounts approved by the City Engineer. The amounts of emulsified asphalt shall be approximately 0.035 gallons per square yard of surface for a total of 0.070 gallons of emulsion and water mixture per square yard of surfacing.
 2. All seal coats, including the Fog Seal, shall be applied in conformity with Section 37 of the State Standard Specification except as herein modified.
 3. Particular attention shall be given to the temperature of the existing surface to which the seal coat is to be applied. Seal coating shall not begin early in the morning when the pavement surface is cold without permission from the City Engineer. Care must be taken to assure immediate application of rock chips or sand after spreading the asphalt.
- F. Tolerances:
1. Flatness: Maximum variation of 1/4 inch, measured with a ten-foot straight edge.
 2. Compacted thickness: Within 1/4 inch.
 3. Variation from specified finished elevation: Within 1/2 inch.
 4. Pavement shall match existing at all patches and conforms.
 5. If the finished surface of the asphalt concrete does not meet the specified surface tolerances, the surfacing shall be brought within tolerance by either (1) abrasive grinding (with fog seal coat on the areas which have been ground), (2) removal and replacement or (3) placing an overlay of asphalt concrete. The method will be selected by the Engineer. The corrective work shall be at the Contractor's expense.
 6. If abrasive grinding is used to bring the finished surface to the specified surface tolerances, additional grinding shall be performed, as necessary, to extend the area ground in each lateral direction so that the lateral limits of grinding are at a constant offset from, and parallel to, the nearest lane line or pavement edge, and in each longitudinal direction so that the grinding begins and ends at lines normal to the pavement centerline, within any ground area. Ground areas shall

be neat rectangular areas of uniform surface appearance. Abrasive grinding shall conform to the provisions in the first paragraph and the last 4 paragraphs in Section 42 2.02, "Construction," of the Caltrans Standard Specifications, 2002 Edition.

END OF SECTION 02740

PART IV

GENERAL CONDITIONS TO THE CONTRACT

I. GENERAL PROVISIONS

1.01 Governing Law & Compliance with All Laws

This Contract is governed by and construed in accordance with the laws of California. Each party will perform its obligations hereunder in accordance with all applicable laws, rules, and regulations now or hereafter in effect.

1.02 Right to Modify Contract

District may extend the term of this Contract, expand the Scope of Work, or otherwise amend the Contract. Any such extension, expansion or amendment shall be effective only upon written agreement of the parties in accordance with Section 13.14.

2. TERMINATION

2.01 Termination for Convenience

2.01.01 The performance of Work under this Contract may be terminated by the District upon fifteen (15) days' notice at any time without cause for any reason in whole or in part, whenever the District determines that such termination is in the District's best interest.

2.01.02 Upon receipt of a notice of termination, and except as otherwise directed by the District, the Contractor shall: (1) stop work under the Contract on the date and to the extent specified in the notice of termination; (2) place no further orders or subcontracts for materials, services, or facilities, except as may be necessary for completion of such portion of the Work under the Contract as is not terminated; (3) terminate all orders and subcontracts to the extent that they relate to the performance of work terminated by the notice of termination; (4) assign to the District in the manner, at the time, and to the extent directed by the District all of the rights, title, and interest of the Contractor under the orders and subcontracts so terminated, in which case the District shall have the right, at its discretion, to settle or pay any or all claims arising out of the termination of such orders and subcontracts; (5) settle all outstanding liabilities and claims arising out of such termination or orders and subcontracts, with the approval or ratification of the District, to the extent the District may require, which approval or ratification shall be final for all the purposes of this clause; (6) transfer title to the District and deliver in the manner, at the time, and to the extent, if any, directed by District the fabricated or unfabricated parts, work in progress, completed work, supplies and other material produced as a part of, or acquired in connection with the performance of, the work terminated and the completed or partially completed plans, drawings, information and other property which, if the Contract had been completed, would have been required to be furnished to the District; (7) use its best efforts to sell, in the manner, at the time, to the extent, and at the price(s) directed or authorized by the District, any property of the types referred to above provided, however, that the Contractor shall not be required to extend credit to any purchaser, and may acquire any such property under the conditions prescribed by and at a price(s) approved by the District, and provided further, that the proceeds of any such transfer or disposition shall be applied in reduction of any payments to be made to the District to the Contractor under this Contract or shall otherwise be credited to the price or cost of the Work covered by this Contract or paid in such other manner as the District may direct; (8) complete performance of such part of the Work as shall not have been terminated by the notice of termination; and (9)

take such action as may be necessary, or as the District may direct, for the protection or preservation of the property related to this Contract which is in the possession of the Contractor and in which the District has or may acquire an interest

2.02 Termination for Default

2.02.01 The District may, upon written notice of default to the Contractor, terminate the whole or any part of this Contract if the Contractor: (1) fails to complete the Scope of Work within time period stated in the Specifications section of the IFB; (2) fails to perform any of the other provisions of the Contract; or (3) fails to make progress as to endanger performance of this Contract in accordance with its provisions.

2.02.02 If the Contract is terminated in whole or in part for default, the District may procure, upon such terms and in such manner as the District may deem appropriate, supplies or services similar to those so terminated. Without limitation to any other remedy available to the District, the Contractor shall be liable to the District for any excess costs for such similar supplies or services, and shall continue the performance of this Contract to the extent not terminated under the provisions of this clause.

2.02.03 If, after notice of termination of this Contract under the provisions of this clause, it is determined for any reason that the Contractor was not in default under the provisions of this clause, or that the default was excusable under the provisions of this clause, the rights and obligations of Contractor and District shall be considered to have been terminated pursuant to termination for convenience of the District pursuant to Article 2 01 from the date of Notification of Default.

2.03 No Limitation

The rights and remedies of the District provided in this Article 2 shall not be exclusive and are in addition to any other rights and remedies provided by law or under this Contract.

3. FORCE MAJEURE

3.01 General

Neither party hereto shall be deemed to be in default of any provision of this Contract, or for any failure in performance, resulting from acts or events beyond the reasonable control of such party. For purposes of this Contract, such acts shall include, but not be limited to, acts of God, civil or military authority, civil disturbance, war, strikes, fires, other catastrophes, or other "force majeure" events beyond the parties' reasonable control; provided, however, that the provisions of this Section 3 shall not preclude District from canceling or terminating this Contract (or any order for any product included herein), as otherwise permitted hereunder, regardless of any force majeure event occurring to Contractor.

3.02 Notification by Contractor

Contractor shall notify District in writing as soon as Contractor knows, or should reasonably know, that a force majeure event (as defined in Section 3.01) has occurred that will delay completion of the Scope of Work. Said notification shall include reasonable proofs required by the District to evaluate any Contractor request for relief under this Article 3. District shall examine Contractor's notification and determine if the Contractor is entitled to relief. The District shall notify the Contractor of its decision in writing. The District's decision regarding whether or not the Contractor is entitled to force majeure relief shall be final and binding on the parties.

3.03 Losses

Contractor is not entitled to damages, compensation, or reimbursement from the District for losses resulting from any "force majeure" event.

4 PROFESSIONAL STANDARDS

Contractor shall at all times during the term of this Contract possess the technical ability, experience, financial ability, overall expertise, and all other skills, licenses, and resources necessary to perform and complete the scope of work in a timely, professional manner so as to meet or exceed the provisions of this Contract.

5 PROFESSIONAL RELATIONS

5.01 Independent Contractor

No relationship of employer and employee is created by this Contract. In the performance of its work and duties, Contractor is at all times acting and performing as an independent contractor in the practice of its profession. District shall neither have nor exercise control or direction over the methods by which Contractor performs services pursuant to this Contract (including, without limitation, its officers, shareholders, and employees); provided, however, that Contractor agrees that all work performed pursuant to this Contract shall be in strict accordance with currently approved methods and practices in its profession, and in accordance with this Contract. The sole interest of District is to ensure that such services are performed and rendered in a competent and cost effective manner.

5.02 Benefits

Contractor (including, without limitation, its officers, shareholders, subcontractors and employees) has no claim under this Contract or otherwise against the District for social security benefits, workers' compensation benefits, disability benefits, unemployment benefits, vacation pay, sick leave, or any other employee benefit of any kind.

6 INDEMNIFICATION FOR DAMAGES, TAXES AND CONTRIBUTIONS

6.01 Scope

Contractor shall exonerate, indemnify, defend, and hold harmless District (which for the purpose of Articles 6 and 7 shall include, without limitation, its officers, agents, employees and volunteers) from and against:

6.01.01 Any and all claims, demands, losses, damages, defense costs, or liability of any kind or nature which District may sustain or incur or which may be imposed upon it for injury to or death of persons, or damage to property as a result of, or arising out of, or in any manner connected with the Contractor's negligence, recklessness or willful misconduct under the provisions of this Contract. Such indemnification includes any damage to the person(s) or property(ies) of Contractor and third persons.

6.01.02 Any and all Federal, state and local taxes, charges, fees, or contributions required to be paid with respect to Contractor, Contractor's officers, employees and agents engaged in the performance of this Contract (including, without limitation, unemployment insurance, social security, and payroll tax withholding).

7 INSURANCE

7.01 General

Contractor, at its sole cost and expense, for the full term of this Contract (and any extensions thereof), shall obtain and maintain at minimum all of the following insurance coverage. Such insurance

coverage shall be primary coverage as respects District and any insurance or self-insurance maintained by District shall be excess of Contractor's insurance coverage and shall not contribute to it.

7.02 Types of Insurance and Minimum Limits

Contractor shall obtain and maintain during the term of this Contract:

- (1) Worker's Compensation and Employer's Liability Insurance in conformance with the laws of the State of California (not required for Contractor's subcontractors having no employees).
- (2) Contractor's vehicles used in the performance of this Contract, including owned, non-owned (e.g. owned by Contractor's employees), leased or hired vehicles, shall each be covered with Automobile Liability Insurance in the minimum amount of \$1,000,000.00 combined single limit per accident for bodily injury and property damage.
- (3) Contractor shall obtain and maintain Comprehensive General Liability Insurance coverage in the minimum amount of \$1,000,000.00 combined single limit, including bodily injury, personal injury, and property damage. Such insurance coverage shall include, without limitation:
 - (a) Contractual liability coverage adequate to meet the Contractor's indemnification obligations under this contract.
 - (b) Full Personal Injury coverage.
 - (c) Broad form Property Damage coverage.
 - (d) A cross-liability clause in favor of the District.

7.03 Other Insurance Provisions

- (1) As to all insurance coverage required herein, any deductible or self-insured retention exceeding \$5,000.00 shall be disclosed to and be subject to written approval by District.
- (2) If any insurance coverage required hereunder is provided on a "claims made" rather than "occurrence" form, Contractor shall maintain such insurance coverage for three (3) years after expiration of the term (and any extensions) of this Contract.
- (3) All required Automobile Liability Insurance and Comprehensive or Commercial General Liability Insurance shall contain the following endorsement as a part of each policy: "The Santa Cruz Metropolitan Transit District is hereby added as an additional insured as respects the operations of the named insured."
- (4) All the insurance required herein shall contain the following clause: "It is agreed that this insurance shall not be canceled until thirty (30) days after the District shall have been given written notice of such cancellation or reduction."
- (5) Contractor shall notify District in writing at least thirty (30) days in advance of any reduction in any insurance policy required under this Contract.
- (6) Contractor agrees to provide District at or before the effective date of this Contract with a certificate of insurance of the coverage required.

8. RESERVED

9. NO DISCRIMINATION

In connection with the performance of services provided under this Contract, Contractor or subcontractor shall not discriminate on the basis of race, color, creed, ancestry, national origin, religion, sex, sexual orientation, marital status, age, medical condition or disability discriminate or permit discrimination against any person or group of persons in any manner prohibited by Federal, State, or local laws.

10. DISADVANTAGED BUSINESS ENTERPRISES

The Board of Directors of the Santa Cruz Metropolitan Transit District has adopted a Disadvantaged Business Enterprise Policy to promote the participation of disadvantaged business enterprises (DBE's) in all areas of District contracting to the maximum extent practicable. Consistent with the DBE Policy, the Contractor shall take all necessary and reasonable steps to ensure that DBE firms have the maximum practicable opportunity to participate in the performance of this project and any subcontracting opportunities thereof.

11. PROMPT PAYMENT

The prime contractor agrees to pay each subcontractor under this prime contract for satisfactory performance of its contract no later than 30 days from the receipt of each payment the prime contractor receives from District. The prime contractor agrees further to return retainage payments to each subcontractor within 30 days after the subcontractor's work is satisfactorily completed. Any delay or postponement of payment from the above referenced time frame may occur only for good cause following written approval of the District. This applies to both DBE and non-DBE subcontractors.

Prime subcontractors must include the prompt payment language of paragraph 1 in all subcontracts, regardless of subcontractor's DBE status. Failure of a prime contractor to uphold prompt payment requirements for subcontractors will result in District withholding reimbursement for completed work.

12. RESERVED

13. MISCELLANEOUS PROVISIONS

13.01 Successors and Assigns

The Contract shall inure to the benefit of, and be binding upon, the respective successors and assigns, if any, of the parties hereto, except that nothing contained in this Article shall be construed to permit any attempted assignment which would be unauthorized or void pursuant to any other provision of this Contract.

13.02 Survival of Rights and Obligations

In the event of termination, the rights and obligations of the parties, which by their nature survive termination of the services covered by this Contract, shall remain in full force and effect after termination. Compensation and revenues due from one party to the other under this Contract shall be paid; loaned equipment and material shall be returned to their respective owners; the duty to maintain and allow inspection of books, accounts, records and data shall be extended as provided in Section 13.15; and the hold harmless agreement contained in Article 6 shall survive.

13.03 Limitation on District Liability

The District's liability is, in the aggregate, limited to the total amount payable under this Contract.

13.04 Drug and Alcohol Policy

Contractor shall comply with Federal Transit Administration's (FTA) drug and alcohol testing regulations, 49 CFR Parts 653 and 654. Contractor shall not use, possess, manufacture, or distribute

alcohol or illegal drugs during the performance of the Contract or while on District premises or distribute same to District employees.

13.05 Publicity

Contractor agrees to submit to District all advertising, sales promotion, and other public matter relating to any service furnished by Contractor wherein the District's name is mentioned or language used from which the connection of District's name therewith may, within reason, be inferred or implied. Contractor further agrees not to publish or use any such advertising, sales promotion or publicity matter without the prior written consent of District.

13.06 Consent to Breach Not Waiver

No provision hereof shall be deemed waived and no breach excused, unless such waiver or consent shall be in writing and signed by the party claimed to have waived or consented. Any consent by any party to, or waiver of, a breach by the other, whether express or implied, shall not constitute a consent to, waiver of, or excuse for any other different or subsequent breach.

13.07 No Conflict of Interest

Contractor represents that it currently has no interest, and shall not have any interest, direct or indirect, that would conflict in any manner with the performance of services required under this Contract

13.08 Prohibition of Discrimination against Qualified Handicapped Persons

Contractor shall comply with the provisions of Section 504 of the Rehabilitation Act of 1973, as amended, pertaining to the prohibition of discrimination against qualified handicapped persons in federally-assisted programs.

13.9 Cal OSHA/Hazardous Substances

13.9.01 Contractor shall comply with California Administrative Code Title 8, Section 5194, and shall directly (1) inform its employees of the hazardous substances they may be exposed to while performing their work on District property, (2) ensure that its employees take appropriate protective measures, and (3) provide the District's Manager of Facility Maintenance with a Material Safety Data Sheet (MSDS) for all hazardous substances to be used on District property.

13.9.02 Contractor shall comply with Cal OSHA regulations and the Hazardous Substance Training and Information Act. Further, said parties shall indemnify the District against any and all damage, loss, and injury resulting from non-compliance with this Article.

13.9.03 Contractor will comply with the Safe Drinking Water and Toxic Enforcement Act of 1986 (Proposition 65) California Health and Safety Code Section 25249.5 - 25249.13. Contractor will ensure that clear and reasonable warnings are made to persons exposed to those chemicals listed by the State of California as being known to cause cancer or reproductive toxicity.

13.9.04 Contractor shall be solely responsible for any hazardous material, substance or chemical released or threatened release caused or contributed to by Contractor. Contractor shall be solely responsible for all clean-up efforts and costs.

13.10 Non-Assignment of Contract

The Contractor shall not assign, transfer, convey, sublet, or otherwise dispose of the Contract or Contractor's right, title or interest in or to the same or any part thereof without previous written consent

by the District; and any such action by Contractor without District's previous written consent shall be void.

13.11 No Subcontract

Contractor shall not subcontract or permit anyone other than Contractor or its authorized staff and subcontractors to perform any of the scope of work, services or other performance required of Contractor under this Contract without the prior written consent of the District. Any such action by Contractor without District's previous consent shall be void.

13.12 Severability

If any provision of this Contract is held by a court of competent jurisdiction to be invalid, void or unenforceable, the remaining provisions shall continue in full force and effect, and shall in no way be affected, impaired or invalidated.

13.13 All Amendments in Writing

No amendment to this Contract shall be effective unless it is in writing and signed by duly authorized representatives of both parties.

13.14 Audit

This Contract is subject to audit by Federal, State, or District personnel or their representatives at no cost for a period of four (4) years after the date of expiration or termination of the Contract. Requests for audits shall be made in writing, and Contractor shall respond with all information requested within ten (10) calendar days of the date of the request. During the four-year period that the Contract is subject to audit, Contractor shall maintain detailed records substantiating all costs and expenses billed against the Contract.

13.15 Smoking Prohibited

Contractor, its employees and agents shall not smoke in any enclosed area on District premises or in a District vehicle.

13.16 Responsibility for Equipment

13.16.01 District shall not be responsible nor held liable for any damage to person or property consequent upon the use, or misuse, or failure of any equipment used by Contractor, or any of its employees, even though such equipment be furnished, rented or loaned to Contractor by District.

13.16.02 Contractor is responsible to return to the District in good condition any equipment, including keys, issued to it by the District pursuant to this Agreement. If the contractor fails or refuses to return District-issued equipment within five days of the conclusion of the contract work the District shall deduct the actual costs to repair or replace the equipment not returned from the final payment owed to contractor or take other appropriate legal action at the discretion of the District.

13.17 Grant Contracts

13.17.01 Contractor shall ensure throughout the terms of this Agreement that all federal, state and local laws and requirements are met including any requirements District is obligated to perform because of receipt of grant funding. Contractor shall also be required to fulfill its obligation as a federal and/or state and/or local sub-recipient of grant funding.

13.18 Time of the Essence

Time is of the essence in this Contract.

PART V

SPECIAL CONDITIONS OF THE CONTRACT

1. BASIC SCOPE OF WORK

1.01 Basic Scope of Work

Contractor shall, without limitation, furnish and deliver equipment in accordance with the "Specifications" section of the Invitation for Bids, dated October 24, 2008.

2. DEFINITIONS

2.01 General

The terms (or pronouns in place of them) have the following meaning in the Contract.

2.01.01 ACCEPTANCE DATE - The date on which delivery is deemed to be complete in accordance with the provisions of the Contract and accepted in writing by the District.

2.01.02 CONTRACT - The Contract consists of this document, the attachments incorporated herein in accordance with Article 2 of Part VI - "Contract for ITEM," and any written amendments made in accordance with Article 13.14 of Part IV - "General Conditions of the Contract".

2.01.03 CONTRACTOR - Synonymous with Bidder.

2.01.04 DAYS - Calendar Days

2.01.05 PROVISION - Any term, agreement, covenant, condition, clause, qualification, restriction, reservation, or other stipulation in the Contract that defines or otherwise controls, establishes, or limits the performance required or permitted by either party.

2.01.06 SCOPE OF WORK (OR "WORK") - The entire obligation under the Contract, including, without limitation, all labor, equipment, materials, supplies, transportation, services, and other work products and expenses, express or implied, in the Contract.

3. BUY AMERICA CERTIFICATE

Contractor shall comply with the requirements of Section 165(a) of the Surface Transportation Assistance Act of 1982 and the applicable regulations in 49 Code of Federal Register Part 661. As evidence of Contractor's knowledge and understanding and certification of intention of compliance, Contractor has executed a Buy America Certificate, which is included as part of the "Bid Form" and incorporated herein by reference. If steel and manufactured products are needed by Contractor for its performance under the provisions of the Contract, Contractor shall only use steel and manufactured products that were produced in the United States.

4. LIQUIDATED DAMAGES

If the work is not completed within the time required, damage will be sustained by the District. It is, and will be impracticable and extremely difficult to ascertain and determine the actual damage, which the District will sustain by reason of such delay; and it is therefore agreed that the Contractor shall pay to the District one hundred dollars (\$100.00) for each and every day's delay in finishing the Work beyond the time prescribed. If the Contractor fails to pay such liquidated damages, the District may deduct the amount thereof from any money due or that may become due the Contractor under the Contract.

The Work shall be regarded as completed upon the date the District has accepted the same in writing.

5 STATE CONTRACT PROVISIONS

- 5.01 In the performance of work under these provisions, Contractor and its subcontractors will not discriminate against any employee or applicant for employment because of race, religious creed, medical condition, color, marital status, ancestry, sex, age, national origin, or physical handicap (Government Code Section 12940 et seq.). Contractor and all its subcontractors will take affirmative action to ensure that applicants are employed, and that employees are treated during employment, without regard to their race, religious creed, medical condition, color, marital status, ancestry, sex, age, national origin, or physical handicap. such action shall include, but not be limited to, the following: employment, upgrading, demotion or transfer; recruitment or recruitment advertising; layoff or termination; rates of pay or other forms of compensation; and selection for training, including apprenticeship. Contractor and its subcontractors shall post in conspicuous places, available to employees and applicants for employment, notice to be provided by STATE setting for the provisions of this section.
- 5.02 Contractor and its subcontractors will permit access to all records of employment, employment advertisements, application forms, and other pertinent data and records by the State Fair Employment Practices and Housing Commission, or any other agency of the State of California designated by STATE, for the purpose of investigation to ascertain compliance with Section 1 of this Article
- 5.03 Contractor shall establish and maintain an accounting system and records that properly accumulate and segregate incurred costs by line item for the project. Contractor's accounting system shall conform to generally accepted accounting principles (GAAP), enable to determination of incurred costs at interim points of completion, and provide support for reimbursement payment vouchers or invoices. All accounting records and other supporting papers of Contractor connected with performance under this Agreement shall be maintained for a minimum of three years from the date of final payment to District under these provisions and shall be held open to inspection and audit by representatives of STATE and the Auditor General of the State and copies thereof will be furnished upon request.
- 5.04 Contractor agrees that contract cost principles at least as restrictive as 48 CFR, Federal Acquisition Regulation System, Chapter 1 Part 31, shall be used to determine the allow ability of individual items of costs. Contractor also agrees to comply with Federal procedures as set forth in 49 CFR, Part 18, Uniform Administrative Requirements for Grants-in-Aid to State and Local Governments.
- 5.05 For the purpose of determining compliance with Public Contract Code Section 10115, et seq., Military and Veterans Code Sections 999 et seq. and Title 2, California Code of Regulations, Section 1896.60 et seq., when applicable, and other matters connected with the performance of District's contracts with third parties pursuant to Government code Section 10532, Contractors and subcontractors shall maintain all books, documents, papers, accounting records, and other evidence pertaining to the performance of such contracts, including but not limited to, the costs of administering the various contracts. Contractor and its subcontractors shall make such materials available at their respective offices at all reasonable times during the contract period and for three years from the date of final payment under such contract. STATE, the State Auditor General, the Federal Highway Administration, or any duly authorized representative of the Federal Government shall have access to any books, records and documents that are pertinent to the Agreement for audits, examinations, excerpts, and transactions and copies thereof shall be furnished if requested.

6. LABOR HARMONY REQUIREMENT

The construction manager/general and sub-contractor(s) at all tiers must be able to furnish labor that can work in harmony with all other elements employed or to be employed in conjunction with the construction work on the site. Without limiting the generality of the foregoing, 'labor harmony' shall include a provision of labor that will not cause, cause to be threatened, engage in, or give rise to, either directly or indirectly, any work disruption, slowdowns

or stoppages, or any violence or harm to any persons or property while performing any work or activities affecting the project in any way, including but not limited to: (1) traveling to and from the work site; (2) loading, transporting and off-loading of equipment and materials on the construction site; (3) delivery, receipt and unloading of material or equipment, or the provision or receipt of any construction-related services at any designated storage area, or the work site; (4) the performing of the work of the contract at the work site; and on non-working time associated with the above while employees are on site (e.g. lunch hours, breaks, queuing for transportation, etc.).

If a contractor causes any work disruption, slowdowns or work stoppages as a result of its inability to ensure labor harmony, that contractor shall pay to District the sum of \$100 per day as liquated damages while such work disruption, slowdown or work stoppage is underway. As an independent and further remedy, District reserves the right to order the offending contractor to cease work on the project until such time as the work disruption, slowdown or stoppage is resolved and, if the work disruption, slowdown or stoppage is not resolved in District's opinion, within a reasonable period of time, District reserves the right to withdraw the contract from the contractor and to put such contract or remainder of such contract out for re-bid.

If District claims that this provision has been violated, the contractor(s) must agree to submit the issue to emergency arbitration for final and binding resolution. The permanent arbitrator over such disputes shall be the Honorable Nat Agliano, retired or, if he is unavailable, the Honorable Richard Silver, retired. If they decline to serve and the parties are unable to agree on an acceptable alternative, the arbitrator will be selected by petition to the Superior Court for the County of Santa Cruz. The Arbitrator's authority shall be limited to a determination of whether the Labor Harmony requirement has been violated and, if so, what shall be the remedy.

PART VI

CONTRACT FOR DEMOLITION SERVICES (09-01)

THIS CONTRACT is made effective on _____, 2005 between the SANTA CRUZ METROPOLITAN TRANSIT DISTRICT, a political subdivision of the State of California ("District"), and _____ ("Contractor").

1. RECITALS

1.01 District's Primary Objective

District is a public entity whose primary objective is providing public transportation and has its principal office at 370 Encinal Street, Suite 100, Santa Cruz, California 95060.

1.02 District's Need For Demolition Of Old Bus Wash Area

District requires demolition of Old Bus Wash Area. In order to obtain said demolition of Old Bus Wash Area, the District issued an Invitation for Bids, dated October 24, 2008 setting forth specifications for demolition of Old Bus Wash Area. The Invitation for Bids is attached hereto and incorporated herein by reference as Exhibit A.

1.03 Contractor's Bid Form

Contractor is a supplier of demolition services desired by the District and whose principal place of business is _____. Pursuant to the Invitation for Bids by the District, Contractor submitted a bid for Provision of said demolition of Old Bus Wash Area, which is attached hereto and incorporated herein by reference as Exhibit B.

1.04 Selection of Contractor and Intent of Contract

On January 28, 2005, District selected Contractor as the lowest responsive, responsible bidder to provide said equipment. The purpose of this Contract is to set forth the provisions of this procurement.

1.05 Contractor and Supplier Synonymous

For the purposes of this Contract, the terms "contractor" and "supplier" are synonymous.

District and Contractor agree as follows:

2. INCORPORATED DOCUMENTS AND APPLICABLE LAW

2.01 Documents Incorporated in This Contract

The documents below are attached to this Contract and by reference made a part hereof. This is an integrated Contract. This writing constitutes the final expression of the parties' Contract, and it is a complete and exclusive statement of the provisions of that Contract, except for written amendments, if any, made after the date of this Contract in accordance with Section 13.14 of the General Conditions of the Contract.

a) Exhibit A

Santa Cruz Metropolitan Transit District's "Invitation for Bids" dated October 24, 2008.

b) Exhibit B (Bid Form)

Contractor's Bid Form to the District for demolition of Old Bus Wash Area, signed by Contractor and dated December 5, 2008.

2.02 Conflicts

Where in conflict, the provisions of this writing supersede those of the above-referenced documents, Exhibits A and B. Where in conflict, the provisions of Exhibit A supersede Exhibit B.

2.03 Recitals

The Recitals set forth in Article 1 are part of this Contract.

3. TIME OF PERFORMANCE

3.01 General

Contractor shall perform work under this Contract at such times to enable it to meet the time schedules specified in the Specifications Section of the IFB. The Contractor shall not be responsible for delays caused by force majeure events described in Section 2 of the General Conditions of the Contract.

3.02 Term

The term of this Contract commences on the date of execution and shall remain in force for a one (1) year period thereafter. At the option of the District, this contract may be renewed for four (4) additional one (1) year terms under the same conditions and prices. District and Contractor may extend the term of this Contract at any time for any reason upon mutual written consent.

4. COMPENSATION

4.01 Terms of Payment

Upon written acceptance, District agrees to pay Contractor _____ as identified in the Bid Form, Exhibit B, not to exceed \$ _____, for satisfactory completion of all work under the terms and provisions of this Contract within forty-five (45) days thereof. Contractor understands and agrees that if he/she exceeds the \$ _____ maximum amount payable under this contract, that it does so at its own risk.

4.02 Invoices

Contractor shall submit invoices with a purchase order number provided by the District on a monthly basis. Contractor's invoices shall include detailed records showing actual time devoted, work accomplished, date work accomplished, personnel used, and amount billed per hour. Expenses shall only be billed if allowed under the contract. Telephone call expenses shall show the nature of the call and identify location and individual called.

Said invoice records shall be kept up-to-date at all times and shall be available for inspection by the District (or any grantor of the District, including, without limitation, any State or Federal agency providing project funding or reimbursement) at any time for any reason upon demand for not less than four (4) years after the date of expiration or termination of the contract. Under penalty of law, Contractor represents that all amounts billed to the District are (1) actually incurred; (2) reasonable in amount; (3) related to this contract; and (4) necessary for performance of the services. No expenses shall be paid by the District unless specifically allowed by this contract.

5. NOTICES

All notices under this Contract shall be deemed duly given upon delivery, if delivered by hand; or three (3) days after posting, if sent by registered mail, receipt requested; to a party hereto at the address hereinunder set forth or to such other address as a party may designate by notice pursuant hereto.

DISTRICT

Santa Cruz Metropolitan Transit District
370 Encinal Street
Suite 100
Santa Cruz, CA 95060

Attention: General Manager

CONTRACTOR

Attention: _____

6. AUTHORITY

Each party has full power and authority to enter into and perform this Contract and the person signing this Contract on behalf of each has been properly authorized and empowered to enter into it. Each party further acknowledges that it has read this Contract, understands it, and agrees to be bound by it.

Signed on _____

DISTRICT--SANTA CRUZ METROPOLITAN TRANSIT DISTRICT

Leslie R. White
General Manager

CONTRACTOR-- _____

By _____

Approved as to Form:

Margaret Rose Gallagher
District Counsel

PART VII

FEDERAL TRANSIT ADMINISTRATION REQUIREMENTS FOR CONSTRUCTION CONTRACTS

1.0 GENERAL

This contract is subject to the terms of a financial assistance contract between the Santa Cruz Metropolitan Transit District and the Federal Transit Administration (FTA) of the United States Department of Transportation.

2.0 INTEREST TO MEMBERS OF OR DELEGATES TO CONGRESS

In accordance with 18 U.S.C. 431, no member of, nor delegate to, the Congress of the United States shall be admitted to a share or part of this contract or to any benefit arising therefrom.

3.0 EQUAL EMPLOYMENT OPPORTUNITY

3.1 Nondiscrimination

- a. Instructions: All construction contracts in excess of \$10,000 by grantees and their contractors or sub grantees shall contain a provision requiring compliance with Executive Order 11246 entitled, "Equal Employment Opportunity", as amended by Executive Order 11375, and as supplemented in Department of Labor Regulations (41 CFR Part 60). The following clauses shall be included.
 - b. Mandatory Language: "During the performance of this contract, the contractor agrees as follows:
 - (1) The contractor or subcontractor will not discriminate against any employee or applicant for employment because of race, color, national origin or sex in the performance of this contract. The contractor shall carry out applicable requirements of 49CFR part 26 in the award and administration of DOT-assisted contracts. Failure by the contractor to carry out these requirements is a material breach of this contract, which may result in the termination of this contract or such other remedy as the District deems appropriate. The contractor will take affirmative action to ensure that applicants are employed, and that employees are treated during employment without regard to their race, color, religion, sex, age or national origin. Such action shall include, but not be limited to, the following: Employment, upgrading, demotion or transfer; recruitment or recruitment advertising; layoff or termination, rates of pay or other forms of compensation; and, selection of training including apprenticeship. The contractor agrees to post in conspicuous places, available to employees and applicants for employment, notices setting forth the provisions of this nondiscrimination clause.
 - (2) The contractor will, in all solicitations or advertisements for employees placed by or on behalf of the contractor, state that all qualified applicants will receive consideration for employment without regard to race, color, religion, sex, age or national origin.
 - (3) The contractor will send to each labor union or representative of workers with which he has a collective bargaining agreement or other contract or understanding, a notice advising the said labor union or workers' representatives of the contractor's commitments under this Section 202 of Executive Order 11246 of September 24, 1965, and shall post copies of the notice in conspicuous places available to employees and applicants for employment.

- (4) The contractor will comply with all provisions of Executive Order 11246 of September 24, 1965 as amended by Executive Order 11375 and with the rules, regulations and relevant orders of the Secretary of Labor.
- (5) The Contractor will furnish all information and reports required by Executive Order 11246 of September 24, 1965 and by rules, regulations and orders of the Secretary of Labor, or pursuant thereto, and will permit access to his books, records, and accounts by the Urban Mass Transportation Administration and the Secretary of Labor for purposes of investigation to ascertain compliance with such rules, regulations and orders.
- (6) In the event of the contractor's noncompliance with the nondiscrimination clauses of this agreement or with any of the said rules, regulations or orders, this agreement may be canceled, terminated or suspended in whole or in part. The contractor may be declared ineligible for further Government contracts or Federally assisted construction contracts or Federally assisted construction contracts in accordance with procedures authorized in Executive Order 11246 of September 24, 1965, as amended, and such other sanctions may be imposed and remedies invoked as provided in Executive Order 11246 of September 24, 1965, or by rule, regulation or order of the Secretary of Labor or as otherwise provided by law.
- (7) The contractor will include a citation to 42 CFR Part 60-1 (b) and (c) and the provisions of paragraphs (1) through (7) herein, in every subcontract or purchase order unless exempted by rules, regulations, or orders of the Secretary of Labor issued pursuant to Section 204 of Executive Order 11246 of September 24, 1965, as amended by Executive Order 11375. Such provisions shall be binding upon each subcontractor or vendor. The contractor will take such action with respect to any subcontract or purchase order as the Urban Mass Transportation Administration may direct as a means of enforcing such provisions, including sanctions for noncompliance; provided, however, that in the event a contractor becomes involved in, or is threatened with, litigation with a subcontractor or vendor as a result of such direction by the Urban Mass Transportation Administration, may direct as a means of enforcing such provisions, including sanctions for non-compliance, provided, however, that in the event a contractor becomes involved in, or is threatened with litigation with a subcontractor or vendor as a result of such litigation to protect the United States "
- (8) The prime contractor agrees to pay each subcontractor under this prime contract for satisfactory performance of its contract no later than 30 days from the receipt of each payment the prime contractor received from District. The prime contractor agrees to further return retainage payments to each subcontractor within 30 days after the subcontractor's work is satisfactorily completed. Any delay or postponement of payment from the above referenced time frame may occur only for good cause following written approval by the District. This applies to both DBE and non-DBE subcontractors. These records will be made available for inspection upon request of by any authorized representative if the District or DOT. This reporting requirement also extends to any certified DBE subcontractor.

3.2 Construction Contract Specifications

- a. Instructions for Use: The following clauses must also be included in all construction contracts and subcontracts over \$10,000 in geographical areas designated pursuant to 41 CFR Part 60-4.6.
 - b. Mandatory Language: Standard Federal Equal Employment Opportunity Construction Contract Specifications (Executive Order 11246).
- (1) As used in these Specifications
 - (a) "Covered area" means the geographical area described in the solicitation from which this contract resulted.

- (b) "Director" means Director, Office of Federal Contract Compliance Programs, United States Department of Labor, or any person to whom the Director delegates authority.
- (c) "Employer Identification Number" means the Federal Social Security number used on the employer's quarterly Federal Tax Return, U.S. Treasury Department Form 941.
- (d) "Minority" includes:
- 1) Hispanic (all persons of Mexican, Puerto Rican, Cuban, Central or South American or other Spanish culture or origin regardless of race);
 - 2) Black (all persons having origins in any of the Black African racial groups not of Hispanic origin);
 - 3) Asian and Pacific Islander (all persons having origins in any of the original people of the Far East, southeast Asia and the Indian subcontinent, or the Pacific Islands); and,
 - 4) American Indian or Alaskan native (all persons having origins in any of the original people of North America and maintaining identifiable tribal affiliations through membership and participation or community identification).
- (2) Whenever the contractor, or any subcontractor at any tier, subcontracts a portion of the work involving any construction trade, it shall physically include in each subcontract in excess of \$10,000 the provisions of these Specifications and the notice which contains the applicable goals for minority and female participation and which is set forth in the solicitation from which this contract resulted.
- (3) If the contractor is participating (pursuant to 41 CFR Part 60-4.5) in a hometown plan approved by the U. S. Department of Labor in the covered area, either individually or through an association, its affirmative action obligations on work in the plan area (including goals and time- tables) shall be in accordance with that plan for those trades which have unions participating in the plan. Contractors must be able to demonstrate their participation in and compliance with the provisions of any such hometown plan. Each contractor or subcontractor participating in an approved plan is individually required to comply with its obligations under the EEO clause, and to make a good faith effort to achieve each goal under the plan in each trade in which it has employees. The overall good faith performance by other contractors or subcontractors toward a goal in an approved plan does not excuse any covered contractor's failure to make good faith efforts to achieve the plan goals and timetables.
- (4) The contractor shall implement the specific affirmative action standards provided in (7) (a) through (p) of these Specifications. The goals set forth in the solicitation from which this contract resulted are expressed as percentages of the total hours of employment and training of minority and female utilization the contractor should reasonably be able to achieve in each construction trade in which it has employees in the covered area. Covered construction contractors performing construction work in geographical areas where they do not have a Federal or Federally assisted construction contract shall apply the minority and female goals established for the geographical area where the work is being performed. Goals are published periodically in the Federal Register in notice form, and such notices may be obtained from any Federal Contract Compliance Program Office or from Federal Procurement Contracting Officers. The contractor is expected to make substantially uniform progress toward its goals in each craft during the period specified.
- (5) Neither the provisions of any collective bargaining agreement, nor the failure by a union with whom the contractor has a collective bargaining agreement, to refer either minorities or women

shall excuse the Contractor's obligations under these Specifications, Executive Orders 11246 and 11375, or the Regulations promulgated pursuant thereto.

- (6) In order for the non-working training hours of apprentices and trainees to be counted in meeting the goals, such apprentices and trainees must be employed by the contractor during the training period, and the contractor must have made a commitment to employ the apprentices and trainees at the completion of their training, subject to the availability of employment opportunities. Trainees must be trained pursuant to training programs approved by the U. S. Department of Labor.
- (7) The contractor shall take specific affirmative actions to ensure equal employment opportunity. The evaluation of the Contractor's compliance with these Specifications shall be based upon its effort to achieve maximum results from its actions. The contractor shall document these efforts fully, and shall implement affirmative action steps at least as extensive as the following:
 - (a) Ensure and maintain a working environment free of harassment, intimidation and coercion at all sites, and in all facilities at which the contractor's employees are assigned to work. The contractor, where possible, will assign two or more women to each construction project. The contractor shall specifically ensure personnel are aware of and carry out the contractor's obligation to maintain such a working environment, with specific attention to minority or female individuals working at such sites or in such facilities.
 - (b) Establish and maintain a current list of minority and female recruitment sources, provide written notification to minority and female recruitment sources and to community organizations when the contractor or its unions have employment opportunities available, and maintain a record of the organizations' responses.
 - (c) Maintain a current file of the names, addresses and telephone numbers of each minority and female off-the-street applicant and minority or female referral service from a union, a recruitment source or community organization and of what action was taken with respect to each such individual. If such individual was sent to the union hiring hall for referral and was not referred back to the contractor by the union or if referred, not employed by the contractor, this shall be documented in the file with the reason therefore, along with whatever additional actions the contractor may have taken.
 - (d) Provide immediate written notification to the director when the union or unions with which the contractor has a collective bargaining agreement has not referred to the contractor a minority person or woman sent by the contractor, or when the contractor has other information that the union referral process has impeded the contractor's efforts to meet its obligations.
 - (e) Develop on-the-job training opportunities and/or participate in training programs for the area which expressly include minorities and women, including upgrading programs and apprenticeship and trainee programs relevant to the contractor's employment needs, especially those programs funded or approved by the Department of Labor. The contractor shall provide notice of these programs to the sources compiled under (7)(b) above.
 - (f) Disseminate the contractor's EEO policy by providing notice of the policy to unions and training programs and requesting their cooperation in assisting the contractor in meeting its EEO obligations; by including it in any policy manual and collective bargaining agreement; by publicizing it in the company newspaper, annual report, etc.; by specific review of the policy with all management personnel and with all minority and female employees at least once a year; and by posting the company EEO policy on bulletin

boards accessible to all employees at each location where construction work is performed.

- (g) Review, at least annually, the company's EEO policy and affirmative action obligations under these Specifications with all employees having responsibility for hiring, assignment, layoff, termination or other employment decisions including specific review of these items with on-site supervisory personnel such as superintendents, general foremen, etc., prior to the initiation of construction work at any job site. A written record shall be made and maintained identifying the time and place of these meetings, persons attending, subject matter discussed and disposition of the subject matter.
 - (h) Disseminate the contractor's EEO policy externally by including it in any advertising in the news media, specifically including minority and female news media, and providing written notification to and discussing the contractor's EEO policy with other contractors and subcontractors with whom the contractor does or anticipates doing business.
 - (i) Direct its recruitment efforts, both oral and written, to minority, female and community organizations, to schools with minority and female students and to minority and female recruitment and training organizations serving the contractor's recruitment area and employment needs. Not later than one month prior to the date for the acceptance of applications for apprenticeship or other training by any recruitment source, the contractor shall send written notification to organizations such as the above, describing the openings, screening procedures and tests to be used in the selection process.
 - (j) Encourage present minority and female employees to recruit other minority persons and women and, where reasonable, provide after school, summer and vacation employment to minority and female youth both on the site and in other areas of the contractor's work force.
 - (k) Validate all tests and other selection requirements where there is an obligation to do so under 41 CFR Part 60-3.
 - (l) Conduct at least annually, an inventory and evaluation at least of all minority and female personnel for promotional opportunities, and encourage these employees to seek or to prepare for, through appropriate training, etc., such opportunities.
 - (m) Ensure that seniority practices, job classifications, work assignments and other personnel practices, do not have a discriminatory effect by continually monitoring all personnel and employment-related activities to ensure that the EEO policy and the contractor's obligations under these Specifications are being carried out.
 - (n) Ensure that all facilities and company activities are non-segregated except that separate or single-user toilet and necessary changing facilities shall be provided to assure privacy between the sexes.
 - (o) Document and maintain a record of all solicitations of offers for subcontracts from minority and female construction contractors and suppliers, including circulation of solicitations to minority and female contractor associations and other business associations.
 - (p) Conduct a review, at least annually, of all supervisors' adherence to and performance under the contractor's EEO policies and affirmative action obligations.
- (8) Contractors are encouraged to participate in voluntary associations which assist in fulfilling one or more of their affirmative action obligations set forth in paragraphs (7) (a) through (p). The efforts of a contractor association, joint contractor-union, contractor community, or other

similar group of which the contractor is a member and participant, may be asserted as fulfilling any one or more of its obligations under (7)(a) through (p) of these Specifications, provided that the contractor actively participates in the group, makes every effort to assure that the group has a positive impact on the employment of minorities and women in the industry, ensures that the concrete benefits of the program are reflected in the contractor's minority and female work force and participation makes a good faith effort to meet its individual goals and timetables, and can provide access to documentation which demonstrates the effectiveness of actions taken on behalf of the contractor. The obligation to comply, however, is the contractor's and failure of such a group to fulfill an obligation shall not be a defense for the contractor's noncompliance.

- (9) A single goal for minorities and separate single goal for women have been established. The contractor, however, is required to provide equal employment opportunity and to take affirmative action for all minority groups, both male and female, and all women, both minority and non-minority. Consequently, the contractor may be in violation of the Executive Order if a particular group is employed in a substantially disparate manner (for example, even though the contractor has achieved its goal for women generally, the contractor may be in violation of the Executive Order if a specific minority group of women is underutilized).
- (10) The contractor shall not use the goals and timetables of affirmative action to discriminate against any person because of race, color, religion, sex, age or national origin.
- (11) The contractor shall not enter into any subcontract with any person or firm debarred from government contracts pursuant to Executive Order 11246, as amended by Executive Order 11375.
- (12) The contractor shall carry out such sanctions and penalties for violation of these Specifications and of the equal opportunity clause, including suspension, termination and cancellation of existing subcontracts as may be imposed or ordered pursuant to Executive Order 11246, as amended, and its implementing regulations by the Office of Federal Contract Compliance Programs. Any contractor who fails to carry out such sanctions and penalties shall be in violation of these Specifications and Executive Order 11246, as amended.
- (13) The contractor, in fulfilling its obligations under these Specifications, shall implement specific affirmative action steps, at least as extensive as those standards prescribed in paragraph (7) of these Specifications, so as to achieve maximum results from its efforts to ensure equal employment opportunity. If the contractor fails to comply with the requirements of the Executive Order, the implementing regulation, or these Specifications, the Director shall proceed in accordance with 41 CFR Part 60-4.8.
- (14) The contractor shall designate a responsible official to monitor all employment related activity to ensure that the company EEO policy is being carried out, to submit reports relating to the provisions herein as may be required by the Government and to keep records. Records shall at least include for each employee the name, address, telephone numbers, construction trade, union affiliation if any, employee identification number when assigned, Social Security number, race, sex, status (e.g., mechanic, apprentice, trainee, helper or laborer), dates of changes in status, hours worked per week in the indicated trade, rate of pay and locations at which the work was performed. Records shall be maintained in an easily understandable and retrievable form; however, to the degree that existing record satisfy this requirement, contractors shall not be required to maintain separate records.
- (15) Nothing herein shall be construed as a limitation upon the application of other laws which establish different standards of compliance or upon the application of requirements for the hiring of local or other area residents (e.g., those under the Public Works Employment Act of 1977 and the Community Development Block Grant Program)." 3.3 Construction Contract Notice

- a. Instructions for Use: The following notice must be included in all construction subcontracts over \$10,000 in geographical areas designated pursuant to 41 CFR Part 60-4.2.
 - b. Mandatory Language: "Notice of Requirement For Affirmative Action to Ensure Equal Employment Opportunity (Executive Order 11246):
- (1) The bidder's attention is called to the 'Equal Opportunity Clause' and the 'Standard Federal Equal Employment Opportunity Construction Contract Specifications' set forth herein.
- (a) The goals and timetables for minority and female participation, expressed in percentage terms for the contractor's aggregate work force in each trade on all construction work in the covered area, are as follows:

These goals are applicable to all the contractor's construction work (whether or not it is Federal or Federally assisted) performed in the covered area. If the contractor performs construction work in a geographical area located outside the covered area, it shall apply the goals established for such geographical area where the work is actually performed. With regard to this second area, the contractor also is subject to the goals for both its Federally involved and non-Federally involved construction.

- (b) The contractor's compliance with the Executive Order and the regulations in 41 CFR Part 60-4 shall be based on its implementation of the Equal Opportunity clause, specific affirmative action obligations required by the Specifications set forth in 41 CFR Part 60-4 3(a), and its efforts to meet the goals. The hours of minority and female employment and training must be substantially uniform throughout the length of the contract, and in each trade, and the contractor shall make a good faith effort to employ minorities and women evenly on each of its projects. The transfer of minority or female employees or trainees from contractor to contractor or from project to project for the sole purpose of meeting the contractor's goals shall be a violation of the contract, the Executive Order, and the regulations in 41 CFR Part 60-4. Compliance with the goals will be measured against the total work hours performed.
- (3) The contractor shall provide written notification to the Director of the Office of Federal Contract Compliance programs within 10 working days of award of any construction subcontract in excess of \$10,000 at any tier for construction work under the contract resulting from this solicitation. The notification shall list the name, address and telephone number of the subcontractor; employer identification number of the subcontractor; estimated dollar amount of the subcontract; and, the geographical area in which the contract is to be performed.

4.0 TITLE VI CIVIL RIGHTS ACT OF 1964

During the performance of this Contract, the Contractor, for itself, its assignees and successors in interest (hereinafter referred to as the "Contractor"), agrees as follows:

4.1 Compliance with Regulations

The Contractor shall comply with the Regulations relative to nondiscrimination in federally assisted programs of the Department of Transportation (hereinafter "DOT") Title 49, Code of Federal Regulations, Part 21, as they may be amended from time to time (hereinafter referred to as the "Regulations"), which are herein incorporated by reference and made a part of this Contract.

4.2 Nondiscrimination

The Contractor, with regard to the work performed by it during the Contract, shall not

discriminate on the grounds of race, religion, color, sex, age or national origin in the selection and retention of subcontractors, including procurements of materials and leases of equipment. The Contractor shall not participate either directly or indirectly in the discrimination prohibited in Section 21.5 of the Regulations, including employment practices when the Contract covers a program set forth in Appendix B of the regulations

4.3 Solicitations for Subcontracts, Including Procurements of Materials and Equipment

In all solicitations either by competitive bidding or negotiation made by the Contractor for work to be performed under a subcontract, including procurements of materials or leases of equipment, each potential subcontractor or supplier shall be notified by the Contractor of the Contractor's obligations under this Contract and the Regulations relative to nondiscrimination on the grounds of race, religion, color, sex, age or national origin.

4.4 Information and Reports

The Contractor shall provide all information and reports required by the Regulations or directives issued pursuant thereto, and shall permit access to its books, records, accounts, other sources of information, and its facilities as may be determined by the District or the Federal Transit Administration (FTA) to be pertinent to ascertain compliance with such Regulations, orders and instructions. Where any information is required or a Contractor is in the exclusive possession of another who fails or refuses to furnish this information, the Contractor shall so certify to the District, or the Federal Transit Administration, as appropriate, and shall set forth what efforts it has made to obtain the information.

4.5 Sanctions for Noncompliance

In the event of the Contractor's noncompliance with the nondiscrimination provisions of this Contract, the District shall impose such contract sanctions as it or the Federal Transit Administration may determine to be appropriate, including, but not limited to:

- (a) Withholding of payments to the Contractor under the Contract until the Contractor complies; and/or,
- (b) Cancellation, termination or suspension of the Contract, in whole or in part.

4.6 Incorporation of Provisions

The Contractor shall include the provisions of Paragraphs (1) through (6) of this section in every subcontract, including procurements of materials and leases of equipment, unless exempt by the Regulations or directives issued pursuant thereto. The Contractor shall take such action with respect to any subcontract or procurement as the District or the Federal Transit Administration may direct as a means of enforcing such provisions, including sanctions for noncompliance; provided, however, that in the event a Contractor becomes involved in, or is threatened with, litigation with a subcontractor or supplier as a result of such direction, the Contractor may require the District to enter into such litigation to protect the interests of the District, and, in addition, the Contractor may request the services of the Attorney General in such litigation to protect the interests of the United States.

5.0 CLEAN AIR AND FEDERAL WATER POLLUTION CONTROL ACTS (Applicable only to contracts in excess of \$100,000)

Contractor shall comply with all applicable standards, orders or requirements issued under Section 306 of the Clean Air Act (42 USC 1857[h]), Section 508 of the Clean Water Act (33 USC 1368), Executive Order 11738, and Environmental Protection Agency Regulations (40 CFR, Part 15), which prohibit the use under non-exempt Federal

contracts, grants or loans of facilities included on the EPA List of Violating Facilities. Contractor shall report all violations to FTA and to the USEPA Assistant Administrator for Enforcement (EN0329).

6.0 CONSERVATION

Contractor shall recognize mandatory standards and policies relating to energy efficiency, which are contained in the State energy conservation plan issued in compliance with the Energy Policy and Conservation Act (42 USC Section 6321, et seq).

7.0 AUDIT AND INSPECTION OF RECORDS (Applicable only to sole source or negotiated contracts in excess of \$10,000)

Contractor agrees that the District, the Comptroller General of the United States, or any of their duly authorized representatives shall, for the purpose of audit and examination, be permitted to inspect all work, materials, payrolls and other data and records with regard to the project, and to audit the books, records and accounts with regard to the project. Further, Contractor agrees to maintain all required records for at least three years after District makes final payments and all other pending matters are closed.

8.0 LABOR PROVISIONS

Pursuant to regulations set forth at 29 CFR Part 5, the following provisions shall be incorporated in all construction contracts of \$2,000 or more let by the recipient in carrying out the project.

8.1 Minimum Wages

- a. All laborers and mechanics employed or working upon the site of the work (or under the United States Housing Act of 1937 or under the Housing Act of 1949 in the construction or development of the project), will be paid unconditionally and not less often than once a week, and without subsequent deduction or rebate on any account (except such payroll deductions are as permitted by regulations issued by the Secretary of Labor under the Copeland Act [29 CFR Part 3]), the full amount of wages and bona fide fringe benefits (or cash equivalents thereof) due at time of payment computed at rates not less than those contained in the wage determination of the Secretary of Labor which is attached hereto and made a part hereof, regardless of any contractual relationship which may be alleged to exist between the contractor and such laborers and mechanics. Contributions made or costs reasonably anticipated for bona fide fringe benefits under Section 1(b)(2) of the Davis-Bacon Act on behalf of laborers or mechanics are considered wages paid to such laborers or mechanics, subject to the provisions of paragraph (a)(1)(iv) of 29 CFR 5.5; also, regular contributions made or costs incurred for more than a weekly period (but not less often than quarterly) under plans, funds or programs which cover the particular weekly period, are deemed to be constructively made or incurred during such weekly period. Such laborers and mechanics shall be paid the appropriate wage rate and fringe benefits on the wage determination for the classification of work actually performed, without regard to skill, except as provided in 29 CFR 5.5(a)(4). Laborers or mechanics performing work in more than one classification may be compensated at the rate specified for each classification for the time actually worked therein; provided, that the employer's payroll record accurately sets forth the time spent in each classification in which work is performed. The wage determination (including any additional classification and wage rates conformed under paragraph (a)(1)(ii) of 29 CFR 5.5 and the Davis-Bacon poster (WH-1321) shall be posted at all times by the contractor and its subcontractors at the site of the work in a prominent and accessible place where it can be easily seen by the workers.
- (1) The contracting officer shall require that any class of laborers or mechanics which is not listed in the wage determination and which is to be employed under the contract shall be classified in conformance with the wage determination. The contracting officer shall approve an additional classification and wage rate and fringe benefits therefore only when the following criteria have been met:

- (a) The work performed by the classification requested is not performed by a classification in the wage determination; and
 - (b) The classification is utilized in the area by the construction industry; and
 - (c) The proposed wage rate, including any bona fide fringe benefits, bears a reasonable relationship to the wage rates contained in the wage determination.
- (2) If the contractor and the laborers and mechanics to be employed in the classification (if known), or their representatives, and the contracting officer agree on the classification and wage rate (including the amount designated for fringe benefits where appropriate), a report of the action taken shall be sent by the contracting officer to the Administration, U.S. Department of Labor, Washington DC 20210. The Administrator, or an authorized representative, will approve, modify or disapprove every additional classification action within 30 days of receipt and so advise the contracting officer or will notify the contracting officer within the 30-day period that additional time is necessary.
- (3) In the event the contractor, the laborers or mechanics to be employed in the classification or their representatives, and the contracting officer do not agree on the proposed classification and wage rate (including the amount designated for fringe benefits, where appropriate), the contracting officer shall refer the questions including the views of all interested parties and the recommendation of the contracting officer to the Administrator for determination. The Administrator, or an authorized representative, will issue a determination within 30 days of receipt and so advise the contracting officer or will notify the contracting officer within the 30-day period that additional time is necessary.
- (4) The wage rate (including fringe benefits where appropriate) determined pursuant to subparagraphs (a)(1)(B) or (C) of 29 CFR 5.5, shall be paid to all workers performing work in the classification under this contract from the first day on which work is performed in the classification.
- b. Whenever the minimum wage rate prescribed in the contract for a class of laborers or mechanics includes a fringe benefit which is not expressed as an hourly rate, the contractor shall either pay the benefit as stated in the wage determination or shall pay another bonafide fringe benefit or an hourly cash equivalent thereof.
 - c. If the contractor does not make payments to a trustee or other third person, the contractor may consider as part of the wages of any laborer or mechanic the amount of any costs reasonably anticipated in providing bona fide fringe benefits under a plan or program, provided that the Secretary of Labor has found, upon the written request of the contractor, that the applicable standards of the Davis-Bacon Act have been met. The Secretary of Labor may require the contractor to set aside in a separate account assets for the meeting of obligations under the plan or program.

8.2 Withholding

- a. DOI shall, upon its own action or upon written request of an authorized representative of the Department of Labor, withhold or cause to be withheld from the contractor under this contract or any other Federal contract with the same prime contractor, or any other Federally-assisted contract subject to Davis-Bacon prevailing wage requirements, which is held by the same prime contractor, so much of the accrued payments or advances as may be considered necessary to pay laborers and mechanics, including apprentices, trainees and helpers, employed by the contractor or any subcontractor the full amount of wages required by the contract. In the event of failure to pay any laborer or mechanic, including any apprentice, trainee or helper, employed or working on the site of the work (or under the United States

Housing Act of 1937 or under the Housing Act of 1949 in the construction or development of the project), all or part of the wages required by the contract, DOI may, after written notice to the contractor, sponsor, applicant or owner, take such action as may be necessary to cause the suspension of any further payment, advance or guarantee of funds until such violations have ceased

8.3 Payrolls and Basic Records

- a. Payrolls and basic records relating thereto shall be maintained by the contractor during the course of the work and preserved for a period of three years thereafter for all laborers and mechanics working at the site of the work (or under the United States Housing Act of 1937, or under the Housing Act of 1949, in the construction or development of the project). Such records shall contain the name, address and Social Security number of each such worker, his or her correct classification, hourly rates of wages paid (including rates of contributions or costs anticipated for bona fide fringe benefits or cash equivalents thereof of the types described in Section 1(b) (2)(B) of the Davis-Bacon Act, daily and weekly number of hours worked, deductions made and actual wages paid. Whenever the Secretary of Labor has found under 29 CFR 5.5 (a)(1)(iv) that the wages of any laborer or mechanic include the amount of any costs reasonably anticipated in providing benefits under a plan or program described in Section 1 (b)(2)(B) of the Davis-Bacon Act, the contractor shall maintain records which show that the commitment to provide such benefits is enforceable, that the plan or program is financially responsible, and that the plan or program has been communicated in writing to the laborers or mechanics affected, and records which show the costs anticipated or the actual costs incurred in providing such benefits. Contractors employing apprentices or trainees under approved programs shall maintain written evidence of the registration of apprenticeship programs and certification of trainee programs, the registration of the apprentices and trainees, and the ratios and wage rates prescribed in the applicable programs.
 - (1) The contractor shall submit weekly for each week in which any contract work is performed, a copy of all payrolls to the grantee. The payrolls submitted shall set out accurately and completely all of the information required to be maintained under 5.5 (a)(3) of Regulations, 29 CFR Part 5. This information may be submitted in any form desired. Optional form WH-347 is available for this purpose and may be purchased from the Superintendent of Documents (Federal stock number 029-005-00014-1) U.S. Government Printing Office, Washington DC 20402. The prime contractor is responsible for the submission of copies of payrolls by all subcontractors.
 - (2) Each payroll submitted shall be accompanied by a "Statement of Compliance", signed by the contractor or subcontractor or his or her agent who pays or supervises the payment of the persons employed under the contract and shall certify the following:
 - (a) That the payroll for the payroll period contains the information required to be maintained under Section 5.5(a)(3)(i) of Regulations, 29 CFR Part 5 and that such information is correct and complete.
 - (b) That each laborer or mechanic (including each helper, apprentice and trainee) employed on the contract during the payroll period has been paid the full weekly wages earned, without rebate, either directly or indirectly, and that no deductions have been made either directly or indirectly from the full wages earned, other than permissible deductions as set forth in regulations 29 CFR Part 3.
 - (c) That each laborer or mechanic has been paid not less than the applicable wage rates and fringe benefits or cash equivalents for the classification of work performed, as specified in the applicable wage determination incorporated into the contract.

- (3) The weekly submission of a properly executed certification set forth on the reverse side of optional Form WH-347 shall satisfy the requirement for submission of the "Statement of Compliance" required by paragraph (a)(3)(ii)(B) of 29 CFR Section 5.5.
 - (4) The falsification of any of the above certifications may subject the contractor or subcontractor to civil or criminal prosecution under Section 1001 of Title 18 and Section 231 of Title 31 of the United States Code.
- b. The contractor or subcontractor shall make the records required under paragraph (a)(3)(i) of 29 CFR Section 5.5 available for inspection, copying or transcription by authorized representatives of DOT or the Department of Labor, and shall permit such representatives to interview employees during working hours on the job. If the contractor or subcontractor fails to submit the required records or to make them available, the Federal agency may, after written notice to the contractor, sponsor, applicant, or owner, take such action as may be necessary to cause the suspension of any further payment, advance or guarantee of funds. Furthermore, failure to submit the required records upon request or to make such records available may be grounds for debarment action pursuant to 29 CFR Section 5.12.

8.4 Apprentices and Trainees -- Apprentices

- a. Apprentices will be permitted to work at less than the predetermined rate for the work they performed when they are employed pursuant to and individually registered in a bona fide apprenticeship program registered with the U.S. Department of Labor, Employment and Training Administration, Bureau of Apprenticeship and Training, or with a state apprenticeship agency recognized by the Bureau, or if a person is employed in his or her first 90 days of probationary employment as an apprentice in such an apprenticeship program, who is not individually registered in the program, but who has been certified by the Bureau of Apprenticeship and Training or a state apprenticeship agency (where appropriate) to be eligible for probationary employment as an apprentice. The allowable ratio of apprentices to journeymen on the job site in any craft classification shall not be greater than the ratio permitted to the contractor as to the entire work force under the registered program. Any worker listed on a payroll at an apprentice wage rate, who is not registered or otherwise employed as stated above, shall be paid not less than the applicable wage rate on the wage determination for the classification of work actually performed. In addition, any apprentice performing work on the job site in excess of the ratio permitted under the registered program shall be paid not less than the applicable wage rate on the wage determination for the work actually performed. Where a contractor is performing construction on a project in a locality other than that in which its program is registered, the ratios and wage rates (expressed in percentages of the journeyman hourly rate) specified in the contractor's or subcontractor's registered program shall be observed. Every apprentice must be paid at not less than the rates specified in the registered program for the apprentice's level of progress, expressed as a percentage of the journeyman's hourly rate specified in the applicable wage determination. Apprentices shall be paid fringe benefits in accordance with the provisions of the apprenticeship program. If the apprenticeship program does not specify fringe benefits, apprentices must be paid the full amount of fringe benefits listed on the wage determination for the applicable classification. If the Administrator determines that a different practice prevails for the applicable apprentice classification, fringe benefits shall be paid in accordance with that determination. In the event the Bureau of Apprenticeship and Training, or a state apprenticeship agency recognized by the Bureau, withdraws approval of an apprenticeship program, the contractor will no longer be permitted to utilize apprentices at less than the applicable predetermined rate for the work performed until an acceptable program is approved.
- b. Trainees. Except as provided in 29 CFR Section 5.16, trainees will not be permitted to work at less than the predetermined rate for the work performed unless they are employed pursuant to and individually registered in a program which has received prior approval, evidenced by formal certification by the U.S. Department of Labor, Employment and Training

Administration. The ratio of trainees to journeymen on the site shall not be greater than permitted under the plan approved by the Employment and Training Administration. Every trainee must be paid at not less than the rate specified in the approved program for the trainee's level of progress, expressed as a percentage of the journeyman's hourly rate specified in the applicable wage determination. Trainees shall be paid fringe benefits in accordance with the provisions of the trainee program if the trainee program does not mention fringe benefits, trainees shall be paid the full amount of fringe benefits listed on the wage determination unless the Administrator of the Wage and Hour Division determines that there is an apprenticeship program associated with the corresponding journeyman's wage rate on the wage determination for the classification of work actually performed. In addition, any trainee performing work on the job site in excess of the ratio permitted under the registered program shall be paid not less than the applicable wage rate on the wage determination for the work actually performed. In the event the Employment and Training Administration withdraws approval of a training program, the contractor will no longer be permitted to utilize apprentices at less than the applicable predetermined rate for the work performed until an acceptable program is approved.

- c. Equal Employment Opportunity. The utilization of apprentices, trainees and journeymen under this part shall be in conformity with the equal employment opportunity requirements of Executive Order 11246, as amended, and 29 CFR Part 30.

8.5 Compliance with Copeland Act Requirements

The contractor shall comply with the requirements of 18 U.S.C. 874 and 29 CFR Part 3, which are incorporated by reference. This act provides that each contractor or sub grantee shall be prohibited from inducing, by any means any person employed in the construction, completion or repair of public work, to give up any part of the compensation to which he is otherwise entitled.

8.6 Contract Termination - Debarment

A breach of the contract clauses in 29 CFR Section 5.5 may be grounds for termination of the contract, and for debarment as a contractor and a subcontractor as provided in 29 CFR Section 5.12.

8.7 Compliance with Davis-Bacon and Related Act Requirements

All rulings and interpretations of the Davis-Bacon and related acts contained in 29 CFR Parts 1,3 and 5 are herein incorporated by reference.

8.8 Disputes Concerning Labor Standards

Disputes arising out of the general disputes clause of this contract shall not be subject to the general disputes clause of this contract. Such disputes shall be resolved in accordance with the procedures of the Department of Labor set forth in 29 CFR Parts 5, 6 and 7. Disputes within the meaning of this clause include disputes between the contractor (or any of its subcontractors) and the contracting agency, the U.S. Department of Labor, or the employees of their representatives.

8.9 Certification of Eligibility

- a. By entering into this contract the contractor certifies that neither it (nor he or she) nor any person or firm who has an interest in the contractor's firm is a person or firm ineligible to be awarded government contracts by virtue of Section 3(a) of the Davis-Bacon Act or 29 CFR Section 5.12 (a)(1).

- b. No part of this contract shall be subcontracted to any person or firm ineligible for award of a government contract by virtue of Section 3 (a) of the Davis-Bacon Act or 29 CFR Section 5.12 (a) (1).
- c. The penalty for making false statements is prescribed in the U.S. Criminal Code, 18 U.S.C. Section 1001.

8.10 Overtime Requirements

No contractor or subcontractor contracting for any part of the contract work which may require or involve the employment of laborers or mechanics shall require or permit any such laborer or mechanic in any work week in which he or she is employed on such work to work in excess of eight (8) hours in any calendar day or in excess of forty (40) hours in such work week unless such laborer or mechanic receives compensation at a rate not less than one-and-one-half (1-1/2) times the basic rate of pay for all hours worked in excess of eight (8) hours in any calendar day or in excess of forty (40) hours in such work week, whichever is greater.

8.11 Violation; Liability for Unpaid Wages; Liquidated Damages

In the event of any violation of the clause set forth in subparagraph (b)(1) of 29 CFR Section 5.5, the contractor and any subcontractor responsible therefore shall be liable for the unpaid wages. In addition, such contractor and subcontractor shall be liable to the United States (in the case of work done under contract for the District of Columbia or a territory, to such district or to such territory), for liquidated damages. Such liquidated damages shall be computed with respect to each individual laborer or mechanic, including watchmen and guards, employed in violation of the clause set forth in subparagraph (b)(1) of 29 CFR Section 5.5 in the sum of \$10 for each calendar day on which such individual was required or permitted to work in excess of eight (8) hours or in excess of the overtime wages required by the clause set forth in subparagraph (b)(1) of 29 CFR Sec. 5.5.

8.12 Withholding for Unpaid Wages and Liquidated Damages

DOI or the recipient shall, upon its own action or upon written request of an authorized representative of the Department of Labor, withhold or cause to be withheld, from any monies payable on account of work performed by the contractor or subcontractor under any such contract or any other Federal contract with the same prime contractor, or any other Federally assisted contract which is held by the same prime contractor, such sums as may be determined to be necessary to satisfy any liabilities of such contractor or subcontractor for unpaid wages and liquidated damages as provided in the clause set forth in subparagraph (b)(2) of 29 CFR Section 5.5.

- 8.13 Section 107 of C.W.H.S.S.A is applicable to construction work and provides that no laborer or mechanic shall be requested to work in surroundings or under working conditions, which are unsanitary, hazardous, or dangerous to his health and safety as determined under construction, safety and health standards promulgated by the Secretary of Labor. These requirements do not apply to the purchases of supplies or materials or articles ordinarily available on the open market or contracts for transportation or transmission of intelligence.

8.14 Non-Construction Grants

The contractor or subcontractor shall maintain payrolls and basic payroll records during the course of the work and shall preserve them for a period of three years from the completion of the contract for all laborers and mechanics, including guards and watchmen, working on the contract. Such records shall contain the name and address of each such employee, Social Security number, correct classifications, hourly rates of wages paid, daily and weekly number

of hours worked, deductions made, and actual wages paid. Further, the recipient shall require the contracting officer to insert in any such contract a clause providing that the records to be maintained under this paragraph shall be made available by the contractor or subcontractor for inspection, copying or transcription by authorized representatives of DOI and the Department of Labor, and the contractor or subcontractor will permit such representatives to interview employees during working hours on the job.

8.15 Subcontracts

The contractor or subcontractor shall insert in any subcontracts the clauses set forth in paragraphs 9.1 through 9.15 of this document and also a clause requiring the subcontractors to include these clauses in any lower tier subcontracts. The prime contractor shall be responsible for compliance by any subcontractor or lower tier subcontractor with the clauses set forth in paragraphs 9.1 through 9.15 of this document.

9.0 CARGO PREFERENCE (Applicable only to Contracts under which equipment, materials or commodities may be transported by ocean vehicle in carrying out the project)

The Contractor agrees:

9.1 To utilize privately owned United States-flag commercial vessels to ship at least fifty percent (50%) of the gross tonnage (computed separately for dry bulk carriers, dry cargo liners and tankers) involved, whenever shipping any equipment, materials or commodities pursuant to this section, to the extent such vessels are available at fair and reasonable rates for United States-flag commercial vessels.

9.2 To furnish within 30 days following the date of loading for shipments originating within the United States, or within thirty (30) working days following the date of loading for shipment originating outside the United States, a legible copy of a rated, "on-board" commercial ocean bill-of-lading in English for each shipment of cargo described in paragraph (1) above, to the District (through the prime Contractor in the case of subcontractor bills-of-lading) and to the Division of National Cargo, Office of Market Development, Maritime Administration, 400 Seventh Street, S.W., Washington D. C. 20590, marked with appropriate identification of the project

9.3 To insert the substance of the provisions of this clause in all subcontracts issued pursuant to this Contract.

10.0 BUY AMERICA PROVISION

This procurement is subject to the Federal Transportation Administration Buy America Requirements in 49 CFR 661.

A Buy America Certificate, if required format (see Form of Proposal or Bid Form) must be completed and submitted with the bid. A bid which does not include the certificate shall be considered non-responsive.

A waiver from the Buy America Provision may be sought by the District if grounds for the waiver exist.

Section 165a of the Surface Transportation Act of 1982 permits FTA participation on this Contract only if steel and manufactured products used in the Contract are produced in the United States.

In order for rolling stock to qualify as a domestic end product, the cost of components produced in the United States must exceed sixty percent (60%) of the cost of all components, and final assembly must take place in the United States.

11.0 DISADVANTAGED BUSINESS ENTERPRISE (DBE) PARTICIPATION

11.1 Policy

It is the policy of the U.S. Department of Transportation that Disadvantaged Business Enterprises as defined in 49 CFR Part 23 shall have the maximum opportunity to participate in the performance of contracts financed in whole or in part with Federal funds under this Agreement. Consequently, the DBE requirements of 49 CFR Part 23 apply to this Agreement.

11.2 DBE Obligation

District and Contractor agree to insure that Disadvantaged Business Enterprises as defined in 49 CFR Part 23 have the maximum opportunity to participate in the performance of contracts and subcontracts under this Agreement. In this regard, District and Contractor shall take all necessary and reasonable steps in accordance with 49 CFR Part 23 to insure that Disadvantaged Business Enterprises have the maximum opportunity to compete for and perform Contracts. District and Contractor shall not discriminate on the basis of race, creed, color, national origin, age or sex in the award and performance of DOI-assisted Contracts.

12.0 CONFLICT OF INTEREST

No employee, officer or agent of the District shall participate in selection, or in the award or administration of a contract if a conflict of interest, real or apparent, would be involved. Such a conflict would arise when (1) the employee, officer or agent; (2) any member of his or her immediate family; (3) his or her partner; or (4) an organization that employs, or is about to employ, has a financial or other interest in the firm selected for award. The District's officers, employees or agents shall neither solicit nor accept gratuities, favors or anything of monetary value from Contractors, potential Contractors or parties of sub agreements.

13.0 DEBARRED BIDDERS

The Contractor, including any of its officers or holders of a controlling interest, is obligated to inform the District whether or not it is or has been on any debarred bidders' list maintained by the United States Government. Should the Contractor be included on such a list during the performance of this project, Contractor shall so inform the District.

14.0 PRIVACY (Applicable only to Contracts involving the administration of any system of records as defined by the Privacy Act of 1974, on behalf of the Federal Government)

14.1 General

The District and Contractor agree:

- (a) To comply with the Privacy Act of 1974, 5 U.S.C. 552a (the Act) and the rules and regulations issued pursuant to the Act when performance under the Contract involves the design, development or operation of any system of records on individuals to be operated by the District, its contractors or employees to accomplish a Government function.
- (b) To notify the Government when the District or Contractor anticipates operating a system of records on behalf of the Government in order to accomplish the requirements of this Agreement, if such system contains information about individuals which information will be retrieved by the individual's name or other identifier assigned to the individual. A system of records subject to the Act may not be employed in the performance of this Agreement until the necessary approval and publication requirements applicable to the system have been carried out. The District or Contractor, as appropriate, agrees to correct, maintain, disseminate, and

use such records in accordance with the requirements of the Act, and to comply with all applicable requirements of the Act.

- (c) To include the Privacy Act Notification contained in this Agreement in every subcontract solicitation and in every subcontract when the performance of Work under the proposed subcontract may involve the design, development or operation of a system of records on individuals that is to be operated under the Contract to accomplish a Government function; and
- (d) To include this clause, including this paragraph in all in subcontracts under which Work for this Agreement is performed or which is awarded pursuant to this Agreement or which may involve the design, development, or operation of such a system of records on behalf of the Government.

14.2 Applicability

For purposes of the Privacy Act, when the Agreement involves the operation of a system of records on individuals to accomplish a Government function, the District, third party contractors and any of their employees are considered to be employees of the Government with respect to the Government function and the requirements of the Act, including the civil and criminal penalties for violations of the Act, are applicable except that the criminal penalties shall not apply with regard to contracts effective prior to September 27, 1975. In addition, failure to comply with the provisions of the Act or of this clause will make this Agreement subject to termination.

14.3 Definitions

The terms used in this clause have the following meanings:

- (a) "Operation of a system of records" means performance of any of the activities associated with maintaining the system of records on behalf of the Government including the collection, use and dissemination of records.
- (b) "Records" means any item, collection or grouping of information about an individual that is maintained by the District or Contractor on behalf of the Government, including, but not limited to, his education, financial transactions, medical history, and criminal or employment history and that contains his name, or the identifying number, symbol or other identifying particular assigned to the individual, such as a finger or voice print or a photograph.
- (c) "System of records" on individuals means a group of any records under the control of the District or Contractor on behalf of the Government from which information is retrieved by the name of the individual or by some identifying number, symbol or other identifying particular assigned to the individual.

15.0 PATENT RIGHTS (Applicable only to research and development contracts) If any invention, improvement or discovery of the District or contractors or subcontractors is conceived or first actually reduced to practice in the course of or under this project which invention, improvement, or discovery may be patentable under the Patent Laws of the United States of America or any foreign country, the District (with appropriate assistance of any contractor or subcontractor involved) shall immediately notify the Government (FIA) and provide a detailed report. The rights and responsibilities of the District, third party contractors and subcontractors and the Government with respect to such invention will be determined in accordance with applicable Federal laws, regulations, policies and any waivers thereof.

16.0 PROJECT SIGNS

The contractor shall erect at the site of construction, and maintain during construction, signs satisfactory to the Department of Transportation identifying the project and indicating that the Government is participating in the development of the project.

17.0 RIGHTS IN DATA (Applicable only to research and development contracts)

The term "subject data" as used herein means recorded information, whether or not copyrighted, that is delivered or specified to be delivered under this Contract. The term includes graphic or pictorial delineation in media such as drawings or photographs; text in specifications or related performance or design-type documents, machine forms such as punched cards, magnetic tape or computer memory printouts; and information retained in computer memory. Examples include, but are not limited to, engineering drawings and associated lists, specifications, standards, process sheets, manuals, technical reports, catalog item identifications and related information. The term does not include financial reports, cost analyses and similar information incidental to contract administration.

All "subject data" first produced in the performance of this Agreement shall be the sole property of the Government. The District and Contractor agree not to assert any rights at common law or equity and not to establish any claim to statutory copyright in such data. Except for its own internal use, the District and Contractor shall not publish or reproduce such data in whole or in part, or in any manner or form, nor authorize others to do so, without the written consent of the Government until such time as the Government may have released such data to the public. This restriction, however, does not apply to Agreements with academic institutions.

The District and Contractor agree to grant and do hereby grant to the Government and to its officers, agents, and employees acting within the scope of their official duties, a royalty-free, non-exclusive and irrevocable license throughout the world:

- (a) To publish, translate, reproduce, deliver, perform, use and dispose of, in any manner, any and all data not first produced or composed in the performance of this Contract but which is incorporated in the work furnished under this Contract; and
- (b) To authorize others so to do.

District and Contractor shall indemnify and save and hold harmless the Government, its officers, agents, and employees acting within the scope of their official duties against any liability, including costs and expenses, resulting from any willful or intentional violation by the District and Contractor of proprietary rights, copyrights or rights of privacy, arising out of the publication, translation, reproduction, delivery, performance, use, or disposition of any data furnished under this Contract.

Nothing contained in this clause shall imply a license to the Government under any patent or be construed as affecting the scope of any license or other right otherwise granted to the Government under any patent.

The third and fourth paragraphs under Section 19.0 above are not applicable to material furnished to the District or Contractor by the Government and incorporated in the work furnished under the Contract, provided that such incorporated material is identified by the District or Contractor at the time of delivery of such work.

In the event that the project, which is the subject of this Agreement, is not completed, for any reason whatsoever, all data generated under that project shall become subject data as defined in the Rights in Data clause in this Contract and shall be delivered as the Government may direct. This clause shall be included in all subcontracts under this Contract.

18.0 NEW RESTRICTIONS ON LOBBYING

18.1 Prohibition

- (a) Section 1352 of Title 31, U.S. Code, provides in part that no appropriated funds may be expended by the recipient of a Federal contract, grant, loan, or cooperative agreement to pay any person for influencing or attempting to influence an officer or employee of any agency, a

Member of Congress, an officer or employee of Congress, or an employee of a Member of Congress in connection with any of the following covered Federal actions: the awarding of any Federal contract, the making of any Federal grant, the making of any Federal loan, the entering into of any cooperative agreement, and the extension, continuation, renewal, amendment, or modification of any Federal contract, grant, loan, or cooperative agreement.

- (b) The prohibition does not apply as follows:
 - (i) Agency and legislative liaison by Own Employees.
 - (ii) Professional and technical services by Own Employees.
 - (iii) Reporting for Own Employees.
 - (iv) Professional and technical services by Other than Own Employees.

18.2 Disclosure

- (a) Each person who requests or receives from an agency a Federal contract shall file with that agency a certification, included in Form of Proposal or Bid Forms, that the person has not made, and will not make, any payment prohibited by Section 20.1 of this clause.
- (b) Each person who requests or receives from an agency a Federal contract shall file with that agency a disclosure form, Standard Form-L.L.L., "Disclosure of Lobbying Activities," if such person has made or has agreed to make any payment using non- appropriated funds (to include profits from any covered Federal action), which would be prohibited under Section 20.1 of this clause if paid for with appropriated funds.
- (c) Each person shall file a disclosure form at the end of each calendar quarter in which there occurs any event that requires disclosure or that materially affects the accuracy of the information contained in any disclosure form previously filed by such person under paragraph (c)(2) of this section. An event that materially affects the accuracy of the information reported includes:
 - (i) a cumulative increase of \$25,000 or more in the amount paid or expected to be paid for influencing or attempting to influence a covered Federal action; or
 - (ii) a change in the person(s) or individual(s) influencing or attempting to influence a covered Federal action; or
 - (iii) a change in the officer(s), employee(s), or Member(s) contacted to influence or attempt to influence a covered Federal action.
- (d) Any person who requests or receives from a person referred to in paragraph (c)(i) of this section a subcontract exceeding \$100,000 at any tier under a Federal contract shall file a certification, and a disclosure form, if required, to the next tier above.
- (e) All disclosure forms, but not certifications, shall be forwarded from tier to tier until received by the person referred to in paragraph (c)(i) of this section. That person shall forward all disclosure forms to the agency.

18.3 Agreement

In accepting any contract resulting from this solicitation, the person submitting the offer agrees not to make any payment prohibited by this clause.

18.4 Penalties

- (a) Any person who makes an expenditure prohibited under Section 20.1 of this clause shall be subject to a civil penalty of not less than \$10,000 for each such expenditure.
- (b) Any person who fails to file or amend the disclosure form to be filed or amended if required by this clause, shall be subject to a civil penalty of not less than \$10,000 and not more than \$100,000 for each such failure
- (c) Contractors may rely without liability on the representations made by their sub- contractors in the certification and disclosure form.

18.5 Cost Allowability

Nothing in this clause is to be interpreted to make allowable or reasonable any costs which would be unallowable or unreasonable in accordance with Part 31 of the Federal Acquisition Regulation. Conversely, costs made specifically unallowable by the requirements in this clause will not be made allowable under any of the provisions of Part 31 of the Federal Acquisition Regulation.

19.0 SUSPENSION OF WORK DURING ALERTS ISSUED BY HOMELAND SECURITY ADVISORY SYSTEM

When the Federal Homeland Security Advisory System (HSAS) or the Federal Transit Administration (FTA) issues a Threat Condition Alert Orange (high risk of terrorist attack), Threat Condition Alert Red (severe risk of terrorist attack), Threat Condition Alert Black (under attack), Threat Condition Alert Purple (recovery following attack), the District shall have the right to suspend or delay completion of work under this Contract and take additional action as the District deems necessary to secure the District's facilities as follows:

Threat Condition Orange: the District shall have the right to delay or suspend all non-vital facilities work, as determined in its sole discretion, monitor all work areas and Contractor's personnel and equipment entering work areas.

Threat Condition Red: the District shall have the right to suspend all non-critical maintenance and capital work, as determined in its sole discretion, and to restrict or deny access to work areas.

Threat Condition Black and Threat Condition Purple: the District shall suspend all maintenance and capital work until further notice.

The District shall provide notice to the Contractor, as soon as possible, of the receipt of a Threat Condition Alert and the effect such alert will have upon the work of the Contractor. To facilitate the provision of such notice, the Contractor is required to provide the Program Manager with emergency contact information in the form of cell phone numbers and e-mail addresses to which such notices may be forwarded, and to keep said numbers current. Notice or attempted notice given to the most recent points of contact shall be deemed to be sufficient notice to Contractor that work shall be delayed or suspended in accordance with this paragraph. Any delay or suspension of work required under this paragraph shall not entitle Contractor to any claims for additional compensation under this contract.

20.0 IDENTIFICATION OF PERSONNEL; SECURITY

The Contractor shall provide personnel who enter upon the District's property with distinctive identification badges showing the employer's name, the employee's name, the employee's job title, and any employee identification number assigned to such employee. All personnel shall display these badges prominently upon their persons while on District's property. The District will allow only properly certified personnel of the Contractor on its property. The District shall have the right to require the Contractor to conduct background checks on its employees and to remove from the District's any employee the District considers incompetent, careless, or who constitutes a security risk or safety hazard.

PART VIII

SANTA CRUZ METROPOLITAN TRANSIT DISTRICT PROTEST PROCEDURE

PROCUREMENT PROTESTS

All protests shall be filed, handled and resolved in a manner consistent with the requirements of Federal Transit Administration (FTA) Circular 4220.1E Third Party Contracting Guidelines dated June 19, 2003 and the Santa Cruz Metropolitan Transit District's (District) Protest Procedures which are on file and available upon request.

Current FTA Policy states that: "Reviews of protests by FTA will be limited to:

- (1) a grantee's failure to have or follow its protest procedures, or its failure to review a complaint or protest; or
- (2) violation of Federal law or regulation.

An appeal to FTA must be received by the cognizant FTA regional or Headquarters Office within five (5) working days of the date the protester learned or should have learned of an adverse decision by the grantee or other basis of appeal to FTA" (FTA Circular 4220.1E, Section 7, paragraph 1., Written Protest Procedures)

Protests relating to the content of this Invitation for Bid (IFB) package must be filed within ten (10) calendar days after the date the IFB is first advertised. Protests relating to a recommendation for award solicited by this IFB must be filed by an interested party within five (5) calendar days after the staff's written recommendation and notice of intent to award is issued to the bidders. The date of filing shall be the date of receipt of protests or appeals by the DISTRICT.

All Protests shall be filed in writing with the Assistant General Manager, Santa Cruz Metropolitan Transit District, 370 Encinal Street, Suite 100, Santa Cruz, CA 95060 **No other location shall be acceptable.** The DISTRICT will respond in detail to each substantive issue raised in the protest. The Assistant General Manager shall make a determination on the protest normally within ten (10) working days from receipt of protest. Any decision rendered by the Assistant General Manager may be appealed to the Board of Directors. The Protester has the right within five (5) working days of receipt of determination to file an appeal restating the basis of the protest and the grounds of the appeal. In the appeal, the Protester shall only be permitted to raise factual information previously provided in the protest or discovered subsequent to the Assistant General Manager's decision and directly related to the grounds of the protest. The Board of Directors has the authority to make a final determination and the Board of Director's decision shall constitute the DISTRICT's final administrative remedy.

In the event the protestor is not satisfied with the DISTRICT's final administrative determination, they may proceed within 90 days of the final decision to State Court for judicial relief. The Superior Court of the State of California for the County of Santa Cruz is the appropriate judicial authority having jurisdiction over Bid Protest(s) and Appeal(s). Bid includes the term "offer" or "proposal" as used in the context of negotiated procurements.

The Bidder may withdraw its protest or appeal at any time before the DISTRICT issues a final decision.

Should the DISTRICT postpone the date of bid submission owing to a protest or appeal of the solicitation specifications, addenda, dates or any other issue relating to this procurement, the DISTRICT shall notify, via addendum, all parties who are on record as having obtained a copy of the solicitation documents that an appeal/protest had been filed, and the due date for bid submission shall be postponed until the DISTRICT has issued its final decision.

A letter of protest must set forth the grounds for protest and shall be fully supported with technical data, test results, or other pertinent information related to the subject being protested. The Protestor is responsible for adhering to the DISTRICT's protest procedures.

A Bidder may seek FIA review of the DISTRICT's decision. A protest appeal to the FIA must be filed in accordance with the provisions of FIA circular 4220.1E. Any appeal to the FIA shall be made not later than five (5) working days after a final decision is rendered under the DISTRICT's protest procedure. Protest appeals should be filed with:

Federal Transit Administration
Regional Administrator Region IX
201 Mission Street, Suite 2210
San Francisco, CA 94105-1839

SANTA CRUZ METROPOLITAN TRANSIT DISTRICT

Invitation for Bids (IFB)

**For Demolition of Old Bus Wash Area at
1200 River Street, Santa Cruz**

District IFB No. 09-01

ATTACHMENT A

Project Drawings



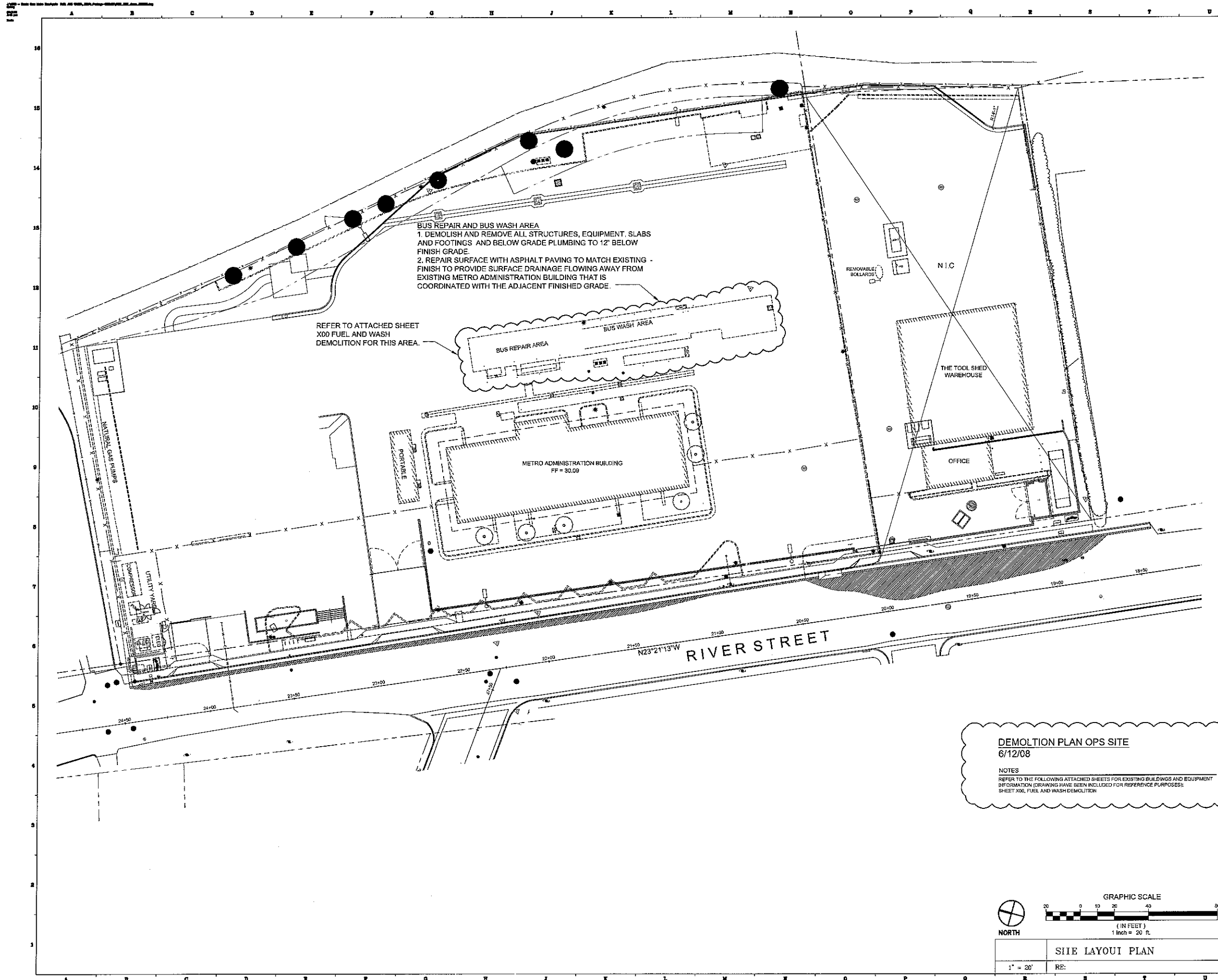

BUS REPAIR AND BUS WASH AREA
 1. DEMOLISH AND REMOVE ALL STRUCTURES, EQUIPMENT, SLABS AND FOOTINGS AND BELOW GRADE PLUMBING TO 12" BELOW FINISH GRADE.
 2. REPAIR SURFACE WITH ASPHALT PAVING TO MATCH EXISTING FINISH TO PROVIDE SURFACE DRAINAGE FLOWING AWAY FROM EXISTING METRO ADMINISTRATION BUILDING THAT IS COORDINATED WITH THE ADJACENT FINISHED GRADE.

REFER TO ATTACHED SHEET X00 FUEL AND WASH DEMOLITION FOR THIS AREA.

DEMOLITION PLAN OPS SITE
 6/12/08

NOTES
 REFER TO THE FOLLOWING ATTACHED SHEETS FOR EXISTING BUILDINGS AND EQUIPMENT INFORMATION (DRAWING HAVE BEEN INCLUDED FOR REFERENCE PURPOSES):
 SHEET X00, FUEL AND WASH DEMOLITION

KEY PLAN

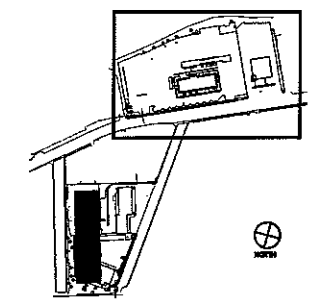

CONSTRUCTION NOTES

BID SET

No.	Revision / Substitution	Date

Merrill Miller Engineering, Inc.
 Civil and Structural Engineering
 1000 Highway 101, Suite 100
 San Jose, CA 95128
 Tel: 408.298.1111
 Fax: 408.298.1112
 www.merrillmiller.com

RNL DESIGN
 Architects and Engineers
 1000 Highway 101, Suite 100
 San Jose, CA 95128
 Tel: 408.298.1111
 Fax: 408.298.1112
 www.rnldesign.com

SANTA CRUZ METROPOLITAN TRANSIT DISTRICT
 370 ENCINAL STREET, SUITE 100
 SANTA CRUZ, CA 95060

SITE LAYOUT PLAN
 RIVER STREET SITE

Designed:	Project Number:
Drawn:	Scale:
Checked:	Drawing Number:
Reviewed:	C101
Date:	of

GRAPHIC SCALE
 (IN FEET)
 1" = 20'

1" = 20'

SITE LAYOUT PLAN

RE: _____

2 DEMOLITION PLAN - SITE PHOTO KEYS
1/8" = 1'-0"

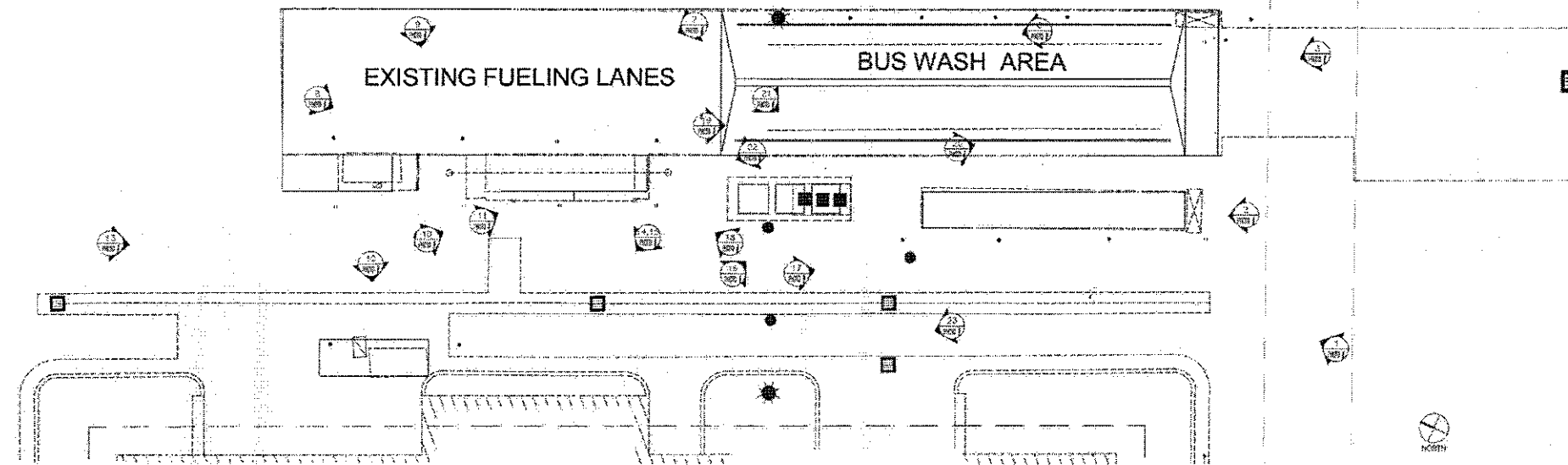

1 DEMOLITION PLAN
1/8" = 1'-0"

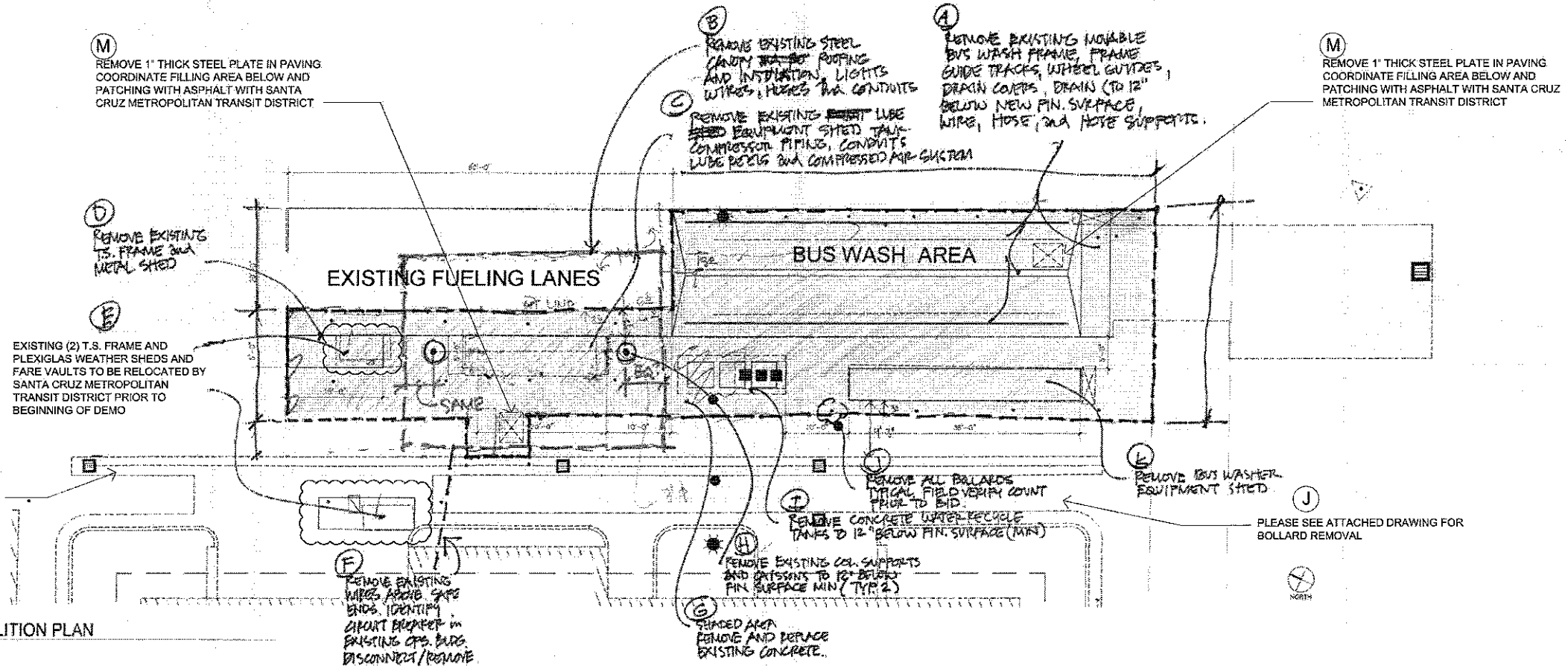

	SUBCONSULTANTS LIST CONSULTANT ADDRESS	SANTA CRUZ METROPOLITAN TRANSIT DISTRICT	Drawing Title		Project Title		Date	
			Approved Director, Office of Construction Management		FUEL AND WASH DEMOLITION		6/12/08	
Approved Director, Project Management Service			Building Number		Checked		Drawn	
Location 1200 RIVER STREET SANTA CRUZ, CA 95060			Drawing No.		Project No.		6040-1595-01	
Revisions			Date		X00		2x2 OF	

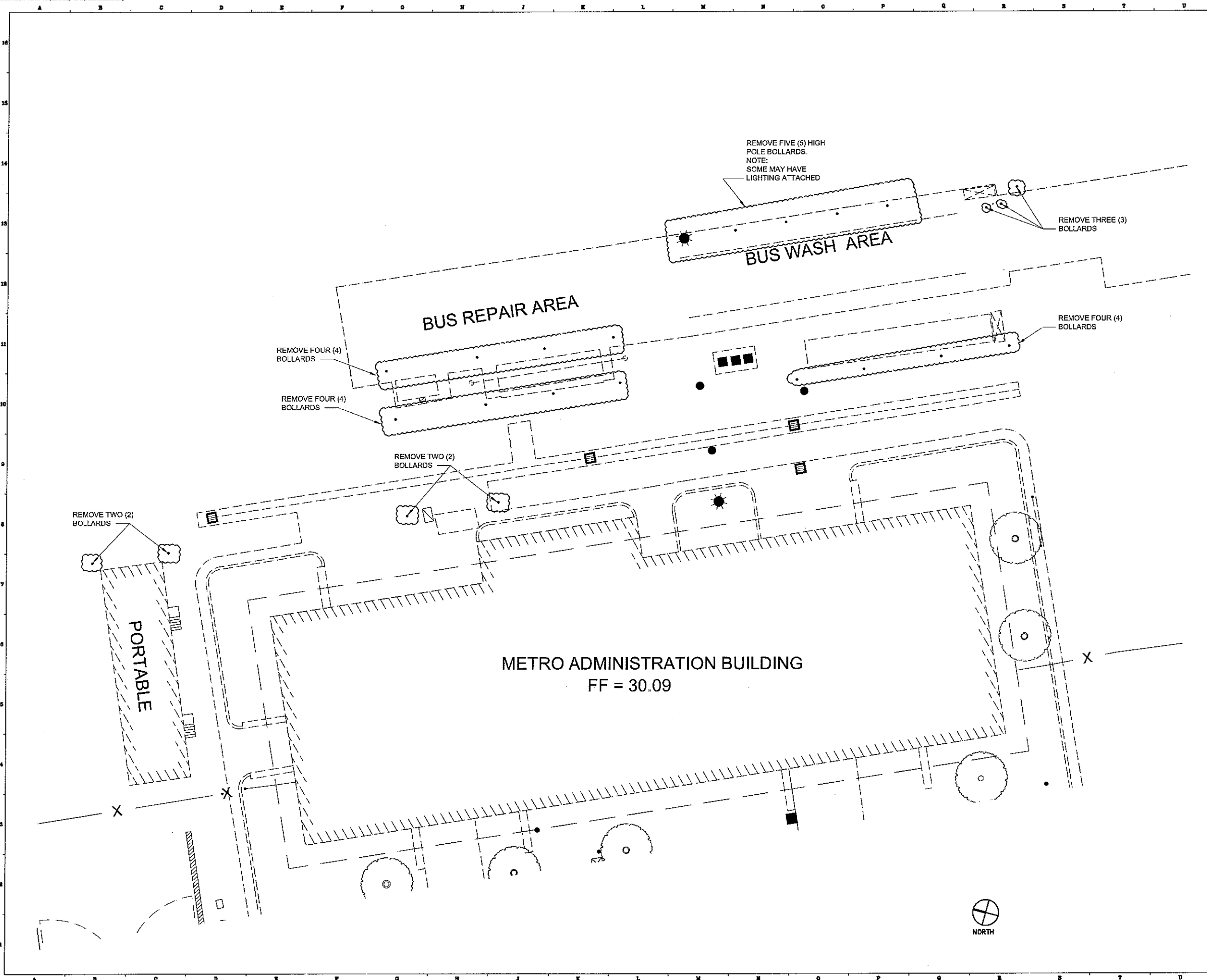

KEY PLAN

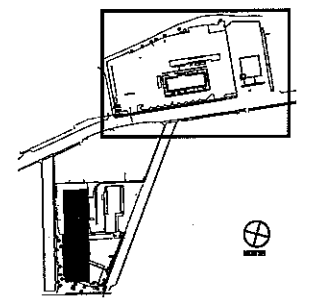

CONSTRUCTION NOTES

REMOVE FIVE (5) HIGH POLE BOLLARDS.
NOTE: SOME MAY HAVE LIGHTING ATTACHED

REMOVE THREE (3) BOLLARDS

REMOVE FOUR (4) BOLLARDS

REMOVE FOUR (4) BOLLARDS

REMOVE TWO (2) BOLLARDS

REMOVE TWO (2) BOLLARDS

BID SET

No	Revision / Submittals	Date

RNL DESIGN

Architectural
Interior Design
Engineering
Facility Planning
Urban Design
Landscape Architecture

1000 North Zanker Road
Santa Cruz, CA 95060
408.298.1234

SANTA CRUZ METROPOLITAN TRANSIT DISTRICT

370 ENGICAL STREET, SUITE 100
SANTA CRUZ, CA 95060

**DEMOLITION PLAN
BOLLARD REMOVAL**

Designed:	Project Number:
Drawn:	Scale:
Checked:	Drawing Number:
Reviewed:	X01
Date:	of

© 2008 RNL Design, Inc. All rights reserved. This drawing is the property of RNL Design, Inc. and is not to be used, copied, or reproduced in any form without the written permission of RNL Design, Inc.



ADDENDUM NO. 1

Date of Issue: November 20, 2008

Invitation for Bids (IFB) No. 09-01

**SANTA CRUZ METROPOLITAN TRANSIT DISTRICT
For Demolition of the Old Bus Wash Area at 1200 River Street**

BID DUE: December 5, 2008 @ 2:00 PM, PST

Notice is hereby given that the Santa Cruz Metropolitan Transit District, Santa Cruz, State of California is providing the following clarifications, modifications, additions and / or deletions to the Invitation for Bids (IFB) No. 09-01 for Demolition of Old Bus Wash Area at 1200 River Street. This Addendum shall become a part of the original IFB as issued by the Santa Cruz Metropolitan Transit District and the bid date and time remain unchanged at December 5, 2008 @ 2:00 PM, PST.

Receipt of this Addendum No. 1 shall be acknowledged in your bid response. Any adjustment resulting from this addendum shall be included in the IFB. Where in conflict, the terms and conditions of this addendum supersede those in the Invitation for Bid.

All questions concerning this Addendum shall be referred to Lloyd Longnecker, Purchasing Agent at 370 Encinal Street, Suite 100, Santa Cruz, CA 95060, (831) 426-0199 Voice, (831) 423-2918 Fax, or email address llongnecker@scmttd.com.

This Addendum forms a part of the Contract Documents, and modifies the following as noted below:

1. ADDENDUM CONTENT:

1.1 Addendum No. 1: 17 pages -plus Attachments:

- Attachment A: The minutes of the pre-bid meeting conducted on November 5, 2008 with the list of attendees.
- Attachment B: The current plan holder's list.
- Attachment C: Sample Bond Forms
- Attachment D: Revised Drawing C101 for concrete area not to be removed

2. CHANGES TO PREVIOUS ADDENDA: (None)

3. BIDDERS REQUESTS FOR CLARIFICATIONS:

3.1 The bid does not address removal of oil and lubricant contamination of the sheds, bus wash equipment (external and hydraulics system) and surrounding concrete. How will they be managed?

Addendum No. 1 – Issue: November 19, 2008

Answer: METRO is having a hazardous materials survey performed for this project. Contractor will be required to remove any materials found.

3.2 Could you let us know if the monitoring well will be preserved, abandoned or destroyed?

Answer: Abandon if any found.

3.3 This is a lump sum bid, however, disposal /recycling of construction debris is involved. How do we account for those costs when they are variable?

Answer: Based on the specifications, drawings and review of the job site, bidder to provide a lump sum bid as requested and should indicate in an attached sheet to their bid the cost per yard for the types of materials to be removed.

3.4 Could you please clarify what the DBE goal or requirement is?

Answer: METRO has an annual DBE Participation goal of 1.32% for Federally funded procurements. Please refer to Part II, Article 18 for Bidder requirements in regards to DBE firms.

3.5 Clarify which schedule of prevailing wages apply?

Answer: As stated in Part II Instructions to Bidders, Article 22. Prevailing Wages, bidder should visit the web site listed and review the job categories that would apply to this project.

3.6 Please clarify what each bidder submittal package should consist of. There are some areas in the scope of work that mention submittal; and are not clear as to whether this is for awardees or bidders.

Answer: No submittals are required only coordination with Owner.

3.7 Does Section 11. "Prompt Payment" in the General Conditions of the Contract still apply if the awarded contractor already has agreements/contracts in place with their subcontractors that allow payment terms greater than 30 days?

Answer: Invoice work per month for Owner review.

3.8 We wish to obtain the proper bonding for this project, but did not find the bond forms in the specs sent. Is there a sample form you require to be used?

Answer: See Attachment C for sample bonding forms.

3.9 Are there now considerations for the hydraulic lines on the bus wash system. And if there is hazardous waste generated who will manage it?

Answer: Coordinate with Owner if hazardous waste is generated. Cost proposal for work to be submitted to Owner.

3.10 Are there now considerations for the motor oil and other lines for filling the buses on the shed?

Answer: Coordinate with Owner if hazardous waste is generated. Cost proposal for work to be submitted to Owner.

4. CHANGES TO IFB TERMS AND CONDITIONS:

4.1 Revision to Part III, Section 01100 – Summary, Item 1.03 WORK COVERED BY CONTRACT DOCUMENTS, D, Revise as follows:

Addendum No. 1 – Issue: November 19, 2008

- D. The Work consists of a waste management plan, temporary fencing (~~which will remain beyond contract completion under a lease transfer agreement to the District~~), removal of identified hazardous materials, demolition of above and below grade construction elements, capping in place of existing utilities, and sandbagging to prevent runoff of demolition-created exposed silt.
- I. The Work includes:
 - a. Temporary site fencing
 - b. Clearing of bus wash structure, canopy and related sheds.
 - c. Recommended removal of identified hazardous materials.
 - d. Preparation and execution of a waste management plan with goal to recycle/salvage 50% of the demolition volume.
 - e. Demolition of above and below grade structures.
 - f. ~~Level Filling of demolished footprint and foundation removal soil depressions with broken concrete to within 6" of the adjacent driving surfaces.~~
 - g. Removal from site of all salvage and demolition waste.
 - h. **Remove and properly dispose of 12' x 42' trailer located adjacent to the bus wash area.**

4.2 Revision to Part III, Section 02221, part 2 Execution, Article 2.09 Recycling Demolished Materials, item D, **Revise** as follows:

- D. Concrete: Remove reinforcement and other metals from concrete and sort with other metals. **Pulverize concrete to maximum 4-inch size. Remove and properly dispose of all materials from the site.**

Please Note: *All other terms and conditions of the IFB dated October 24, 2008 remain unchanged.*

END OF ADDENDUM NO. 1

ATTACHMENT A

Minutes - IFB No. 09-01 Demolition of Old Bus Wash Area Pre-Bid Meeting November 5, 2008

A Pre-Bid meeting for IFB No. 09-01, for the demolition of the old bus wash area at 1200 River Street, Santa Cruz was held at the District's Purchasing Office Conference Room located at 110B Vernon Street in Santa Cruz, on Wednesday, November 5, 2008 at 1:30 p.m.

1. CALL TO ORDER

Lloyd Longnecker called the meeting to order at 1:30 p.m.

PRESENT

Lloyd Longnecker, Purchasing Agent
Frank Cheng, MetroBase Project Agent
Sean McHugh and Darren McCardle of Jos. J. Albanese, Inc.
Michael Collier and Vinnie Kalsi of Clean Harbors Environmental Services
Kurt Nicholson of Mark Nicholson, Inc.
Alessandro Hnah and Duncan Geddes of ADH Environmental
Brent Henningsen of Henningsen Construction Company, Inc
Julia Davidson of Granite Construction
Tom Pieras of A & S Demolition
Ken Hopper of Randazzo Enterprises
Aldolfo Garcia of Community Tree Service
Robert Feaban of WC Maloney Inc.
Harold Mendoza of NICA DMT, Inc.

Lloyd Longnecker: Welcome everyone, this is the pre-bid meeting for METRO's Invitation for Bid No. 09-01 for demolition of the old bus wash area at 1200 River Street. My name is Lloyd Longnecker and I am the Purchasing Agent for the District. This is Frank Cheng who is the MetroBase project manager. This job requires the demolition of the old bus wash area at our Operations Yard. There is a canopied roof, metal sheds, and several bollards that must be removed. There is an area of concrete that must be removed and the cleared area of the job site will then be repaved with asphalt.

The minutes of this meeting will be included in the first addendum hopefully the only addendum, so I would like any written questions you have by November 14th. You can either fax them to the number that is listed on this agenda; it's also listed on the bid packet or email it to me at the address listed as well. A lot easier to work with email if you can do that, but anyway November 14th we'd like to get your questions and then we'll try to get them out by the 19th, which will be the first addendum.

Bids are due on December 5th at 2:00 p. m. This is a public bid opening, so we will open them at that time. If you want to attend please do so, but just make sure you get your bid in before that time. Tentatively we're hoping to get the Board of Directors approval of any contract by December 19th. After getting signed contracts the successful contractor will get a notice to proceed on January 1st or the day after. Hopefully get this project can be accomplished within a thirty day period or attempt to, Mother Nature willing here.

Frank Cheng: The only thing, before the work gets started is to coordinate with me what items need to be removed, trying to coordinate with bus operations to make sure the buses are able to get out of there.

Lloyd Longnecker: You have to work around the yard in Operations as well. Most pullouts happen in the early morning and come back in the late evening. There is an operation going on all day long, so you're going to have to work with that. It's probably the only trick to the whole project, is to work around them. The facilities manager did ask me when we get down there to kind of give us an guess estimate of what kind of foot print you're going to use to fence off the area so he can see how much parking he is not going

ATTACHMENT A

to have. Parking is a big premium with us right now. It's scattered everywhere at night including the corporation yard for the city, we use their parking lot at night. We're stuck for space, but with that being said hopefully we can get it cleared out and get a little extra parking for the buses in the evening. This leads up to a project that is tentatively scheduled to go out in the first of the year, which is our new Operations building. It is about a twenty-two million dollar project.

Frank Cheng: It will be a two story-parking garage with two-story offices. It looks like three-stories, but it is a budget of twenty-two million with a twenty-two month construction period. The staging for this is very complicated and that's why there is a demolition project that you are here for, it will help alleviate part of that. It's still going to be complicated, but make it simple.

Lloyd Longnecker: So that's it I hope everybody at least signed an attendance sheet. I will also provide that information in the first addendum along with a list of current plan holders list. Is there anybody here that doesn't have a copy of the bid package, because I thought I received a couple of phone calls from somebody? Okay I'll get you one in just a minute here. I guess at this point I'd open it up for questions. This will be the one time you don't have to submit written questions, because we'll take it here and then if we can't respond to it we'll get back to you in the first addendum.

Speaker: When are you going to issue the first addendum?

Lloyd Longnecker: We are going to respond by November 19th, if we get questions by the 14th.

Lloyd Longnecker: I don't know if it was published, but our estimate on the project is twenty-five thousand.

Speaker: You've got some asphalt repairs, are there asphalt specifications? I haven't really looked for one.

Lloyd Longnecker: Oh, yeah it's in Part III of the spec package. If you go to the page number that is part III-8, Flexible Pavement.

Lloyd Longnecker: On page 2 of Part III there is an item D at the top there's a statement that talks about temporary fencing, which will only mean beyond contract completion under our lease transfer agreement to the district that will be deleted in the first addendum. That was from a previous demolition bid that we had that we forgot to strike. There will be a need for temporary fencing, but we're not going to lease it back. When you're done with the project, please have it removed.

Speaker: Regarding that same item D, down to f. Level filling of demolished footprint foundation removal for all depressions with broken concrete to within 6" of the adjacent driving surfaces. Do we fill in the hole with broken concrete?

Frank Cheng: No, we'll be removing all the concrete so there will be ...

Speaker: You're removing the concrete?

Lloyd Longnecker: No you are.

Frank Cheng: Yes so that will be taken out.

Lloyd Longnecker: So, again that will be clarified in the addendum.

Speaker: Okay.

Lloyd Longnecker: Any other questions?

Speaker: Is something abated? (unintelligible)

Lloyd Longnecker: Sorry?

ATTACHMENT A

Speaker: (unintelligible)

Frank Cheng: No abatement. Demolition.

Lloyd Longnecker: Right just demolition and repaving.

Speaker: So everything has been abated then?

Lloyd Longnecker: There are a few things that, you mean inside the sheds?

Speaker: Hazardous materials, asbestos, anything?

Frank Cheng: No asbestos, it's just a metal structure.

Speaker: Has anybody done a report yet or would the contractor have to do it or is that going to be done by you?

Speaker: Not painted with lead and asbestos (unintelligible).

Lloyd Longnecker: No it's just a steel shed. It's got some plumbing in there, but there's nothing that covered on the plumbing. Those questions will be answered when we see it. Really there's not much to this job.

Lloyd Longnecker: Of course because this is a public project and it's valued over ten thousand dollars prevailing wage rates would apply.

Speaker: Part 3 page 7 pulverize concrete to maximum 4-inch size. Is that a requirement or do we take to disposal?

Lloyd Longnecker: 3, 7 what item now?

Speaker: Part 3 page 7 item 2.09 item D. Remove reinforcement and other metals from concrete and sort with other metals. Pulverize concrete to maximum 4-inch size. Is that a requirement or do we take to disposal?

Lloyd Longnecker: The answer to that is yes get rid of it.

Speaker: Okay.

Frank Cheng: That will come out in the addendum.

Lloyd Longnecker: Yes we'll respond to that.

Speaker: 50% Recycle is 50%, you're not looking at anything to be salvaged removed for site and recycled?

Lloyd Longnecker: That's right.

Speaker: Line E of that same section, masonry, pulverize masonry, you said you used a previous demolition bid specification,

Lloyd Longnecker: Yeah we did. I don't think there is any masonry down there. We're just covering all bases, there are some specs in here that are covered just in case, but it's probably not going to show.

Lloyd Longnecker: Any other questions?

ATTACHMENT A

Speaker: Are there utility disconnects, light poles, electrical?

Lloyd Longnecker: It's in the spec, but there are just a couple of spots where you probably have to verify overhead light of course. I'm not sure of our guys have disconnected them yet or not.

Frank Cheng: Yeah I haven't verified that. I know that we've removed things that we want to keep. We've already moved stuff from that area, but I'm not sure about the electrical whether it's connected or not.

Speaker: Is there (unintelligible).

Frank Cheng: Not yet.

Speaker: It's really difficult to disconnect all utilities and plumbing and fire prior to the demolition of it.

Lloyd Longnecker: If we do disconnect I think it's at the circuit breaker.

Speaker: Do you guys have requirements for things like fencing and erosion control and water run off and stuff? I know the San Lorenzo is right there, is there issues associated with that that need to be addressed as part of this project.

Lloyd Longnecker: Yeah, I believe we covered some of that in the spec. Have you seen the package yet?

Speaker: I've seen the package, but I haven't been through it any great detail yet.

Lloyd Longnecker: Okay check out part three and then if you have any questions on that since you were late coming here.

Speaker: Sorry about that.

Lloyd Longnecker: That's all right. Other than today everything comes in writing, either faxed or emailed and then I'll include that in our first addendum, which we hope to have out by the 19th of November, along with the minutes of this meeting.

Speaker: Okay.

Lloyd Longnecker: Okay. And a copy of the attendance list and the list of current plan holders.

Speaker: Put down again.

Lloyd Longnecker: Yes

Speaker: And forgive me for talking from ignorance and the last question are the plan sets available and where would we pick them up?

Lloyd Longnecker: I have a couple of extra sets here and I would be glad to give you one. I just want to make sure I get your company name and address.

Speaker: Sure absolutely. Is there... I'm going to keep going. Is there soil contamination or water contamination that I need to worry about, we need to worry about?

Lloyd Longnecker: I hope not.

Speaker: We all hope that believe me I'm just asking.

Lloyd Longnecker: History was an old fueling station along time ago. Those things have been removed a long time ago. We haven't done fueling on this site I want to say before the "89 Earthquake". We had a

ATTACHMENT A

huge facility in Watsonville that performed most of the fueling which got destroyed in the quake, but we've been going off site ever since for fueling. The only thing that we have that's out of that time now is.

Speaker: So there's no reason necessarily to expect that there are.

Lloyd Longnecker: No.

Speaker: So we'll have to deal with it if we find it, but it'll all work if we don't.

Lloyd Longnecker: You're right.

Speaker: There wasn't a soils report or sampling requirement?

Lloyd Longnecker: A sampling requirement? No I don't think there was one.

Speaker: Is there a geotechnical engineer on this project specifically or not?

Lloyd Longnecker and Frank Cheng: No.

Speaker: There is not one on this project? Is it our responsibility to hire one for parts compaction on the base rock and asphalt is there any testing?

Frank Cheng: There is no testing required but contractor must comply with the construction specification.

Speaker: We don't do test any of the base compaction or asphalt?

Frank Cheng: No because all of this is going to be temporary. Probably we'll be using it for I guess maybe a year, then demolish the whole thing and put concrete on it.

Speaker: (unintelligible)

Lloyd Longnecker: Look on the wall behind you. That's kind of the current set up of the building now, the Operations building, the bottom of it being River Street. The new building is going to be to the lower left corner of the property. So that whole area is going to be demolished once we move into the new building and replace with concrete. So that is going to encompass probably a lot of the area that you're going to be working on anyway.

Speaker: Is there going to be much stuff to make the excavation necessary? And are they taking out and putting some things like that I'd imagine. Is there anything like that?

Lloyd Longnecker: I think the deepest is the concrete, but it's set for the bus wash station because they have the heavy buses rolling through there.

Speaker: (unintelligible)

Lloyd Longnecker: No.

Speaker: I'm just worrying about near the river ground water issues.

Lloyd Longnecker: Oh, your going to hit ground water. It come up very easy there. The foundations for the new building are really an engineering exercise. They will drill down fifty feet or more or something like that.

Speaker: Oh so its got deep piers in the foundation. Are those coming out or how's...

Lloyd Longnecker: No this is for the construction of the new building.

ATTACHMENT A

Frank Cheng: That is correct.

Speaker: Three feet or something like that

Frank Cheng: Our product that we put in our facility the one that you see all the way on the right those were seventy foot piles. 16 x 16 piles straight down so that they can hit bedrock at fifty feet and probably get twenty feet into the bedrock. A lot of them ended up at thirty and forty range

Speaker: Okay so it varies across the line

Frank Cheng: So it varies across the line.

Speaker: So it's not anything we really have to worry about

Frank Cheng: Correct, any other questions?

Speaker: Lets go so the job.

Lloyd Longnecker: Ok, lets go see the job site.

2. ADJOURN

The meeting adjourned at approximately 2:15 pm.

Respectfully submitted,

Karen Blight

Administrative Assistant

3. Site Questions

1. Are there any underground tanks (oil/grease separators, 1000 gallon concrete tanks)?
Answer: No
2. If there are any tanks would the Contractor be responsible for pumping out the tank and removal of any waste?
Answer: There are no tanks.
3. Has there been a hazardous waste study on this project (asbestos, etc.)?
Answer: METRO is having a hazardous waste survey performed before this contract will be issued.
4. How deep are the concrete foundations for the roof supports?
Answer: That information is unknown at this time.
5. Remove concrete all the way to the catch basin?
Answer: See attachment D for revised drawing C101 for concrete area not in contract..
6. Are there concrete saw cutting requirements?
Answer: Only at the end of the bus washer as indicated in the revised drawing (Attachment D).

ATTACHMENT A

7. What about water and electric connections?

Answer: Water has been disconnected at the Operations Building outside wall. There is a vault just outside the Operations Building wall that gives access to disconnect the electrical.

8. Permits and fees?

Answer: To the extent permit and licensing requirements are applicable, the contractor shall procure all permits and licenses not procured by METRO and required by the project, pay all charges and fees, and give all notices necessary and incident to the due and lawful prosecution of the work.

ATTACHMENT B

List of Plan Holders for this project.

09-01 Demolition of Bus Wash Area
Due: December 5, 2008, 2 PM

Coastwide Environmental Technologies
201 Walker Street
Watsonville CA 95076

Monteith Construction Inc.
P O Box 572
Felton CA 95018

NICA DMT INCORPORATED
Harold Mendoza
101 North Greenville Rd

Livermore CA 94551-5803

RANDAZZO ENTERPRISES
13550 Blackie Rd
Castroville CA 95012-3200

Ginochio Excavating
100 Lagunita Dr
Soquel CA 95073

ADH Environmental
3550 North Main Street
Soquel CA 95073

WC Maloney
PO Box 30326
Stockton CA 95213-0326

HSR INC.
530 Aldo Ave
Santa Clara CA 95054

HAZMAT SOLUTIONS INC
1113 1st St
Novato CA 94945-2403

~~Bindel Bros., Inc.
525 Ortiz Ave
Sand City CA 93955~~

A & S Metals
11340 Commercial Way
Castroville CA 95012

Sent Letter – No Bid this Project

PAVEX CONSTR
411 Walker St
Watsonville CA 95076-4225

~~Carpenter Excavation
518 W 4th Street
Chico CA 95928~~
Bid Returned-unable to forward

Buccaneer Demolition
618 S. First Co
San Jose CA 95113

~~Bay Cities Service
1745 Esperanza Ct
Santa Cruz CA 95062~~

Evan Bros. Inc.
Chris Geiss
7589 National Dr
Livermore CA 94550

Carpenters Union
225 Searidge Road
Aptos CA 95003

Bid Returned-unable to forward

~~Cal Demo
9515 Soquel Dr #212
Aptos CA 95003~~

MS Services
1190 Lincoln Ave #2
San Jose CA 95125

Earth Moving & Demolition, Inc.
P O Box 1540
Bryon CA 94514

Bid Returned-unable to forward

Olcese Construction
PO Box 5682
Incline Village NV 89450

PJB Demo
PO Box 1114
Freedom CA 95019

Bluewater Services, Inc.
2075 Williams Street
San Leandro CA 94577

PENHALL CO
696 Walsh Ave
Santa Clara CA 95050-2628

T.M. Sweatt
1518 Pyramid Ct
San Jose CA 95130

Henningsen Construction Co., Inc.
P O Box 7477
Spreckels CA 93962

ATTACHMENT B

Reber Construction
PO Box 273
Santa Cruz CA 95060

Roldan Construction, Inc.
4607 Enterprise Common
Fremont CA 94538

Cleveland Wrecking Company
Alicia Gaddis
628 East Edna Place
Covina CA 91723

Bayline Demolition, Inc.
P O Box 23464
San Jose CA 95153

Ferma Corporation
1265 Montecito Ave
Suite 200
Mountain View CA 94043-4506

Geofon, Inc.
Barbara Stevens
22632 Golden Springs Drive, Suite 270
Diamond Bar CA 91765

ACS
P O Box 2465
Hollister CA 95024

Community Tree Service and
Demolition
320 Industrial Road
Watsonville CA 95076

Santa Cruz Builders Exchange
1248 Thompson Ave
Santa Cruz CA 95062

Builders Exchange of the
Central Coast
100 12th St bldg 2861
Marina CA 93933

Earthworks
310-A Kennedy Drive
Capitola CA 95010

Granite Construction Co
P O Box 720
Watsonville CA 95077

Mimi Zavala
McGraw Hill Construction Dodge
1333 S. Mayflower Suite 300
Monrovia CA 91016

Michael Lunan
Reed Construction Data
30 Technology Pkwy S, Ste 500
Norcross, GA 30092

Salinas Valley Builders Exchange
20 Quail Run Circle #A
Salinas, CA. 93907

Edwin Sargenti
PSC Industrial Services
Division-Demolition
P.O. Box 431
62117 Railroad Ave
San Ardo, CA 93450

Nicole Bryant
Bureau Veritas North America, Inc.
1565 MacArthur Boulevard
Costa Mesa, CA 92626

Karen Blanchard
Zaccor Companies, Inc
PO Box 590
Alameda, CA 94501

Sara Orrick, Partner
Pacific Underground Services
3881 Martha Drive
Martinez CA 94553-3026

Vinnie Kalsi
Clean Harbors Environmental Services
1030 Commercial Street, Suite 107
San Jose, CA 95112

Sean McHugh
Jos. J. Albanese, Inc.
988 Walsh Avenue
Santa Clara CA 95050

Mark Nicholson, Inc.
P O Box 58
Hollister, CA 95024

Victor Chavez
P & C Demo and Construction
2160 California Ave, Ste B-225
Sand City CA 93955

Edwin Sargenti
PSC
P O Box 431
San Ardo CA 93450
esargenti@PSCNow.com

Machado Brothers, Inc.
1005 Spring Hill Road
Petaluma, Ca 94952

Bellicitti & Pellicciotti
Construction Company, Inc.
P.O. Box 606
Santa Clara, CA 95052-0606

Jeff Manely
Universal Structures
9920 Equestrian Place
Salinas CA 93907

ATTACHMENT C

SAMPLE BOND FORMS ATTACHED

BIDDER'S BOND

PAYMENT BOND

PERFORMANCE BOND

ATTACHMENT C

BIDDER'S BOND

(To be submitted with Bid)

KNOW ALL PERSONS BY THESE PRESENT:

THAT WE
as PRINCIPAL, and

as SURETY, are held and firmly bound unto the Santa Cruz Metropolitan Transit District in the penal sum of **FIVE PERCENT (5%) of the TOTAL AMOUNT OF THE BID** of the Principal above named, submitted by said Principal to the Santa Cruz Metropolitan Transit District for the work described below; for the payment of which sum in lawful money of the United States, well and truly, to be made to the Santa Cruz Metropolitan Transit District to which said bid was submitted, we bind ourselves; our heirs, executors, administrators and successors, jointly and severally, firmly by these presents. In no case shall the liability of the surety hereunder exceed the sum of

\$ _____.

THE CONDITION OF THIS OBLIGATION IS SUCH,

THAT, WHEREAS, the Principal has submitted the above-mentioned bid to the Santa Cruz Metropolitan Transit District, aforesaid, for certain construction specifically described as follows, for which bids are to be opened at the Santa Cruz Metropolitan Transit District's Administrative Office, 370 Encinal Street, Suite 100, Santa Cruz, California 95060 on **Friday, December 5, 2008 at 2:00 p.m.:**

IFB NO. 09-01, DEMOLITION OF OLD BUS WASH AREA AT 1200 RIVER STREET, SANTA CRUZ

NOW, THEREFORE, if the aforesaid Principal is awarded the contract and within the time and manner required under the specification, after the prescribed forms are presented to him for signature, enters into a written contract, in the prescribed form, in accordance with the bid, files two bonds with the District, one to guaranty faithful performance, and the other to guaranty payment for labor and materials as required by law, and required insurance certificates, then this obligation shall be null and void; otherwise, it shall be and remain in full force and virtue.

IN WITNESS WHEREOF, we have hereto set our hands and seals on this

_____ day of _____, 2008

_____ (Seal)

_____ (Seal)

_____ (Seal)

Principal

_____ (Seal)

_____ (Seal)

_____ (Seal)

Surety

NOTE: Signatures of those executing for the surety must be properly acknowledged.

END OF BIDDER'S BOND

ATTACHMENT C

PAYMENT BOND

(To be submitted prior to Signing Contract)

KNOW ALL PERSONS BY THESE PRESENTS:

That we, _____ as Principal,
and _____ organized and existing
under the laws of the State of _____ and authorized to execute bonds and undertaking
as sole surety, as Surety, are held and firmly bound unto any and all persons named in California Civil Code Section
3181 whose claim has not been paid by the Contractor, company or corporation in the aggregate total of
_____ Dollars (\$ _____)
(being 100% of the Contract amount) for the payment whereof, well and truly to be made, said Principal and Surety
bond themselves, their heirs, administrators, successors, and assigns, jointly and severally, firmly by these presents.

The condition of the foregoing obligation is such that, whereas the above bounden Principal has entered into a
Contract dated _____ 200_, with Santa Cruz Metropolitan Transit District to do the
following work, to-wit: Construct the _____ Project.

NOW, THEREFORE, if the above-bounden Principal or his subcontractors fail to pay any of the persons named in
Section 3181 of the Civil Code of the State of California, or amounts due under the Unemployment Insurance Code
with respect to work or labor performed under the Contract, or for any amounts required to be deducted, withheld,
and paid over to the Employment Development Department from the wages of employees of the Contractor and his
subcontractor pursuant to Section 13020 of the Unemployment Insurance Code of the State of California, with
respect to such work and labor, the surety will pay for the same, in the amount not exceeding the sum specified in
this bond, and also, in case suit is brought upon this bond, a reasonable attorney's fee, to be fixed by the Court.

This bond shall inure to the benefit of any person named in Section 3181 of the Civil Code of the State of California
so as to give a right of action to them or their assignees in suit brought upon this bond.

This bond is executed and filed to comply with the provisions of the act of Legislature of the State of California as
designed in Civil Code Sections 3247 to 3252, inclusive, and all amendments thereto.

And the said Surety, for value received, hereby stipulates and agrees to waive the provisions of California Civil Code
Section 2819 regarding consent to change, extension of time alteration, or addition to the terms of the Contract, or to
the work to be performed thereunder, or the Specifications accompanying the same, shall in any way affect its
obligations on this bond; and it does hereby waive notice of any such change, extension of time, alteration, or
addition to the terms of the Contract, or to the work, or to the Specifications.

IN WITNESS WHEREOF, the above bounden parties have executed this instrument under their seals this
_____ day of _____ 200_, the name and corporate seal of each corporate party being
hereto affixed and these presents duly signed by its undersigned representative, pursuant to authority of its governing
body.

ATTEST:

(Principal) Secretary

(Principal)

(SEAL)

By _____
(Signature/Title(s))

ATTACHMENT C

PERFORMANCE BOND (To be submitted Prior to Signing Contract)

KNOW ALL MEN BY THESE PRESENTS: that

(Name of Contractor)

(Address of Contractor)

a _____, hereinafter called Principal,
(Corporation, Partnership, or Individual)

and _____
(Name of Surety)

(Address of Surety)

hereinafter called Surety, are held and firmly bound

unto _____
(Name of Owner)

(Address of Owner)

Hereinafter called OWNER, in the penal sum of 100% of CONTRACT AMOUNT _____

_____ Dollars. \$(_____) in lawful money of the
United States, for the payment of which sum well and truly to be made, we bind ourselves, successors, and assigns,
jointly and severally, firmly by these presents.

THE CONDITION OF THIS OBLIGATION is such that whereas, the Principal entered into a certain contract with
the OWNER, dated the _____ day of _____, 20_____, a copy of which is hereto attached and
made a part hereof for the construction of:

NOW, THEREFORE, if the Principal shall well, truly and faithfully perform its duties, all the undertakings,
covenants, terms, conditions, and agreements of said contract during the original term thereof, and any extensions
thereof which may be granted by the OWNER, with or without notice to the Surety and during the one year guaranty
period, and if he shall satisfy all claims and demands incurred under such contract, and shall fully indemnify and
save harmless the OWNER from all costs and damages which it may suffer by reason of failure to do so, and shall
reimburse and repay the OWNER all outlay and expense which the OWNER may incur in making good any default,
then this obligation shall be void; otherwise to remain in full force and effect.

PROVIDED FURTHER, that the said surety, for value received hereby stipulates and agrees that no charge,
extension of time, alteration or addition to the terms of the contract or to WORK to be performed thereunder or the
SPECIFICATIONS accompanying the same shall in any wise affect its obligation on this BOND, and it does
whereby waive notice of any such change, extension of time, alteration or addition to the terms of the contract or to
the WORK or to the SPECIFICATIONS.

ATTACHMENT C

In the event the District, or its successors or assigns, shall be the prevailing party in action brought upon this bond, then, in addition to the penal sum hereinabove specified, we agree to pay to the said district, or its successors or assigns, a reasonable sum on account of attorney's fees in such action, which sum shall be fixed by the court.

PROVIDED FURTHER, that no final settlement between the OWNER and the CONTRACTOR shall abridge the right of any beneficiary hereunder, whose claim may be unsatisfied.

IN WITNESS WHEREOF, this instrument is executed in 4 counterparts,

Each one of which shall be deemed to be an original, this the _____ day of _____, 20_____.

ATTEST:

Principal

(Principal) Secretary

By _____ (s)

(SEAL)

(Witness as to Principal)

(Address)

(Address)

ATTEST:

(Surety) Secretary

(SEAL)

Witness as to Surety

By _____ (s)
Attorney-in-Fact

(Address)

(Address)

END OF PERFORMANCE BOND

ATTACHMENT D

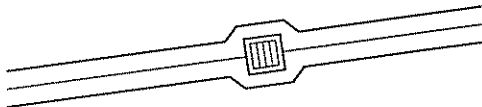

EQUIPMENT, SLABS
TO 12" BELOW

MATCH EXISTING -
DIG AWAY FROM
WHAT IS
GRADE.

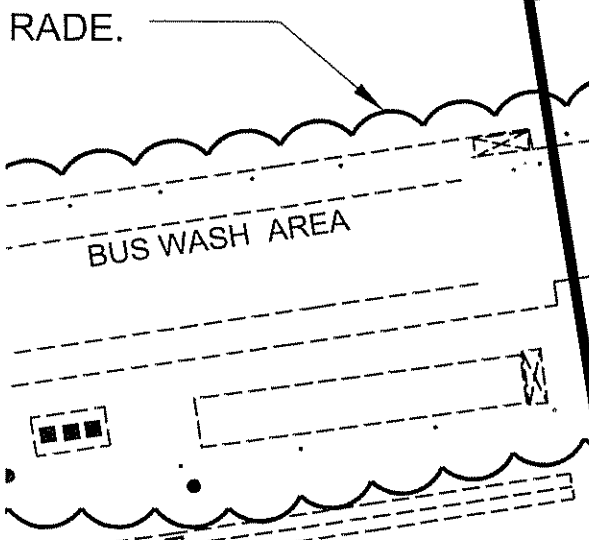

**NOT IN
CONTRACT**

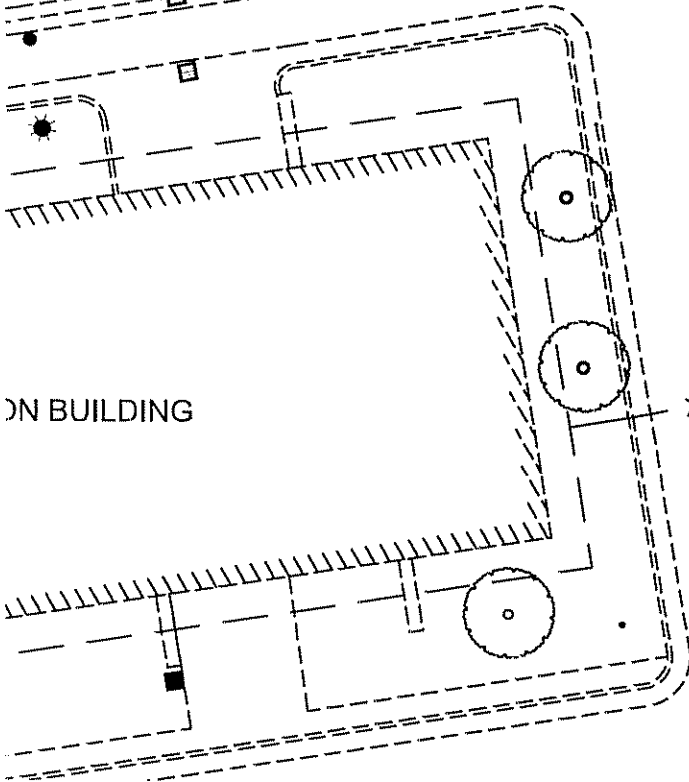

ON BUILDING

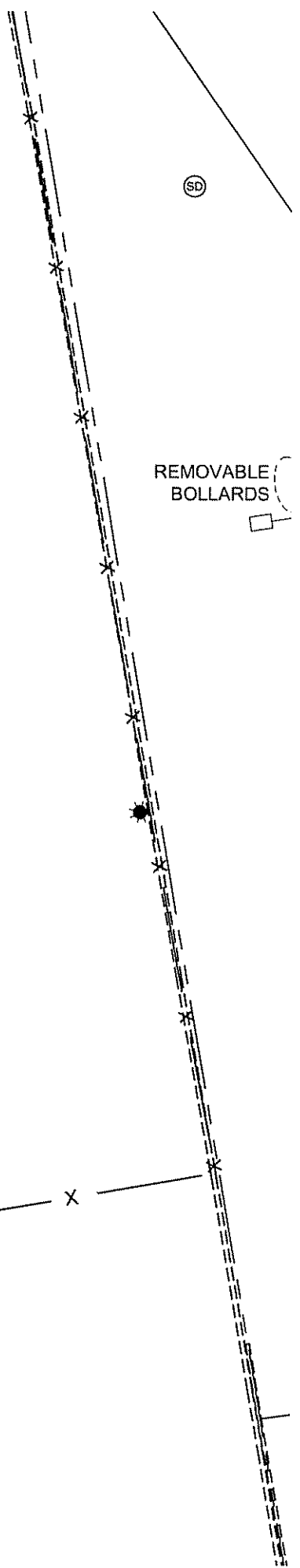

REMOVABLE
BOLLARDS

SD

SD



ADDENDUM NO. 2

Date of Issue: December 3, 2008

Invitation for Bids (IFB) No. 09-01

**SANTA CRUZ METROPOLITAN TRANSIT DISTRICT
For Demolition of the Old Bus Wash Area at 1200 River Street**

****NEW BID DUE DATE: December 12, 2008 @ 2:00 PM, PST**

Notice is hereby given that the Santa Cruz Metropolitan Transit District, Santa Cruz, State of California is providing the following clarifications, modifications, additions and / or deletions to the Invitation for Bids (IFB) No. 09-01 for Demolition of Old Bus Wash Area at 1200 River Street. This Addendum shall become a part of the original IFB as issued by the Santa Cruz Metropolitan Transit District **and the bid date and time have been changed to December 12, 2008 @ 2:00 PM, PST.**

Receipt of this Addendum No. 2 shall be acknowledged in your bid response. Any adjustment resulting from this addendum shall be included in the IFB. Where in conflict, the terms and conditions of this addendum supersede those in the Invitation for Bid.

All questions concerning this Addendum shall be referred to Lloyd Longnecker, Purchasing Agent at 370 Encinal Street, Suite 100, Santa Cruz, CA 95060, (831) 426-0199 Voice, (831) 423-2918 Fax, or email address llongnecker@scmttd.com.

This Addendum forms a part of the Contract Documents, and modifies the following as noted below:

1. ADDENDUM CONTENT:

1.1 Addendum No. 2: 4 pages

- Attachment A: The current plan holder's list.

2. CHANGES TO PREVIOUS ADDENDA:

Correction to Item 4. CHANGES TO IFB TERMS AND CONDITIONS, page 2, item 4.1.D.h. Item was left off in error from Addendum No. 1 and is included in the corrected revision as follows:

4.1 Revision to Part III, Section 01100 – Summary, Item 1.03 WORK COVERED BY CONTRACT DOCUMENTS, D, **Revise** as follows:

- D. The Work consists of a waste management plan, temporary fencing (~~which will remain beyond contract completion under a lease transfer agreement to the District~~), removal of identified hazardous materials, demolition of above and below grade construction elements, capping in place of existing utilities, and sandbagging to prevent runoff of demolition-created exposed silt.

1. The Work includes:

- a. Temporary site fencing
- b. Clearing of bus wash structure, canopy and related sheds.
- c. Recommended removal of identified hazardous materials.
- d. Preparation and execution of a waste management plan with goal to recycle/salvage 50% of the demolition volume.
- e. Demolition of above and below grade structures.
- f. ~~Level Filling of demolished footprint and foundation removal soil depressions with broken concrete to within 6" of the adjacent driving surfaces.~~
- g. Removal from site of all salvage and demolition waste.
- h. Re-pave demolition area with asphalt.**
- i. Remove and properly dispose of 12' x 42' trailer located adjacent to the bus wash area.

3. BIDDERS REQUESTS FOR CLARIFICATIONS:

3.1 For the demolition area that is to be patched back with asphalt concrete, how many inches thick is the asphalt concrete supposed to be? Demolition calls for 12" below grade and we are unclear as to how thick the required asphalt concrete needs to be.

Answer: Reference page Part III-8 Section 02740 - Flexible Pavement (2.01 Materials).

4. CHANGES TO IFB TERMS AND CONDITIONS: (NONE)

Please Note: *All other terms and conditions of the IFB dated October 24, 2008 remain unchanged.*

END OF ADDENDUM NO. 2

Lloyd Longnecker
Purchasing Agent

**ATTACHMENT A
CURRENT LIST OF PLAN HOLDERS**

**Coastwide Environmental Technologies
201 Walker Street
Watsonville CA 95076**

**Monteith Construction Inc.
P O Box 572
Felton CA 95018**

**NICA DMT INCORPORATED
Harold Mendoza
101 North Greenville Rd

Livermore CA 94551-5803**

**RANDAZZO ENTERPRISES
13550 Blackie Rd
Castroville CA 95012-3200**

**Ginochio Excavating
100 Lagunita Dr
Soquel CA 95073**

**ADH Environmental
3550 North Main Street
Soquel CA 95073**

WC Maloney

**PO Box 30326
Stockton CA 95213-0326**

**HSR INC.
530 Aldo Ave
Santa Clara CA 95054**

**HAZMAT SOLUTIONS INC
1113 1st St
Novato CA 94945-2403**

**Evan Bros. Inc.
Chris Geiss
7589 National Dr
Livermore CA 94550**

**A & S Metals
11340 Commercial Way
Castroville CA 95012**

**PAVEX CONSTR
411 Walker St
Watsonville CA 95076-4225**

MS Services

**1190 Lincoln Ave #2
San Jose CA 95125**

**Buccaneer Demolition
618 S. First Co
San Jose CA 95113**

**Olcese Construction
PO Box 5682
Incline Village NV 89450**

**PJB Demo
PO Box 1114
Freedom CA 95019**

**Carpenters Union
225 Searidge Road
Aptos CA 95003**

**PENHALL CO
696 Walsh Ave
Santa Clara CA 95050-2628**

**T.M. Sweatt
1518 Pyramid Ct
San Jose CA 95130**

**Earth Moving & Demolition, Inc.
P O Box 1540
Bryon CA 94514**

**Reber Construction
PO Box 273
Santa Cruz CA 95060**

**Roldan Construction, Inc.
4607 Enterprise Common
Fremont CA 94538**

**Bluewater Services, Inc.
2075 Williams Street
San Leandro CA 94577**

**Bayline Demolition, Inc.
P O Box 23464
San Jose CA 95153**

**Ferma Corporation
1265 Montecito Ave
Suite 200
Mountain View CA 94043-4506**

**Henningsen Construction Co., Inc.
P O Box 7477
Spreckels CA 93962**

ACS
P O Box 2465
Hollister CA 95024

Community Tree Service and Demolition
320 Industrial Road
Watsonville CA 95076

Cleveland Wrecking Company
Alicia Gaddis
628 East Edna Place
Covina CA 91723

Johnson & Company inc.
Jay Johnson
600 Calabasas Road
Watsonville CA 95076

WEBER TRACTOR SERVICE
867 2ND AVE
REDWOOD CITY, CA. 94063

Geofon, Inc.
Barbara Stevens
22632 Golden Springs Drive, Suite
Diamond Bar CA 91765

Jack Cook
PARC Services, Inc.
253 Rickenbacker Cir., #B
Livermore, Ca. 94551

T. Boyd Construction
P O Box 3783
Coeur d Alene ID 83816

Santa Cruz Builders Exchange
1248 Thompson Ave
Santa Cruz CA 95062

Builders Exchange of the
Central Coast
100 12th St bldg 2861
Marina CA 93933

Earthworks
310-A Kennedy Drive
Capitola CA 95010

Granite Construction Co
P O Box 720
Watsonville CA 95077

Mimi Zavala
McGraw Hill Construction Dodge
1333 S. Mayflower Suite 300
Monrovia CA 91016

Michael Lunan
Reed Construction Data
30 Technology Pkwy S, Ste 500
Norcross, GA 30092

Salinas Valley Builders Exchange
20 Quail Run Circle #A
Salinas, CA. 93907

Edwin Sargenti
PSC Industrial Services
Division-Demolition
P.O. Box 431
62117 Railroad Ave
San Ardo, CA 93450

Nicole Bryant
Bureau Veritas North America, Inc.
1565 MacArthur Boulevard
Costa Mesa, CA 92626

Karen Blanchard
Zaccor Companies, Inc
PO Box 590
Alameda, CA 94501

Sara Orrick, Partner
Pacific Underground Services
3881 Martha Drive
Martinez CA 94553-3026

Trinet Construction, Inc.
2560 Marin Street
San Francisco CA 95124

Sean McHugh
Jos. J. Albanese, Inc.
988 Walsh Avenue
Santa Clara CA 95050

Mark Nicholson, Inc.
P O Box 58
Hollister, CA 95024

Victor Chavez
P & C Demo and Construction
2160 California Ave, Ste B-225
Sand City CA 93955

Edwin Sargenti
PSC
P O Box 431
San Ardo CA 93450

ADDENDUM NO. 3

Date of Issue: December 10, 2008



Invitation for Bids (IFB) No. 09-01

**SANTA CRUZ METROPOLITAN TRANSIT DISTRICT
For Demolition of the Old Bus Wash Area at 1200 River Street**

****NEW BID DUE DATE: December 19, 2008 @ 2:00 PM, PST**

Notice is hereby given that the Santa Cruz Metropolitan Transit District, Santa Cruz, State of California is providing the following clarifications, modifications, additions and / or deletions to the Invitation for Bids (IFB) No. 09-01 for Demolition of Old Bus Wash Area at 1200 River Street. This Addendum shall become a part of the original IFB as issued by the Santa Cruz Metropolitan Transit District **and the bid date and time have been changed to December 19, 2008 @ 2:00 PM, PST.**

Receipt of this Addendum No. 3 shall be acknowledged in your bid response. Any adjustment resulting from this addendum shall be included in the IFB. Where in conflict, the terms and conditions of this addendum supersede those in the Invitation for Bid.

All questions concerning this Addendum shall be referred to Lloyd Longnecker, Purchasing Agent at 370 Encinal Street, Suite 100, Santa Cruz, CA 95060, (831) 426-0199 Voice, (831) 423-2918 Fax, or email address llongnecker@scmttd.com.

This Addendum forms a part of the Contract Documents, and modifies the following as noted below:

1. ADDENDUM CONTENT:

1.1 Addendum No. 3: 8 pages

- Attachment A: Drawings for AC Pavement
- Attachment B: Revised Bid Sheet
- Attachment C: The current plan holder's list.

2. CHANGES TO PREVIOUS ADDENDA: (NONE)

3. BIDDERS REQUESTS FOR CLARIFICATIONS:

3.1 For the demolition area that is to be patched back with asphalt concrete, how many inches thick is the asphalt concrete supposed to be? Demolition calls for 12" below grade and we are unclear as to how thick the required asphalt concrete needs to be.

Answer: Asphalt concrete is to be four (4) inches thick. Reference attached drawings titled Vehicular AC Pavement and AC Pavement Conform (Attachment A)

3.2 Reference page Part III-9 Section 02740 - Flexible Pavement (2.01 Materials), 1.04 Measurement & Payment states that the asphalt will be paid for as a unit price. This is a lump sum bid without any lines for unit pricing. Will you provide a revised bid form to match these payment terms? Please advise.

Answer: Please use the attached Revised Bid Sheet

3.3 Reference page Part III-11 Section 02740 - Flexible Pavement, item 3.03 Installation, D. Fog Seal. This specification requires that a fog seal be installed to all new asphalt surfaces. I am not sure this is really what you want to have done, especially knowing that the AC Patch is only temporary. Please advise.

Answer: Delete the requirements for a fog seal.

4. **CHANGES TO IFB TERMS AND CONDITIONS:** (NONE)

Please Note: *All other terms and conditions of the IFB dated October 24, 2008 remain unchanged.*

END OF ADDENDUM NO. 3

Lloyd Longnecker
Purchasing Agent

Attachment A

Date _____ Sheet Number _____

By _____ Project Number _____

Subject _____



RNI Interplan Inc
 A California Corporation
 800 Wilshire Boulevard Suite 400
 Los Angeles California 90017
 p) 213 955 9775
 f) 213 955 9885

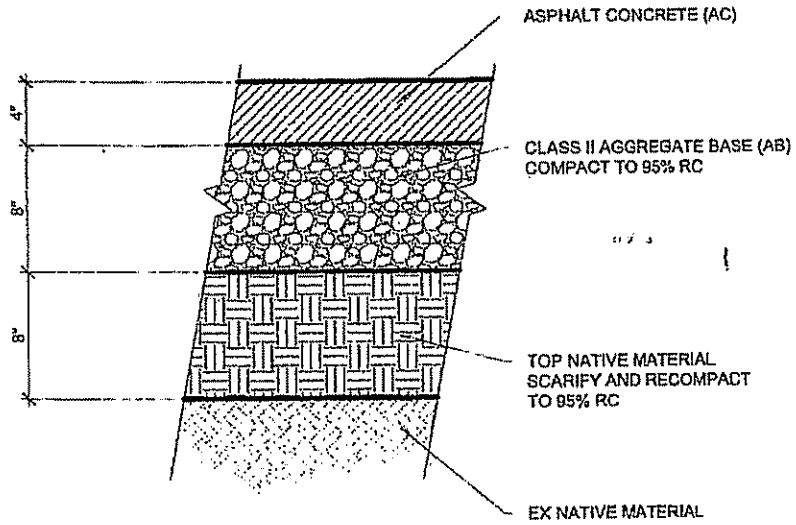

1	VEHICULAR AC PAVEMENT
1 1/2" = 1'-0"	RE:

Attachment A



Date _____ Sheet Number _____

By _____ Project Number _____

Subject _____

RNI Interplan Inc

A California Corporation

800 Wilshire Boulevard Suite 400

Los Angeles California 90017

pl 213 955-9775

fl 213 955-9885

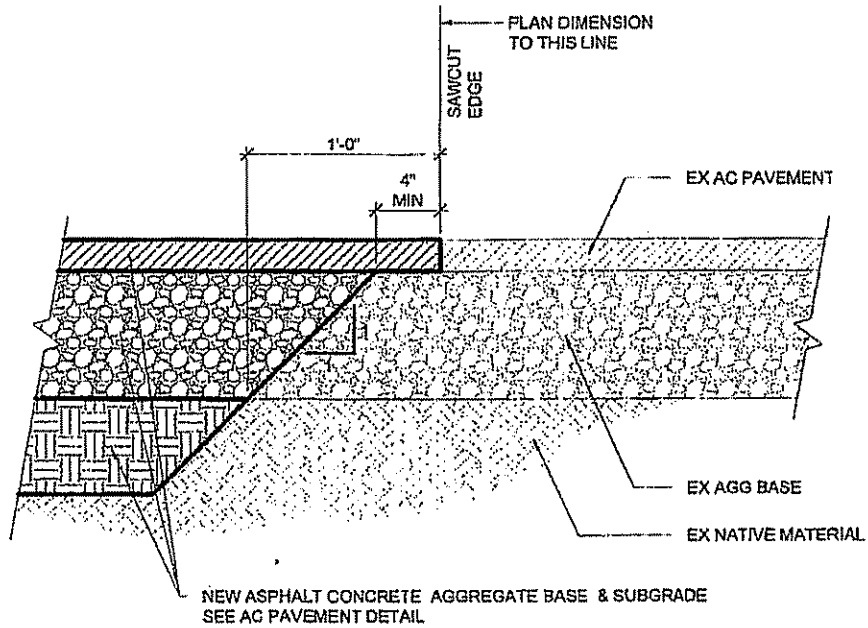

2	AC PAVEMENT CONFORM
1 1/2" = 1'-0"	RE:

ATTACHMENT B

REVISED BID FORM

The undersigned ("Bidder"), upon acceptance by the District, agrees to furnish all labor, freight, transportation, materials, equipment, services, supplies and other work in accordance with the Invitation for Bids entitled Item dated October 24, 2008 at the following prices.

Item No.	Item Description	Quantity	Total Contract Price Including All Labor, Parts, Materials, Equipment, Incidentals And Any Applicable Taxes
1	Demolition of old bus wash area located at 1200 River Street, Santa Cruz as per all specifications, instructions, and conditions of District IFB No. 09-01.	Lump Sum	\$ _____
2	Unit Price for vehicular asphalt concrete		\$ _____
3	Unit Price for asphalt concrete overlay		\$ _____

The successful bidder obligates him/herself to provide any or all of the bid items at the bid price. District reserves the right to award bid items separately or as a package. District may accept or reject the bid items at its discretion. Award of the bid will be based on totals provided for the Base Items. Options shall not be used in the determination of low bid. The Board of Directors also reserves the right to reject all bids for any reason.

Bidder has examined and is fully familiar with all terms and conditions of the Invitation for Bids and any addenda issued by the District thereto, and Bidder unconditionally submits this bid in strict accordance with said Invitation for Bids. Bidder has carefully checked all words and figures shown on this Bid Form and has carefully reviewed the accuracy of all documents, representations, manufacturer's literature, and statements submitted with this bid.

Bidder understands that this bid constitutes a firm offer to the District that cannot be withdrawn for ninety (90) calendar days from the date of bid opening. If awarded the contract, bidder agrees to deliver to the District executed copies of the final contract and required insurance certificates within ten (10) calendar days of the date of the District Notice of Award. Said Notice of Award shall be deemed duly given to Bidder upon delivery if delivered by hand, or three (3) calendar days after posting if sent by mail to Bidder's address.

Bidder understands that no partial, conditional or qualified bids shall be accepted for any bid item. Bidder further understands the right of the District Board of Directors to accept or reject any or all bids received for any reason. The District reserves the right to waive minor irregularities.

The contract, if awarded, will be to the lowest responsive, responsible bidder. Bidder understands that the "lowest responsible bidder" is the lowest bidder whose offer best responds in quality, fitness and capacity to the requirements of the Invitation for Bids. The District reserves the right to award to other than the lowest bidder if the District finds that the lowest bidder is not responsible.

Bidder acknowledges receipt of the following addenda to the Invitation for Bids. All cost adjustments or other requirements resulting from said addenda have been taken into consideration by the bidder and included in the bid.

Addenda No.'s 1, 2, and 3

Bidder has submitted the following documents with the bid:

1. Exceptions, if any, taken to the specifications or other sections of the IFB. (Warning: Substantive exceptions will be cause for bid rejection.)
2. Copy of any standard warranties in accordance with the Specifications.
3. Bidder's Security
4. Fully executed copy of the "Lobbying Certification" listed as Page 1-4 of the Bid, if applicable
5. Fully executed copy of the "Buy America Provision Certification" listed as Page 1-5 of the Bid, if applicable.

Bidder understands that bids shall be placed in a sealed envelope marked as indicated below and delivered to the Santa Cruz Metropolitan Transit District, 370 Encinal Street, Suite 100, Santa Cruz, California, 95060 prior to the time of bid opening. Bids postmarked before bid opening but delivered afterward shall be rejected.

IFB No. 09-01

"Demolition of Old Bus Wash Area"
Bid Opening 2:00 p.m., December 19, 2008

**ATTACHMENT C
CURRENT PLAN HOLDER
LIST**

NICA DMT INCORPORATED
Harold Mendoza
101 North Greenville Rd

Livermore CA 94551-5803

ADH Environmental
3550 North Main Street
Soquel CA 95073

Hazmat Solutions Inc
1113 1st St
Novato CA 94945-2403

Pavex Construction
411 Walker St
Watsonville CA 95076-4225

Jeff Manely
Universal Structures
9920 Equestrian Place
Salinas CA 93907

Trinet Construction, Inc.
2560 Marin Street
San Francisco CA 95124

Olcese Construction
PO Box 5682
Incline Village NV 89450

Penhall CO
696 Walsh Ave
Santa Clara CA 95050-2628

**Coastwide Environmental
Technologies**
201 Walker Street
Watsonville CA 95076

RANDAZZO ENTERPRISES
13550 Blackie Rd
Castroville CA 95012-3200

WC Maloney
PO Box 30326
Stockton CA 95213-0326

Jack Cook
PARC Services, Inc.
253 Rickenbacker Cir., #B
Livermore, Ca. 94551

T. Boyd Construction
P O Box 3783
Coeur d Alene ID 83816

Evan Bros. Inc.
Chris Geiss
7589 National Dr
Livermore CA 94550

MS Services
1190 Lincoln Ave #2
San Jose CA 95125

PJB Demo
PO Box 1114
Freedom CA 95019

T.M. Sweatt
1518 Pyramid Ct
San Jose CA 95130

Monteith Construction Inc.
P O Box 572
Felton CA 95018

Ginochio Excavating
100 Lagunita Dr
Soquel CA 95073

HSR INC.
530 Aldo Ave
Santa Clara CA 95054

A & S Metals
11340 Commercial Way
Castroville CA 95012

Buccaneer Demolition
618 S. First Co
San Jose CA 95113

Carpenters Union
225 Searidge Road
Aptos CA 95003

Earth Moving & Demolition, I
P O Box 1540
Bryon CA 94514

Bluewater Services, Inc.
2075 Williams Street
San Leandro CA 94577

Henningsen Construction Co.,
P O Box 7477
Spreckels CA 93962

Reber Construction
PO Box 273
Santa Cruz CA 95060

Bayline Demolition, Inc.
P O Box 23464
San Jose CA 95153

ACS
P O Box 2465
Hollister CA 95024

**Builders Exchange of the
Central Coast**
100 12th St bldg 2861
Marina CA 93933

Mimi Zavala
McGraw Hill Construction Dodge
1333 S. Mayflower Suite 300
Monrovia CA 91016

Edwin Sargenti
PSC Industrial Services
Division-Demolition
P.O. Box 431
62117 Railroad Ave

Sara Orrick, Partner
Pacific Underground Services
3881 Martha Drive
Martinez CA 94553-3026

Mark Nicholson, Inc.
P O Box 58
Hollister, CA 95024

Machado Brothers, Inc.
1005 Spring Hill Road
Petaluma, Ca 94952

Roldan Construction, Inc.
4607 Enterprise Common
Fremont CA 94538

Ferma Corporation
1265 Montecito Ave
Suite 200
Mountain View CA 94043-4506

**Community Tree Service and
Demolition**
320 Industrial Road
Watsonville CA 95076

Earthworks
310-A Kennedy Drive
Capitola CA 95010

Michael Lunan
Reed Construction Data
30 Technology Pkwy S, Ste 500
Norcross, GA 30092

Nicole Bryant
Bureau Veritas North America,
Inc.
1565 MacArthur Boulevard
Costa Mesa, CA 92626

Johnson & Company inc.
Jay Johnson
600 Calabasas Road
Watsonville CA 95076

Victor Chavez
P & C Demo and Construction
2160 California Ave, Ste B-225
Sand City CA 93955

Bellicitti & Pellicciotti
Construction Company, Inc.
P.O. Box 606
Santa Clara, CA 95052-0606

Cleveland Wrecking Company
Alicia Gaddis
628 East Edna Place
Covina CA 91723

Geofon, Inc.
Barbara Stevens
22632 Golden Springs Drive, Suite 27
Diamond Bar CA 91765

Santa Cruz Builders Exchange
1248 Thompson Ave
Santa Cruz CA 95062

Granite Construction Co
P O Box 720
Watsonville CA 95077

Salinas Valley Builders Exchar
20 Quail Run Circle #A
Salinas, CA. 93907

Karen Blanchard
Zaccor Companies, Inc
PO Box 590
Alameda, CA 94501

Sean McHugh
Jos. J. Albanese, Inc.
988 Walsh Avenue
Santa Clara CA 95050

Edwin Sargenti
PSC
P O Box 431
San Ardo CA 93450
esargenti@PSCNow.com

Weber Tractor Service
867 2nd Ave
Redwood City, CA. 94063

EXHIBIT - B

REVISED BID FORM

The undersigned ("Bidder"), upon acceptance by the District, agrees to furnish all labor, freight, transportation, materials, equipment, services, supplies and other work in accordance with the Invitation for Bids entitled Item dated October 24, 2008 at the following prices

Item No.	Item Description	Quantity	Total Contract Price Including All Labor, Parts, Materials, Equipment, Incidentals And Any Applicable Taxes
1	Demolition of old bus wash area located at 1200 River Street, Santa Cruz as per all specifications, instructions, and conditions of District IFB No 09-01	Lump Sum	\$ <u>28,850.00</u>
2	Unit Price for vehicular asphalt concrete	SF	\$ <u>4.25</u>
3	Unit Price for asphalt concrete overlay	SF	\$ <u>2.50</u>

The successful bidder obligates him/herself to provide any or all of the bid items at the bid price. District reserves the right to award bid items separately or as a package. District may accept or reject the bid items at its discretion. Award of the bid will be based on totals provided for the Base Items. Options shall not be used in the determination of low bid. The Board of Directors also reserves the right to reject all bids for any reason.

Bidder has examined and is fully familiar with all terms and conditions of the Invitation for Bids and any addenda issued by the District thereto, and Bidder unconditionally submits this bid in strict accordance with said Invitation for Bids. Bidder has carefully checked all words and figures shown on this Bid Form and has carefully reviewed the accuracy of all documents, representations, manufacturer's literature, and statements submitted with this bid.

Bidder understands that this bid constitutes a firm offer to the District that cannot be withdrawn for ninety (90) calendar days from the date of bid opening. If awarded the contract, bidder agrees to deliver to the District executed copies of the final contract and required insurance certificates within ten (10) calendar days of the date of the District Notice of Award. Said Notice of Award shall be deemed duly given to Bidder upon delivery if delivered by hand, or three (3) calendar days after posting if sent by mail to Bidder's address.

Bidder understands that no partial, conditional or qualified bids shall be accepted for any bid item. Bidder further understands the right of the District Board of Directors to accept or reject any or all bids received for any reason. The District reserves the right to waive minor irregularities.

The contract, if awarded, will be to the lowest responsive, responsible bidder. Bidder understands that the "lowest responsible bidder" is the lowest bidder whose offer best responds in quality, fitness and capacity to the requirements of the Invitation for Bids. The District reserves the right to award to other than the lowest bidder if the District finds that the lowest bidder is not responsible.

Bidder acknowledges receipt of the following addenda to the Invitation for Bids. All cost adjustments or other requirements resulting from said addenda have been taken into consideration by the bidder and included in the bid.

Addenda No.'s 1, 2, and 3

Bidder has submitted the following documents with the bid:

- 1 Exceptions, if any, taken to the specifications or other sections of the IFB (Warning: Substantive exceptions will be cause for bid rejection)
- 2 Copy of any standard warranties in accordance with the Specifications
- 3 Bidder's Security
- 4 Fully executed copy of the "Lobbying Certification" listed as Page 1-4 of the Bid, if applicable
- 5 Fully executed copy of the "Buy America Provision Certification" listed as Page 1-5 of the Bid, if applicable

Bidder understands that bids shall be placed in a sealed envelope marked as indicated below and delivered to the Santa Cruz Metropolitan Transit District, 370 Encinal Street, Suite 100, Santa Cruz, California, 95060 prior to the time of bid opening. Bids postmarked before bid opening but delivered afterward shall be rejected.

IFB No. 09-01

**"Demolition of Old Bus Wash Area"
Bid Opening 2:00 p.m., December 19, 2008**

Bidder has full power and authority to enter into and perform the work described in the Invitation for Bids on behalf of the company noted below.

Jos. J. Albanese, Inc.

Company Name

Indicate:

Sole Proprietorship Partnership Corporation

Joint Venture with _____

986 Walsh Avenue

Street Address

Santa Clara, CA 95050

City, State, Zip Code



Signature of authorized company official

John L. Albanese, President

Typewritten name of above and title

Chris Albanese, Estimator / Project Manager, calbanese@jjalbanese.com or

Name, title, and email address of person to whom correspondence should be directed
Diane Schmidt Assistant PM dschmidt@jjalbanese.com

408-727-5700

408-727-0366

Telephone Number

FAX Number

12/18/08

94-2247579

Date

Federal Tax ID No.

The Santa Cruz Metropolitan Transit District is a special purpose District and is a subdivision of the State of California.

**CERTIFICATION OF PROPOSED CONTRACTOR REGARDING DEBARMENT,
SUSPENSION AND OTHER INELIGIBILITY AND VOLUNTARY EXCLUSION**

(Contractor) Jos. J. Albanese, Inc. certifies to the best of its knowledge and belief, that it and its principals:

Are not presently debarred, suspended, proposed for debarment, declared ineligible or voluntarily excluded from covered transactions by any Federal department or agency;

Have not within a three year period preceding this bid been convicted of or had a civil judgment rendered against them for commission of fraud or a criminal offense in connection with obtaining, attempting to obtain or performing a public (Federal, State, or local) transaction or contract under a public transaction; violation of Federal or State antitrust statutes or commission of embezzlement, theft, forgery, bribery, falsification or destruction of records, making false statements or receiving stolen property;

Are not presently indicted for or otherwise criminally or civilly charged by a governmental entity (Federal, State or local) with commission of any of the offenses enumerated in paragraph (2) of this certification; and

Have not within a three year period preceding this bid had one or more public transactions (Federal, State or local) terminated for cause or default.

If the Proposed Subcontractor is unable to certify to any of the statements in this certification, it shall attach an explanation to this certification.

(Contractor) Jos. J. Albanese, Inc., CERTIFIES OR AFFIRMS THE TRUTHFULNESS AND ACCURACY OF THE CONTENTS OF THE STATEMENTS SUBMITTED ON OR WITH THIS CERTIFICATION AND UNDERSTANDS THAT THE PROVISIONS OF 31 U.S.C. SECTIONS 3801 ET. SEQ. ARE APPLICABLE THERETO.

Signature and Title of Authorized Official
John L. Albanese, President

LOBBYING CERTIFICATION
(Only for Contracts above \$100,000)

Lobbying Certification for Contracts Grants, Loans and Cooperative Agreements (Pursuant to 49 CFR Part 20, Appendix A)

The undersigned certifies, to the best of his or her knowledge and belief, that:

- (1) No Federal appropriated funds have been paid or will be paid, by or on behalf of the undersigned, to any person for influencing or attempting to influence an officer or employee of an agency, a Member of Congress, an officer or employee of Congress, or an employee of a Member of Congress in connection with the awarding of any Federal Contract, the making of any Federal grant, the making of any Federal loan, the entering into of any cooperative agreement, and the extension, continuation, renewal, amendment, or modification of any Federal Contract, grant, loan, or cooperative agreement.
- (2) If any funds other than Federal appropriated funds have been paid or will be paid to any person for making lobbying contacts to an officer or employee of any agency, a Member of Congress, an officer or employee of Congress, or an employee of a Member of Congress in connection with this Federal Contract, grant, loan, or cooperative agreement, the undersigned shall complete and submit Standard Form--LLL, "Disclosure Form to Report Lobbying," in accordance with its instructions and as amended by "Government wide Guidance for New Restrictions on Lobbying," 61 Fed. Reg. 1413 (1/19/96).
- (3) The undersigned shall require that the language of this certification be included in the award documents for all sub awards at all tiers (including subcontracts, sub grants, and Contracts under grants, loans, and cooperative agreements) and that all sub recipients shall certify and disclose accordingly.

This certification is a material representation of fact upon which reliance was placed when this transaction was made or entered into. Submission of this certification is a prerequisite for making or entering into this transaction imposed by 31 U.S.C. § 1352 (as amended by the Lobbying Disclosure Act of 1995). Any person who fails to file the required certification shall be subject to a civil penalty of not less than \$10,000 and not more than \$100,000 for each such failure.

The Bidder/Offeror certifies or affirms the truthfulness and accuracy of each statement of its certification and disclosure, if any. In addition, the Bidder/Offeror understands and agrees that the provisions of 31 U.S.C. A 3801, et. seq. apply to this certification and disclosure, if any.

Firm Name Jos. J. Albanese, Inc.

Signature of Authorized Official 

Name and Title of Authorized Official John L. Albanese, President

Date 12/1/08

BIDDER DBE INFORMATION

BIDDER'S NAME Jos. J. Albanese, Inc.
 DBE GOAL FROM CONTRACT 3% %
 FED. NO. _____
 COUNTY Santa Cruz
 AGENCY Santa Cruz Metro
 CONTRACT NO. 09-01

BIDDER'S ADDRESS 986 Walsh Road
Santa Clara, CA 95050
 BID AMOUNT \$ \$ 28,850.00
 BID OPENING DATE 12/19/08
 DATE OF DBE CERTIFICATION NA
 SOURCE ** Caltrans Website

http://www.dot.ca.gov/hq/bep/find_certified.htm

This information must be submitted during the initial negotiations with the District. By submitting a proposal, offeror certifies that he/she is in compliance with the District's policy. Failure to submit the required DBE information by the time specified will be grounds for finding the bid or proposal non-responsive.

CONTRACT ITEM NO.	ITEM OF WORK AND DESCRIPTION OF WORK OR SERVICES TO BE SUBCONTRACTED OR MATERIALS TO BE PROVIDED *	CERTIFICATION FILE NUMBER	NAME OF DBE	DOLLAR AMOUNT DBE ***	PERCENT DBE
1	Trucking	1993	San Jose Transport	\$ 1,520.00	5%
TOTAL CLAIMED DBE PARTICIPATION				\$ <u>1,520.00</u>	<u>5</u> %

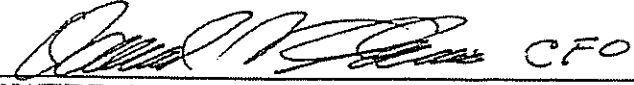
 SIGNATURE OF BIDDER

12/19/08
 DATE

AREA CODE/TELEPHONE 408-727-5700

(Detach from proposal if DBE information is not submitted with bid.)

* If 100% of item is not to be performed or furnished by DBE, describe exact portion, including plan location of work to be performed, of item to be performed or furnished by DBE.
 ** DBE's must be certified on the date bids are opened.
 *** Credit for a DBE supplier who is not a manufacturer is limited to 60% of the amount paid to the supplier.

NOTE: Disadvantaged business must renew their certification annually by submitting certification questionnaires in advance of expiration of current certification. Those not on a current list cannot be considered as certified.

ATTACHMENT C

BIDDER'S BOND

(To be submitted with Bid)

KNOW ALL PERSONS BY THESE PRESENT:

THAT WE **JOSEPH J. ALBANESE, INC.**
as PRINCIPAL, and
TRAVELERS CASUALTY AND SURETY COMPANY OF AMERICA

as SURETY, are held and firmly bound unto the Santa Cruz Metropolitan Transit District in the penal sum of **FIVE PERCENT (5%)** of the **TOTAL AMOUNT OF THE BID** of the Principal above named, submitted by said Principal to the Santa Cruz Metropolitan Transit District for the work described below; for the payment of which sum in lawful money of the United States, well and truly, to be made to the Santa Cruz Metropolitan Transit District to which said bid was submitted, we bind ourselves; our heirs, executors, administrators and successors, jointly and severally, firmly by these presents. In no case shall the liability of the surety hereunder exceed the sum of

\$ 5% OF AMOUNT BID

THE CONDITION OF THIS OBLIGATION IS SUCH,

THAT, WHEREAS, the Principal has submitted the above-mentioned bid to the Santa Cruz Metropolitan Transit District, aforesaid, for certain construction specifically described as follows, for which bids are to be opened at the Santa Cruz Metropolitan Transit District's Administrative Office, 370 Encinal Street, Suite 100, Santa Cruz, California 95060 on Friday, December 5, 2008 at 2:00 p.m.:

IFB NO. 09-01, DEMOLITION OF OLD BUS WASH AREA AT 1200 RIVER STREET, SANTA CRUZ

NOW, THEREFORE, if the aforesaid Principal is awarded the contract and within the time and manner required under the specification, after the prescribed forms are presented to him for signature, enters into a written contract, in the prescribed form, in accordance with the bid, files two bonds with the District, one to guaranty faithful performance, and the other to guaranty payment for labor and materials as required by law, and required insurance certificates, then this obligation shall be null and void; otherwise, it shall be and remain in full force and virtue.

IN WITNESS WHEREOF, we have hereto set our hands and seals on this

1ST day of DECEMBER, 2008

JOSEPH J. ALBANESE, INC. (Seal)

By:  (Seal)

Kevin J. Albanese, VP / COO (Seal)

Principal
TRAVELERS CASUALTY AND SURETY
COMPANY OF AMERICA (Seal)

By:  (Seal)

ANNA SWEETEN, ATTORNEY-IN-FACT (Seal)

Surety

NOTE: Signatures of those executing for the surety must be properly acknowledged.
END OF BIDDER'S BOND



POWER OF ATTORNEY

Farmington Casualty Company
Fidelity and Guaranty Insurance Company
Fidelity and Guaranty Insurance Underwriters, Inc.
Seaboard Surety Company
St. Paul Fire and Marine Insurance Company

St. Paul Guardian Insurance Company
St. Paul Mercury Insurance Company
Travelers Casualty and Surety Company
Travelers Casualty and Surety Company of America
United States Fidelity and Guaranty Company

Attorney-In Fact No. 220072

Certificate No. 002429922

KNOW ALL MEN BY THESE PRESENTS: That Seaboard Surety Company is a corporation duly organized under the laws of the State of New York. that St Paul Fire and Marine Insurance Company, St Paul Guardian Insurance Company and St Paul Mercury Insurance Company are corporations duly organized under the laws of the State of Minnesota, that Farmington Casualty Company, Travelers Casualty and Surety Company, and Travelers Casualty and Surety Company of America are corporations duly organized under the laws of the State of Connecticut, that United States Fidelity and Guaranty Company is a corporation duly organized under the laws of the State of Maryland. that Fidelity and Guaranty Insurance Company is a corporation duly organized under the laws of the State of Iowa. and that Fidelity and Guaranty Insurance Underwriters, Inc is a corporation duly organized under the laws of the State of Wisconsin (herein collectively called the "Companies"), and that the Companies do hereby make, constitute and appoint

Richard S. Svec, Anna Sweeten, Linda K. LaMarr, and Michael J. Heffernan

of the City of San Jose, State of California, their true and lawful Attorney(s)-in-Fact, each in their separate capacity if more than one is named above, to sign, execute, seal and acknowledge any and all bonds, recognizances, conditional undertakings and other writings obligatory in the nature thereof on behalf of the Companies in their business of guaranteeing the fidelity of persons, guaranteeing the performance of contracts and executing or guaranteeing bonds and undertakings required or permitted in any actions or proceedings allowed by law

IN WITNESS WHEREOF, the Companies have caused this instrument to be signed and their corporate seals to be hereto affixed, this 10th day of June, 2008

Farmington Casualty Company
Fidelity and Guaranty Insurance Company
Fidelity and Guaranty Insurance Underwriters, Inc.
Seaboard Surety Company
St. Paul Fire and Marine Insurance Company

St. Paul Guardian Insurance Company
St. Paul Mercury Insurance Company
Travelers Casualty and Surety Company
Travelers Casualty and Surety Company of America
United States Fidelity and Guaranty Company



State of Connecticut
City of Hartford ss

By: [Signature]
George W. Thompson, Senior Vice President

On this the 10th day of June, 2008, before me personally appeared George W. Thompson, who acknowledged himself to be the Senior Vice President of Farmington Casualty Company, Fidelity and Guaranty Insurance Company, Fidelity and Guaranty Insurance Underwriters, Inc., Seaboard Surety Company, St. Paul Fire and Marine Insurance Company, St. Paul Guardian Insurance Company, St. Paul Mercury Insurance Company, Travelers Casualty and Surety Company, Travelers Casualty and Surety Company of America, and United States Fidelity and Guaranty Company, and that he, as such, being authorized so to do, executed the foregoing instrument for the purposes therein contained by signing on behalf of the corporations by himself as a duly authorized officer

In Witness Whereof, I hereunto set my hand and official seal
My Commission expires the 30th day of June, 2011



[Signature]
Marie C. Tetreault, Notary Public

CALIFORNIA ALL-PURPOSE ACKNOWLEDGMENT

State of California

County of Santa Clara

On December 1, 2008 before me, Linda K. LaMarr, Notary Public.

personally appeared Anna Sweeten

who proved to me on the basis of satisfactory evidence to be the person whose name is subscribed to the within instrument and acknowledged to me that she executed the same in her authorized capacity, and that by her signature on the instrument the person, or the entity upon behalf of which the person acted, executed the instrument.

I certify under PENALTY OF PERJURY under the laws of the State of California that the foregoing paragraph is true and correct.

WITNESS my hand and official seal.

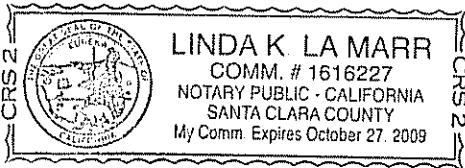

Linda K. LaMarr

PLACE NOTARY SEAL ABOVE

SIGNATURE OF NOTARY PUBLIC

OPTIONAL

Though the data below is not required by law, it may prove valuable to persons relying on the document and could prevent fraudulent removal and reattachment of this form to another document

DESCRIPTION OF ATTACHED DOCUMENT

Title of Type of Document: _____

Document Date: _____ Number of Pages: _____

Signer(s) Other Than Named Above: _____

CAPACITY(IES) CLAIMED BY SIGNER(S)

SIGNER'S NAME: _____

- INDIVIDUAL
- CORPORATE OFFICER

TITLE(S) _____

- PARTNER(S) LIMITED GENERAL
- ATTORNEY-IN-FACT
- TRUSTEE(S)
- GUARDIAN/CONSERVATOR
- OTHER : _____

SIGNER IS REPRESENTING _____

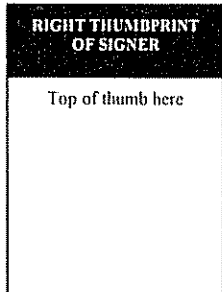

SIGNER'S NAME: _____

- INDIVIDUAL
- CORPORATE OFFICER

TITLE(S) _____

- PARTNER(S) LIMITED GENERAL
- ATTORNEY-IN-FACT
- TRUSTEE(S)
- GUARDIAN/CONSERVATOR
- OTHER : _____

SIGNER IS REPRESENTING _____

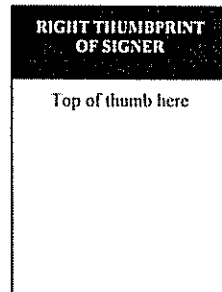

CALIFORNIA ALL-PURPOSE ACKNOWLEDGMENT

State of California

County of Santa Clara }

On 12/4/08 before me, Christine Musitano, Notary Public
Date Here Insert Name and Title of the Officer

personally appeared Kevin J. Albanese
Name(s) of Signer(s)

who proved to me on the basis of satisfactory evidence to be the person(s) whose name(s) is/are subscribed to the within instrument and acknowledged to me that he/she/they executed the same in his/her/their authorized capacity(ies), and that by his/her/their signature(s) on the instrument the person(s), or the entity upon behalf of which the person(s) acted, executed the instrument.

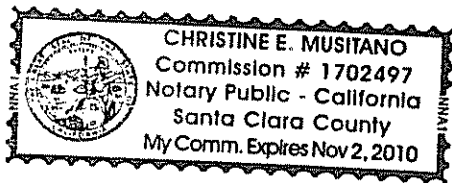

I certify under PENALTY OF PERJURY under the laws of the State of California that the foregoing paragraph is true and correct.

WITNESS my hand and official seal.

Signature Christine Musitano
Signature of Notary Public

Place Notary Seal Above

OPTIONAL

Though the information below is not required by law, it may prove valuable to persons relying on the document and could prevent fraudulent removal and reattachment of this form to another document

Description of Attached Document

Title or Type of Document: Demo of Old Bus Wash - Bid Bond

Document Date: _____ Number of Pages: _____

Signer(s) Other Than Named Above: _____

Capacity(ies) Claimed by Signer(s)

Signer's Name: Kevin J. Albanese

- Individual
- Corporate Officer — Title(s): vplcoo
- Partner — Limited General
- Attorney in Fact
- Trustee
- Guardian or Conservator
- Other: _____

Signer Is Representing: _____

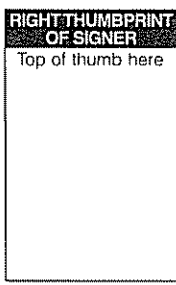

Signer's Name: _____

- Individual
- Corporate Officer — Title(s): _____
- Partner — Limited General
- Attorney in Fact
- Trustee
- Guardian or Conservator
- Other: _____

Signer Is Representing: _____

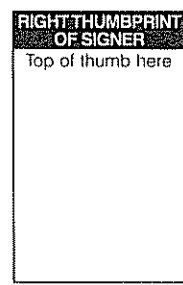

SANTA CRUZ METROPOLITAN TRANSIT DISTRICT

STAFF REPORT

DATE: January 9, 2009

TO: Board of Directors

FROM: Margaret Gallagher, District Counsel

SUBJECT: CONSIDERATION OF AUTHORIZING THE GENERAL MANAGER TO EXECUTE A TWO-YEAR IRREVOCABLE LICENSE AGREEMENT IN FAVOR OF SANTA CRUZ METRO WITH ROBERT MARIN AND CELESTE DE SCHULTHESS, TRUSTEES, FOR PLACEMENT OF A BUS STOP SHELTER ON THE FELTON FAIRE SHOPPING CENTER PROPERTY AND USAGE OF THE BUS STOP

ACTION REQUESTED AT THE JANUARY 9TH MEETING

I. RECOMMENDED ACTION

Authorize the General Manager to execute a Two-Year Irrevocable License Agreement in Favor of Santa Cruz METRO with Robert Marin and Celeste De Schulthess, Trustees, for Placement of a Bus Stop Shelter and Usage by METRO Passengers on the Felton Faire Shopping Center Property under the terms and conditions set forth in Attachment A

II. SUMMARY OF ISSUES

- There is a need for Santa Cruz METRO to maintain bus stop passenger access to the Felton Faire Shopping Center and for the erection and maintenance of a bus shelter for the bus stop located on the property.
- In 2004, the bus shelter located at the bus stop in the shopping center was demolished when a transit bus operator accidentally hit the shelter while maneuvering the bus into the stop.
- On December 19, 2008, the Board of Directors approved execution of a License and Indemnity Agreement but after the meeting Robert Marin had additional language that he wanted added to the agreement.

III. DISCUSSION

Santa Cruz METRO has an existing bus stop located at the Felton Faire Shopping Center on Graham Hill Road in Felton. In 2004, the bus shelter was demolished by a transit bus operator who accidentally hit the shelter while trying to maneuver into the bus stop. Since that time, no bus shelter exists at the stop. For the last few months METRO staff has negotiated with Mr. Marin for the right to construct a bus shelter on the property for the safety and protection of METRO passengers.

The Board of Directors approved a license agreement in December but subsequent to the meeting Mr. Marin add additional changes he wanted to make to the agreement. METRO staff made efforts to work with Mr. Marin in order to have the ability to place the shelter on the property pending the final language approval but these negotiations were unsuccessful.

The substantive change to the agreement will allow Mr. Marin to revoke the agreement if METRO violates the terms of the Addendum to the Agreement, which prohibits METRO from objecting to Mr. Marin's request of the County of Santa Cruz for a permit to enhance the Felton Faire Shopping Center.

IV. FINANCIAL CONSIDERATIONS

\$5,000 annual payments will be made for the use of the Felton Faire Shopping Center by METRO.

V. ATTACHMENTS

Attachment A: Proposed License and Indemnity Agreement

LICENSE AND INDEMNITY AGREEMENT

This LICENSE AND INDEMNITY AGREEMENT (hereinafter "Agreement") is entered into on this ~~19th~~^{9th} day of ~~December 2008~~^{January 2009} by and between Robert Marin and Celeste De Schulthess Marin, Trustees, (hereinafter collectively referred to as "Licensor") and Santa Cruz Metropolitan Transit District (hereinafter "Licensee"). Licensor and Licensee are referred to individually herein as a "Party" and collectively as the "Parties."

RECITALS:

1. Licensor is the owner of certain real property located at 6267 Mt. Hermon Road, Felton, in the County of Santa Cruz, California, APN, 071-331-02, commonly referred to as Felton Faire Shopping Center, (hereinafter, "Property");
2. Licensee desires to enter Licensor's Property in order to construct, operate and maintain a bus stop and bus shelter with one bollard from direction of approaching bus and one bollard behind the shelter at the top of a parking space (Attachment A1 through A5), which will be constructed on the Property as set forth in Attachment B1 and B2.
3. Licensor is willing for Licensee to enter and use Licensor's Property for this purpose, subject to the following terms and conditions.

NOW, THEREFORE, in consideration of the foregoing and of the mutual promises, covenants, conditions and agreements hereinafter set forth, and for other good and valuable consideration, the receipt and sufficiency of which are hereby acknowledged, the Parties hereby agree as follows:

1. **Grant of 2-Year Irrevocable License to Licensee.** Licensor hereby grants Licensee (and its respective officers, managers, employees, contractors and other authorized agents acting under Licensee's authority and within the scope of its consent) a 2-year irrevocable License to enter and use the Property for purposes of constructing, operating and maintaining certain bus stop improvements, which include a 6' x 12' bus shelter, one 6" x 36" bollard from direction of approaching bus and one 6" x 36" bollard in back of the shelter at the top of a parking space (hereinafter the "Project"). A map of the Property designating the location of the Project is attached hereto as Attachment B2 and incorporated herein by reference. Licensee's right of entry and utilization shall be confined to the designated bus stop location and access thereto, which is shown in Attachment B1 and B2. Licensor further grants permission to Licensee to operate and maintain this bus stop for the exclusive purpose of boarding and de-boarding Santa Cruz Metropolitan Transit bus passengers. Licensor further grants permission to

Licensee to allow its passengers to enter onto the Property in order to access the bus stop and to wait at the bus stop shelter for a bus.

2. **Term and Termination.** It is understood that this License Agreement shall remain in full force and effect for a period of two (2) years after the commencement date noted below. Thereafter, the License Agreement may be revoked by Licensor upon thirty (30) days written notice to Licensee. It is further agreed that if at any time during the initial two (2) year term or thereafter, (a) said bus stop improvements fall into disrepair, as determined by Licensor in its sole reasonable judgment and after Licensee has the opportunity to make and fails within thirty (30) days to make any necessary repairs, (b) Licensee ceases to operate regularly scheduled bus services to said location, ~~or~~ (c) non-payment of the annual fee, and Licensee has had the opportunity after notice of non-payment to make the payment but fails within ten (10) to make the payment, Licensor, upon thirty (30) days written notice, shall be entitled to revoke this License, or (d) if Licensee fails to comply with the Addendum to this Agreement, Licensor may revoke this Agreement, upon thirty (30) days written notice to Licensee. Licensee shall have the right to cancel the Agreement without further obligation by providing Licensor with thirty (30) days written notice. In the event this Agreement is revoked or cancelled in accordance with the preceding provisions, Licensee shall remove the constructed bus stop improvements at its own expense and restore that specific area to its preexisting condition (except the footing penetrations to the asphalt from the bus shelter that pre-dates this Agreement shall be repaired and not be considered a pre-existing condition) to Licensor's reasonable satisfaction, including **but not limited to** repairing the asphalt within the footprint of the previously existing bus shelter, within sixty (60) days, upon written request of Licensor. In no event shall Licensee be responsible to repave the parking lot asphalt in which the bus travels to and from the bus shelter area.
3. **Specifications.** Licensee has provided Licensor with copies of the plans and specifications ("Plans") for the Project (included on the map attached hereto as (Attachment A1 through A5), which Licensor has reviewed and approved. Licensee agrees to complete the Project in conformance with these Plans, except as the same may be required to be modified by the County of Santa Cruz or any other governmental agency. Any material modification of, or deviation from the Plans shall be conditioned on Licensor's prior written notification and consent.
4. **Permits.** Licensee shall, at its sole cost and expense, obtain all necessary governmental permits and approvals required to undertake work on the Project. Licensee shall comply with all laws, codes, rules, regulations, and permits applicable to the use of the Property for the purposes herein contemplated.
5. **Non-Interference with Tenant's Operations.** Licensee shall perform all work associated with the Project in such a way that it does not unreasonably disrupt

Licensors' operations and shall minimize any inconvenience to Licensors' tenants, customers or invitees. Licensee shall also take every commercially reasonable precaution to prevent and avoid damage to the Property, its improvements, and any and all persons or property located thereon, arising from completing the Project.

6. **Repair.** Licensee shall, at its sole cost and expense, at all time maintain the bus shelter in good working order and promptly repair any damage that the bus shelter may sustain for any reason. Licensee shall pay to Licensor \$5,000.00 without further notice or set-off, upon execution of this Agreement and annually thereafter within ten days of the anniversary of the date of this Agreement to reimburse Licensor for the reasonable wear and tear on the property by Licensee's buses. Refunds of any pro-rated portion of the license fee shall be returned to METRO upon completion of the restoration of the property upon termination of the License Agreement pursuant to Paragraph 2, Term and Termination.

7. **Liability and Duty to Remediate and Insurance.** Licensee shall be liable for any and all damages, harm, losses, expenses or injuries to Licensor's Real Property (Felton Faire) (including its improvements), caused by Licensee's installation, maintenance and use of the Project, regardless of whether such damages were caused by accident, mistake, negligence, or intentional conduct. Notwithstanding the foregoing, Licensee shall not be responsible under this paragraph for any damages that would be considered to be within the scope of reasonable wear and tear. Licensee shall at its sole expense promptly repair or remediate any such damages. Licensee, at licensee's sole expense, shall obtain and keep in force during the term of this Agreement a policy of general liability insurance insuring Licensee and Licensor (and if requested by Licensor, Licensor's lender and property manager). Such insurance shall be in the amount of not less than three million dollars (\$3,000,000) per occurrence with METRO's SRI at \$250,000. **The limit of such insurance, shall not, however, limit the liability of Licensee hereunder.** Licensee shall deliver to Licensor, within five days after the execution of this Agreement and prior to commencement of any work on the Project, a certificate of insurance on the aforesaid general liability policy and documentation of SRI naming as additional insureds, Robert Marin and Celeste deSchlthess Marin, Trustees of the Marin Family Trust dba Felton Fair Shopping Center aka The Robert Marin and Celeste deSchulthess Marin Family Trust dba Felton Fair Shopping Center. The provisions of this Paragraph 7 shall survive termination of this Agreement except that upon the termination of the Agreement, METRO will not be required to continue to insure the Property as required herein.

8. **Indemnity.** Licensee shall to the fullest extent permitted by law, indemnify and hold harmless Licensor, together with Licensor's employees, agents, successors and assigns from and against any and all claims, causes of action, demands, losses,

judgments, fines, penalties, obligations, liens, and liabilities (including, without limitation, all expenses, actual attorneys' fees, and costs incurred in investigating or defending against the same) that are asserted against Licensor (collectively, "Costs") relating to or arising as a result of Licensee's activities and/or use of any kind on the Property, including the activities of Licensee's contractor(s), or their respective agents and employees.. The provisions of this Paragraph 8 shall survive termination of this Agreement.

9. **Adverse Litigation Rights.** Licensee has full and sole discretion to control all legal proceedings enumerated in Paragraph 8 asserted against Licensor, provided that Licensee at all times diligently pursues any such proceedings to conclusion. This discretion includes selecting counsel of Licensee's choice, selecting mediators, approving settlements, and all related choices associated with legal proceedings. The provisions of this Paragraph 9 shall survive termination of this Agreement.
10. **Liens and Claims.** Licensee shall keep the Property free and clear of mechanics' liens, or other similar liens for labor, service, supplies, equipment or material furnished in connection with the Project or Licensee's exercise of rights or fulfillment of obligations under this Agreement. Licensee shall fully and promptly pay and discharge and protect and hold harmless Licensor against any and all demands or claims which may ripen into such liens, and if any such lien is filed, Licensee shall have any such lien released at Licensee's sole expense. The provisions of this Paragraph 9 shall survive termination of this Agreement.
11. **Reimbursement for Expenses and Attorney Fees.** Licensee shall bear its own costs incurred in the preparation and negotiation of this Agreement and Licensee shall pay to Licensor the amount of five hundred dollars (\$500.00). Licensee shall also reimburse Licensor for all reasonable costs incurred by Licensor as a result of Licensee's failure to comply with this Agreement. However, in the event any party shall commence legal proceedings against another party for the purpose of enforcing any provision of this Agreement, or by reason of any breach arising under the provisions hereof, then the prevailing party or parties in such proceedings shall be entitled to reasonable litigation expenses, including attorneys' fees and expert fees, to be determined by the Court.
12. **Assignment, Successor and Assigns.** Licensee may not assign any of its rights under this Agreement, either voluntarily or by operation of law, without Licensor's prior written consent, which shall not be unreasonably withheld. No assignment by Licensee shall release such assignor from any liability under this License Agreement. Subject to the foregoing, this Agreement shall be binding upon and inure to the benefit of the parties hereto and their respective heirs, personal representatives, successors and assigns, including without limitation subsequent owners of the Property.

13. **Execution of Agreement.** Each signatory hereto warrants to the other parties hereto its authority to sign on behalf of the party for whom he or she purports to sign.
14. **Entire Agreement.** This Agreement sets forth the entire agreement of the parties with respect to the subject matter hereof and supersedes all prior discussions, negotiations, understandings or agreements relating thereto.
15. **Time is of the essence.** Time is of the essence in this Agreement.
16. **No Oral Modification.** No alteration or variation of this Agreement shall be valid or binding unless made in writing and signed by the parties hereto.
17. **Governing Law.** This Agreement shall be construed in accordance with and governed by the laws of the State of California.
18. **Venue.** Licensor and Licensee hereby stipulate that the proper venue in which any legal proceeding arising between the parties shall be heard is in Santa Cruz County, California Superior Court.
19. **Notices.** Any notices required or permitted to be given hereunder shall be given in writing and shall be delivered (a) in person or (b) by a commercial overnight courier that guarantees next day delivery and provides a receipt, and such notices shall be addressed as follows:

To Licensee:

Santa Cruz Metropolitan Transit District

Leslie R. White

General Manager

Santa Cruz Metropolitan Transit District

370 Encinal St., Suite 100

Santa Cruz, CA 95060-2101

To Licensor:

Robert Marin

12728 Parkyns Street

Los Angeles, CA 90049

20. **Counterparts; Facsimile Signatures.** This Agreement may be executed in one or more counterparts and delivered by facsimile transmission with original signatures to follow, each of which shall be deemed an original, but all of which together shall constitute but one and the same instrument.

21. **Property Rights.** The right granted in Paragraph 1 of this Agreement is a mere license only, and does not constitute an easement, right of way, or real property interest in the Property. No legal title or interest in Licensor's Property is otherwise created or vested in Licensee under this Agreement.
22. **No Third Party Beneficiaries.** This Agreement is solely for the benefit of Licensor and Licensee. Nothing contained in this Agreement shall be deemed to confer on anyone other than Licensor and Licensee the right to enforce the performance of or compliance with of any of the obligations contained herein.
23. **Partial Invalidity.** If any provision of this Agreement is held by a court of competent jurisdiction to be invalid or unenforceable, the remainder of the Agreement shall continue in full force and effect, and the parties agree to substitute for the invalid or unenforceable provision a valid and enforceable provision that most closely approximates the intent and economic effect of the invalid or unenforceable provision.
24. **Commencement Date.** This license shall be effective commencing December 19, 2008.
25. **Recording.** This License shall be recorded.
26. **Rule of Construction.** Licensor and Licensee shall both be deemed to have drafted this Agreement, and the rule of construction that a document is to be construed against the drafting party shall not be employed in the construction or interpretation of this Agreement.

This license is executed on December ____, 2008 by and between:

LICENSEE:

Leslie R. White, General Manager

LICENSOR/TRUSTEES:

Robert Marin

Celeste De Schulthess Marin

ADDENDUM TO LICENSE AND INDEMNITY AGREEMENT

In consideration of the execution of the License and Indemnity Agreement re Felton Faire between the Santa Cruz Metropolitan Transit District (hereinafter METRO Licensee) and Robert Marin and Celeste De Schulthess Marin, Trustees, METRO Licensee agrees not to file any objection to a County of Santa Cruz permit request made by Robert Marin and Celeste De Schulthess Marin, Trustees, or their successors, to enhance the Felton Faire Shopping Center unless the proposal would directly interfere with METRO's bus service to and/or through the site. METRO Licensee will be bound by this agreement as long as the license agreement is in effect.

LICENSEE:

Leslie R. White, General Manager

LICENSOR/TRUSTEES:

Robert Marin

Celeste De Schulthess Marin

10-28-08

Felton Fair Shopping Mall

Attachment A-1

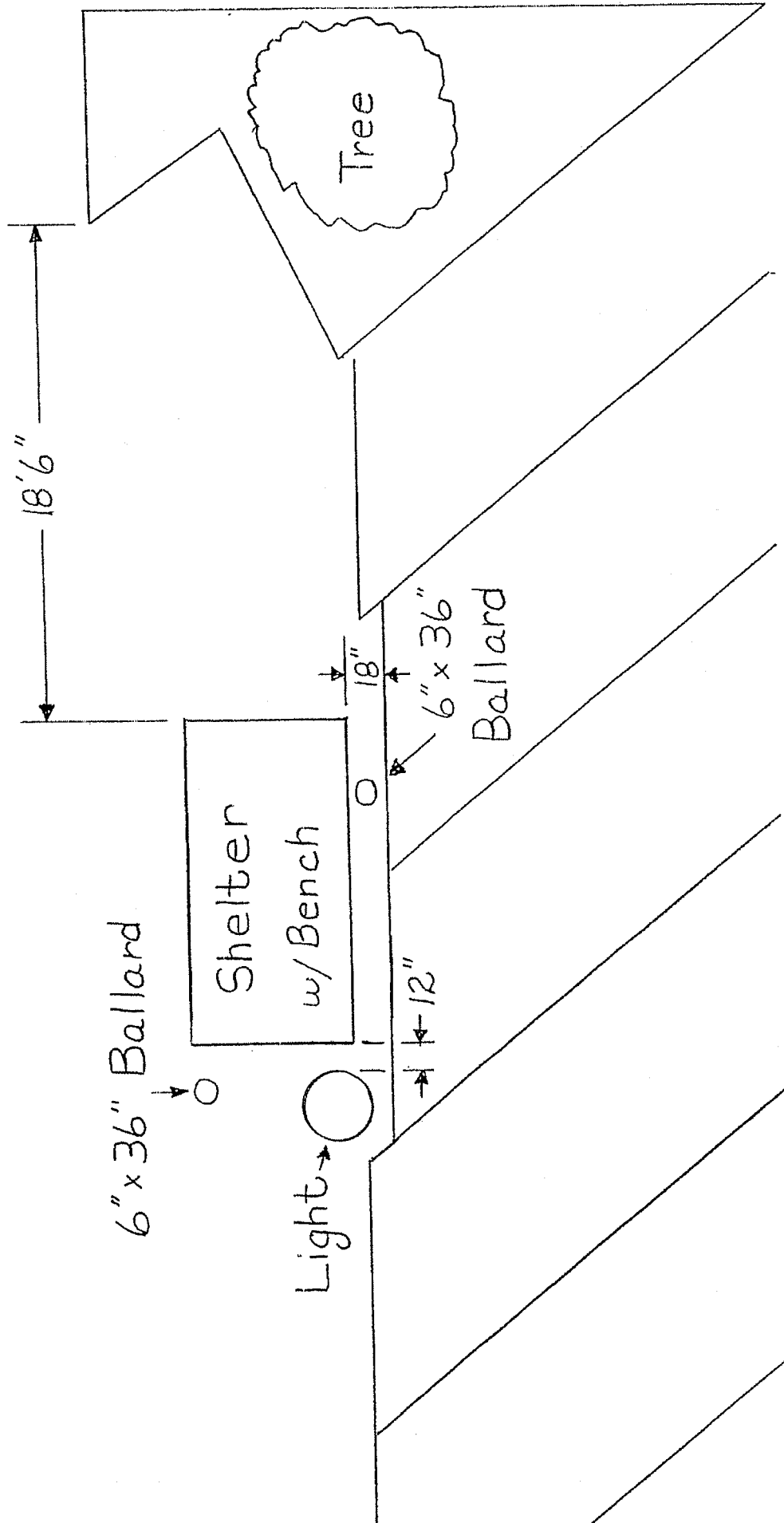



12.98

Attachment A-2

Santa Cruz Metropolitan Transit

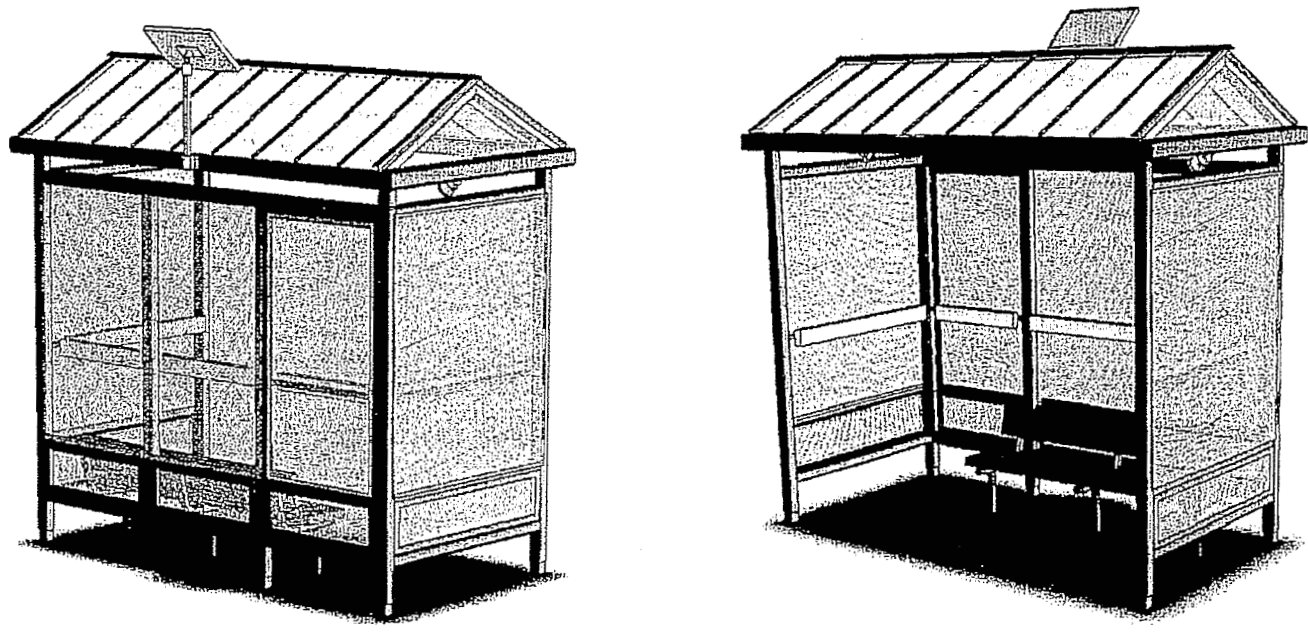
5'x10' Peak Roof Shelter



5-10-2007

12.29

DESIGNERS & BUILDERS OF SIGNS
SINCE 1953



2007 LNI CUSTOM MANUFACTURING INC.
12536 CHADRON AVE., HAWTHORNE, CA 90250
PHONE: 310.978.2000 FACSIMILE: 310.978.4000
HTTP://WWW.LNISIGNS.COM

Attachment A-3

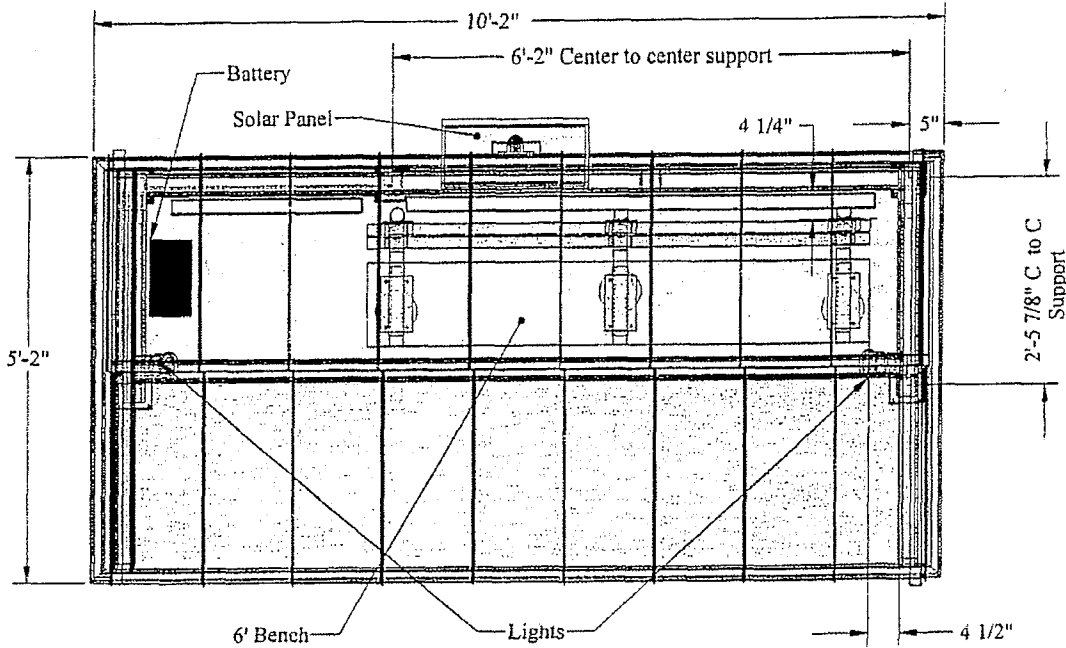

Shelter Layout Plan
Scale: 3/4"=1'



CONTENTS

Shelter Layout Plan	PG 2
Shelter Front, Right side View	PG 3
Shelter Assembly View	PG 4

12.9.10

PROJECT NAME: Santa Cruz Shelter	DRAWING:	APPROVAL	DATE	 <p>12345 California Street San Francisco, CA 94115 Phone: 415.555.1234 www.lmi.com</p> <p>DESIGNERS AND BUILDERS OF BENCHES</p>	<table border="1"> <thead> <tr> <th>DATE</th> <th>BY</th> <th>DESCRIPTION</th> </tr> </thead> <tbody> <tr> <td>R1</td> <td>5 10 07</td> <td>FJ</td> <td>Kick panel cabinet & solar panel</td> </tr> <tr> <td>R2</td> <td></td> <td></td> <td></td> </tr> <tr> <td>R3</td> <td></td> <td></td> <td></td> </tr> <tr> <td>R4</td> <td></td> <td></td> <td></td> </tr> <tr> <td>R5</td> <td></td> <td></td> <td></td> </tr> </tbody> </table>	DATE	BY	DESCRIPTION	R1	5 10 07	FJ	Kick panel cabinet & solar panel	R2				R3				R4				R5				<p>NOTE: THIS IS AN APPROVAL DRAWING CREATED BY LMI. CUSTOMER HAS TO BE ELIGIBLE FOR YOUR PERSONAL USE IN CONNECTION WITH A PROJECT. THESE DRAWINGS ARE FOR INFORMATION ONLY. THE USER IS RESPONSIBLE FOR OBTAINING ALL NECESSARY PERMITS AND APPROVALS FROM LOCAL AUTHORITIES. LMI IS NOT RESPONSIBLE FOR ANY DAMAGE OR INJURY CAUSED BY THE USER'S MISUSE OF THESE DRAWINGS.</p> <p>GENERAL NOTES</p> <p>CUSTOMER TO PROVIDE NECESSARY ELECTRICAL SERVICE AND WIRING TO BE INSTALLED BY THE USER. ALL ELECTRICAL WORK MUST BE DONE IN ACCORDANCE WITH ALL APPLICABLE ELECTRICAL CODES AND ALL LOCAL, STATE AND FEDERAL REGULATIONS. MATERIALS AND METHODS OF CONSTRUCTION SHALL BE AS APPROVED BY THE USER.</p>	<p>SHEET</p> <p>2 of 4</p>
DATE	BY	DESCRIPTION																												
R1	5 10 07	FJ	Kick panel cabinet & solar panel																											
R2																														
R3																														
R4																														
R5																														
ADDRESS: Various	SCALE: AS SHOWN	CLIENT:																												
CITY/STATE: various	DRAWN BY: F. Infante	SALES:																												
TELEPHONE: n/a	DESIGN DATE: Jan*30*07	LANDLORD:																												
FAX NUMBER: n/a	SALES PERSON: Theresa Roth	PROGRAMMING:																												
		ENGINEER:																												

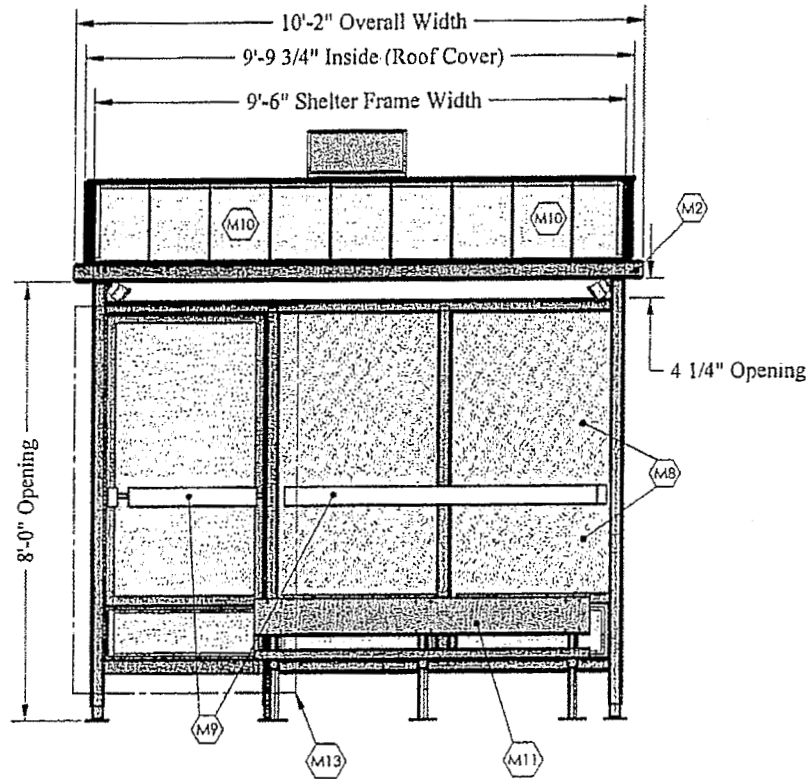

1 Shelter Front View
Scale: 1/2"-1'

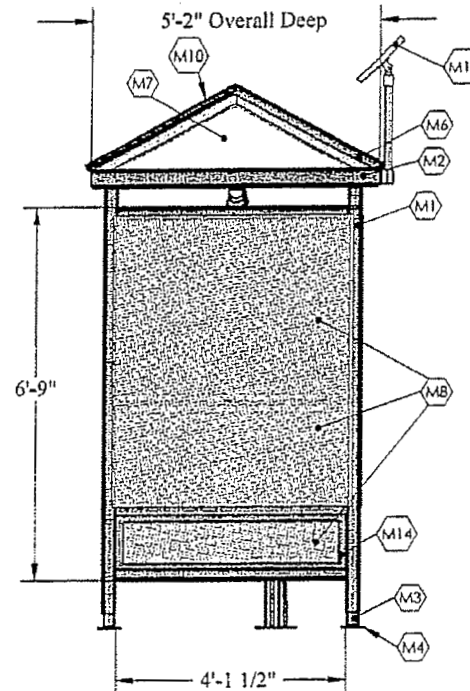

2 Shelter Right Side View
Scale: 1/2"-1'



Finish/Paint/Powder Coat	
(P1)	Cardinal P004-BR23 bronze 40% gloss

Materials / Substrate	
(M1)	3"x3"x3/16" Thick Aluminum Square Tube
(M2)	2"x4"x1/8" Thick Aluminum Rectangular Tube
(M3)	2 1/2"x2 1/2" x 1/4" Thick Alum. Square Tube (Sleeve)
(M4)	5"x5"x3/8" Thick Alum. Plate
(M5)	2"x4"x1/4" Thick Aluminum "C" Channel
(M6)	1"x2"x1/8" Thick Aluminum Rectangular Tube (Roof Rafter)
(M7)	1/4" Clear Plexiglass
(M8)	1/8" Perforated Aluminum Panel
(M9)	2"x4"x1/8" Aluminum Rectangular Tube (Hand rail)
(M10)	Aluminum .063 Roof Panels
(M11)	6" Bench
(M12)	Solar Panel
(M13)	Removable Panel Assembly for Optional Egress
(M14)	1 1/2"x 1/8" aluminum angle

12.011

PROJECT NAME:	DRAWING:	APPROVAL	DATE	DATE	BY	DESCRIPTION	REVISIONS	GENERAL NOTES	SHEET
Santa Cruz Shelter	SCALE: AS SHOWN	CLIENT		R1	5 10 07	FJ	Kick panel cutout & solar panel	NOTE: THIS IS AN ORIGINAL UNPUBLISHED DRAWING CREATED BY LNI CONSULTING, INC. IT IS LEGALIZED FOR PUBLIC RECORD USE BY CONSTRUCTION PROJECTS. PLEASE CONTACT LNI CONSULTING, INC. IF YOU HAVE ANY QUESTIONS REGARDING THIS DRAWING. IT IS NOT TO BE USED FOR ANY OTHER PURPOSES WITHOUT THE WRITTEN PERMISSION OF LNI CONSULTING, INC.	3 OF 4
ADDRESS: Various	DRAWN BY: F. Infante	SALES		R2					
CITY/STATE: various	DESIGN DATE: Jan *30*07	LANDLORD		R3					
TELEPHONE: n/a	SALES PERSON: Theresa Roth	PROGRAMMING		R4					
FAX NUMBER: n/a		ENGINEER		R5					



DESIGNERS AND BUILDERS OF SHELTERS

12.a.12

PROJECT NAME: Santa Cruz Shelter		DRAWING:		SALES PERSON:		FAX NUMBER: n/a	
ADDRESS: Various		SCALE: AS SHOWN		CLIENT:		CITY/STATE: Various	
DRAWN BY: F. WILKIE		LANDGRD:		PROGRAMME:		TELEPHONE: n/a	
DESIGN DATE: Jan*30*07		ENGINEER:		DESIGNER AND BUILDERS OF RECORD:		DESIGN DATE: Jan*30*07	
DATE:		DATE:		DATE:		DATE:	
APPROVAL:		DATE:		DATE:		DATE:	
BY:		DATE:		DATE:		DATE:	
DESCRIPTION:		DATE:		DATE:		DATE:	
R1		S 10 07		FJ		Kick panel cabinet & solid panel	
R2							
R3							
R4							
R5							
GENERAL NOTES:							
1. THIS DRAWING IS THE PROPERTY OF L&L ARCHITECTS AND ENGINEERS. IT IS TO BE USED ONLY FOR THE PROJECT AND SITE SPECIFICALLY IDENTIFIED HEREON. IT IS NOT TO BE REPRODUCED, COPIED, OR TRANSMITTED IN ANY FORM OR BY ANY MEANS, ELECTRONIC OR MECHANICAL, INCLUDING PHOTOCOPYING, RECORDING, OR BY ANY INFORMATION STORAGE AND RETRIEVAL SYSTEM, WITHOUT THE WRITTEN PERMISSION OF L&L ARCHITECTS AND ENGINEERS.							
4 OF 4							
SHEET							

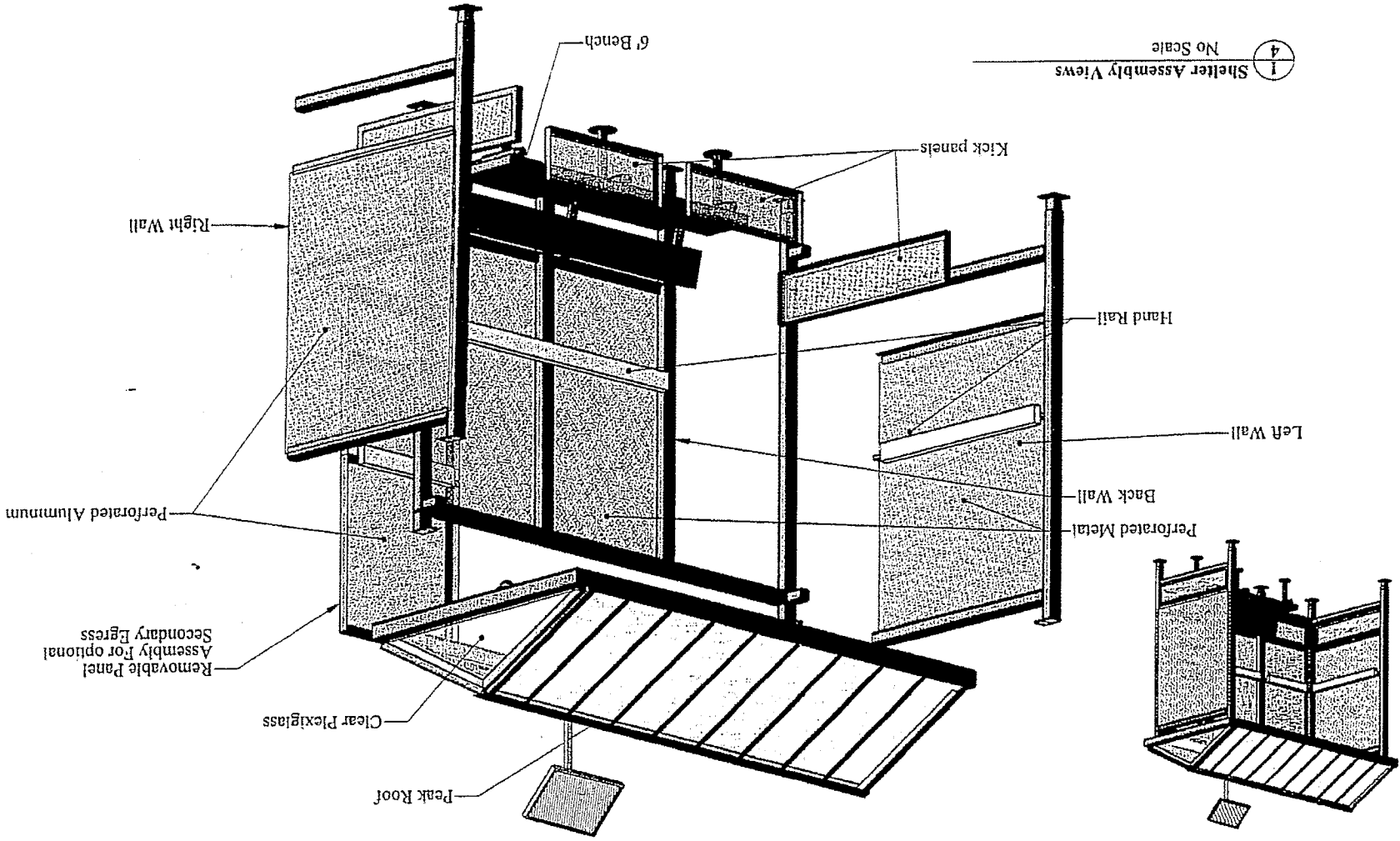

Attachment A-5

Attachment B-1

EXHIBIT A
TO THE NOVEMBER 14, 2008
LICENSE AND INDEMNITY
AGREEMENT BETWEEN ROBERT
AND CELESTE DESCHULFHESS
MARIN, TRUSTEES, AND
SANTA CRUZ METROPOLITAN
TRANSIT DISTRICT



FELTON FAIR SHOPPING
CENTER
FELTON, CA.

NOT TO SCALE

APPROXIMATE LOCATION OF
BUS STOP SHELTER X

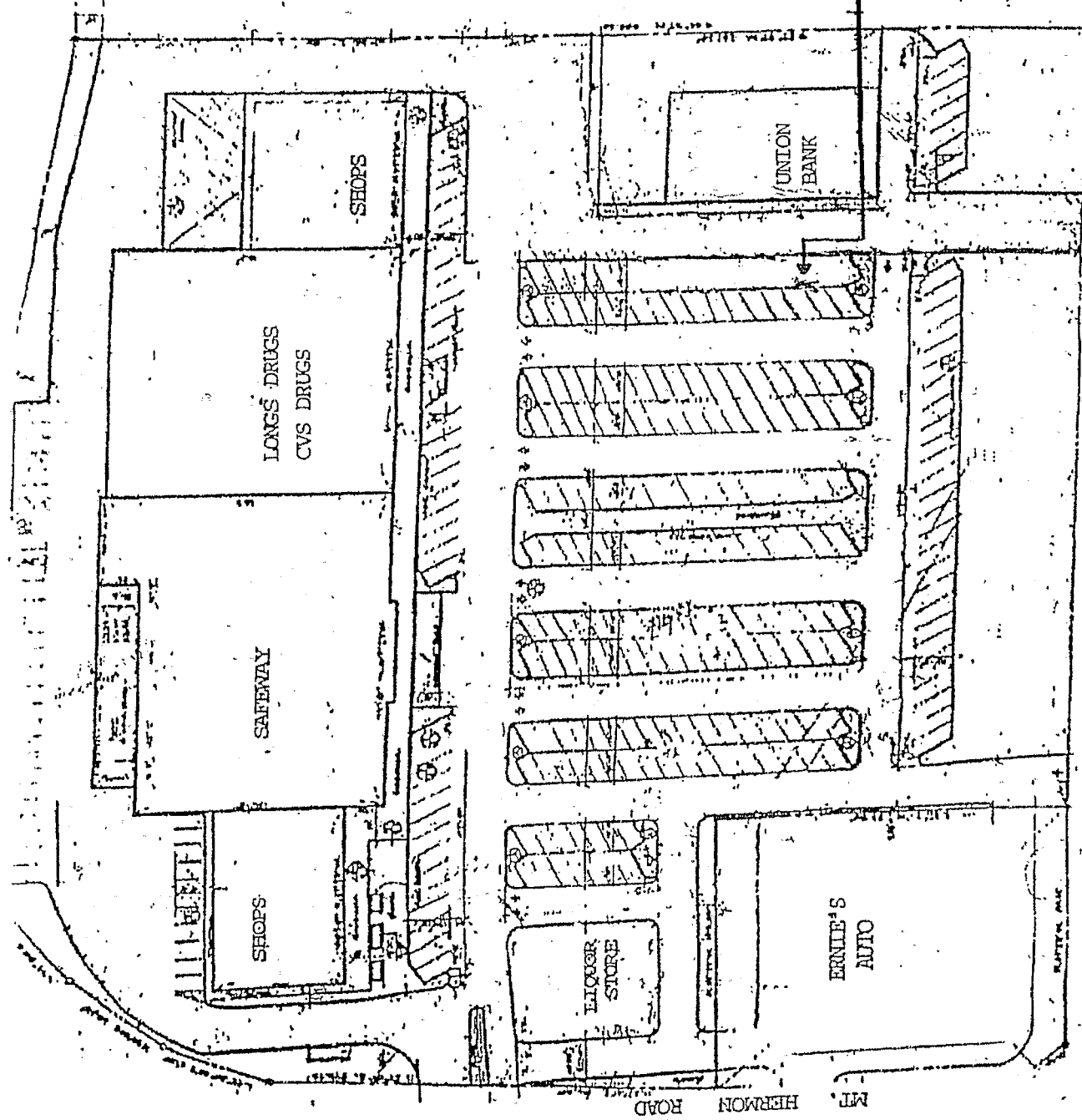

GRAHAM HILL ROAD

MT. HERMON ROAD

Attachment B-2

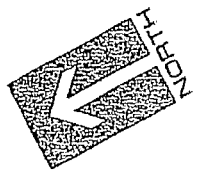
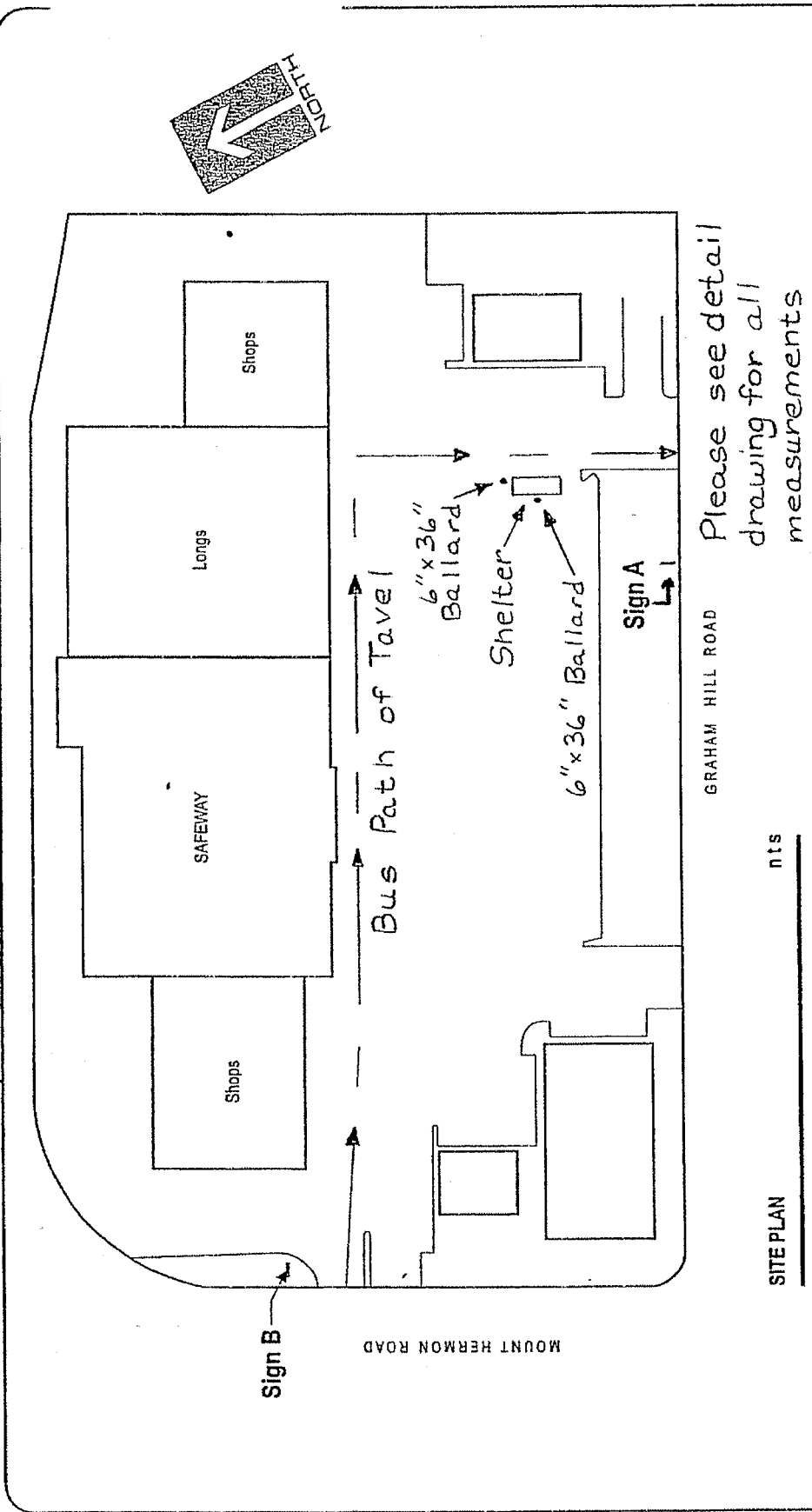

GRAHAM HILL ROAD
 Please see detail drawing for all measurements

nts

SITE PLAN

<p>120 Encinal Street Santa Cruz, CA 95060-2111 Phone: 831/469-8208 Fax: 831/469-8172 Email: mike@northwestsigns.com Web: www.northwestsigns.com</p>	<p>Project: Felton Fair Address: 8231 Graham Hill Road Felton, CA</p>	<p>Drawn By: K. Johnson Checked By: M. Johnson Date: 12-28-2008 Project Manager:</p>	<p>Drawn By: K. Johnson Checked By: M. Johnson Date: 12-28-2008 Project Manager:</p>
<p>120 Encinal Street Santa Cruz, CA 95060-2111 Phone: 831/469-8208 Fax: 831/469-8172 Email: mike@northwestsigns.com Web: www.northwestsigns.com</p>	<p>Project: Felton Fair Address: 8231 Graham Hill Road Felton, CA</p>	<p>Drawn By: K. Johnson Checked By: M. Johnson Date: 12-28-2008 Project Manager:</p>	<p>Drawn By: K. Johnson Checked By: M. Johnson Date: 12-28-2008 Project Manager:</p>



APN 071 331 02 831

12.a14